

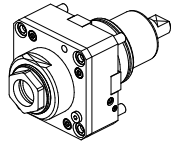

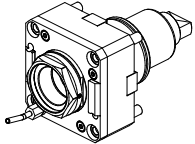

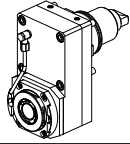
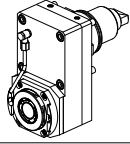
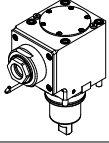
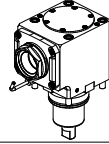
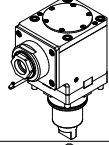
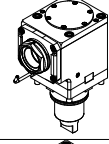
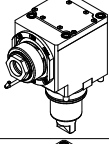
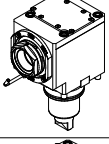
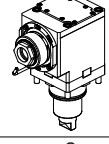
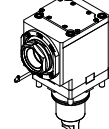
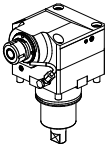

		PAGINA Page Seite
<p>MODULO MOTORIZZATO RADIALE Radial driven tool Radial angetriebenes Werkzeug</p>		DW0010.5.00
<p>MODULO MOTORIZZATO RADIALE MTSK Radial MTSK driven tool Radial MTSK angetriebenes Werkzeug</p>		DW0010.5.00.K
<p>MODULO MOTORIZZATO RADIALE DISASSATO IN Z 110mm Radial driven tool re-directed in Z by 110mm Radial angetriebenes Werkzeug achsversetzt in Z um 110mm</p>		DW0030.5.10
<p>MODULO MOTORIZZATO RADIALE RIDOTTO I=2:1 DISASSATO IN Z 110mm Radial geared-down I=2:1 driven tool re-directed in Z by 110mm Radial angetriebenes Werkzeug untersetzt I=2:1 achsversetzt in Z um 110mm</p>		DW0030.5.20
<p>MODULO MOTORIZZATO ASSIALE H=85mm Axial driven tool H=85mm Axial angetriebenes Werkzeug H=85mm</p>		DW0150.5.10
<p>MODULO MOTORIZZATO ASSIALE MTSK H=85mm Axial MTSK driven tool H=85mm Axial MTSK angetriebenes Werkzeug H=85mm</p>		DW0150.5.10.K
<p>MODULO MOTORIZZATO ASSIALE H=110mm Axial driven tool H=110mm Axial angetriebenes Werkzeug H=110mm</p>		DW0150.5.20
<p>MODULO MOTORIZZATO ASSIALE MTSK H=110mm Axial MTSK driven tool H=110mm Axial MTSK angetriebenes Werkzeug H=110mm</p>		DW0150.5.20.K
<p>MODULO MOTORIZZATO ASSIALE RIDOTTO I=2:1 H=85mm Axial geared-down I=2:1 driven tool H=85mm Axial angetriebenes Werkzeug untersetzt I=2:1 H=85mm</p>		DW0190.5.10
<p>MODULO MOTORIZZATO ASSIALE MTSK RIDOTTO I=2:1 H=85mm Axial MTSK geared-down I=2:1 driven tool H=85mm Axial MTSK angetriebenes Werkzeug untersetzt I=2:1 H=85mm</p>		DW0190.5.10.K
<p>MODULO MOTORIZZATO ASSIALE RIDOTTO I=2:1 H=110mm Axial geared-down I=2:1 driven tool H=110mm Axial angetriebenes Werkzeug untersetzt I=2:1 H=110mm</p>		DW0190.5.20
<p>MODULO MOTORIZZATO ASSIALE MTSK RIDOTTO I=2:1 H=110mm Axial MTSK geared-down I=2:1 driven tool H=110mm Axial MTSK angetriebenes Werkzeug untersetzt I=2:1 H=110mm</p>		DW0190.5.20.K

		PAGINA Page Seite
MODULO MOTORIZZATO ASSIALE MOLTIPLICATO I=1:3 Axial geared-up I=1:3 driven tool Axial angetriebenes Werkzeug uebersetzt I=1:3		DW 0205.5.10
MODULO MOTORIZZATO ORIENTABILE +/-90° +/-90° adjustable angle driven tool Angetriebenes Werkzeug schwenkbar +/-90°		DW 0339.5.00
MODULO MOTORIZZATO PORTACREATORE MAGGIORATO Reinforced driven gear hobber Angetriebenes Zahnradwaelzfraes-Werkzeug vergroessert		DW 0340.5.60
MODULO MOTORIZZATO PORTACREATORE (TAGLIA GRANDE) Driven gear hobber (big size) Angetriebenes Zahnradwaelzfraes-Werkzeug (grosse version)		DW 0340.5.80
INTERFACCIA PER MODULI BMT-65 H=33mm BMT-65 tooling adapter cartridge H=33mm Adapter-Patrone fuer BMT-65 werkzeuge H=33mm		DW 0385.5.00
PORTAUTENSILE RADIALE SINGOLO QD=32mm / QD=1 1/4" Radial single static tool QD=32mm / QD=1 1/4" Radial Single-Werkzeughalter QD=32mm / QD=1 1/4"		DW 0423.5.00
PORTAUTENSILE ASSIALE SINGOLO QD=32mm / QD=1 1/4" Axial single static tool QD=32mm / QD=1 1/4" Axial Single-Werkzeughalter QD=32mm / QD=1 1/4"		DW 0552.5.00
PORTAUTENSILE ASSIALE PER BARENO Ø80mm / Ø3" H=85mm Axial single boring bar holder Ø80mm / Ø3" H=85mm Axial Bohrhalter Ø80mm / Ø3" H=85mm		DW 0580.5.20

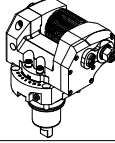
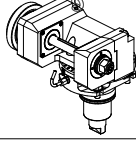
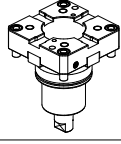
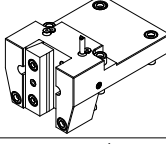
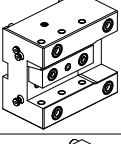
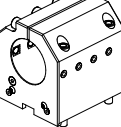
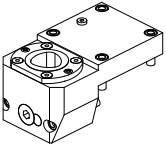
PORTAUTENSILE RADIALE SINGOLO ARRETRATO MT CAPTO Radial single rear-set static tool MT CAPTO Radial Single-Werkzeughalter zurueckversetzt MT CAPTO		DW 0430.E.60 
PORTAUTENSILE ASSIALE SINGOLO MT CAPTO Axial single static tool MT CAPTO Axial Single-Werkzeughalter MT CAPTO		DW 0550.E.60 

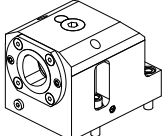

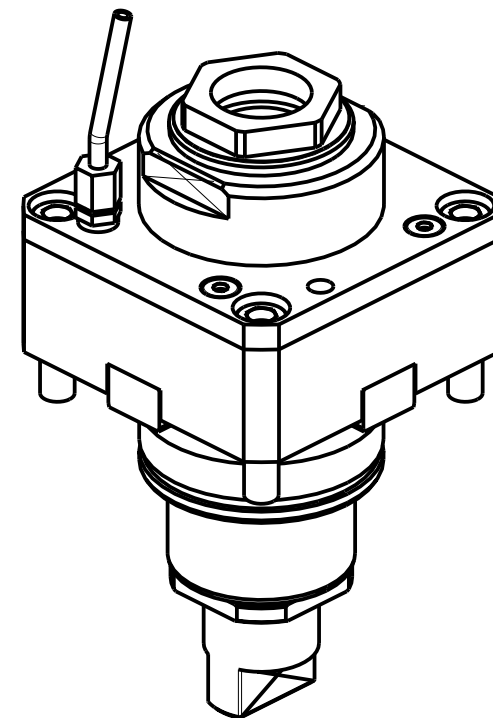
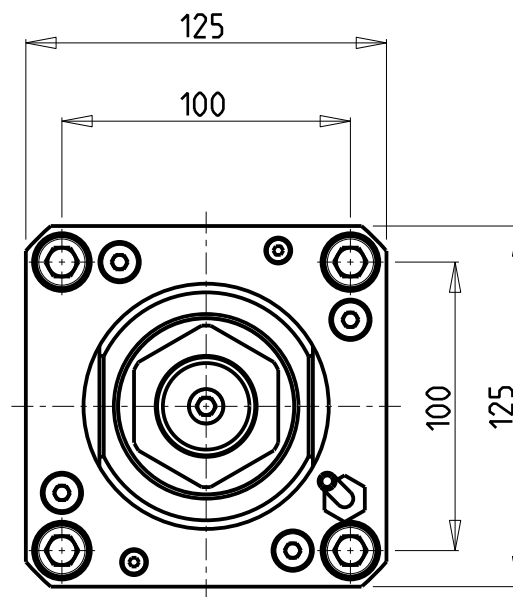
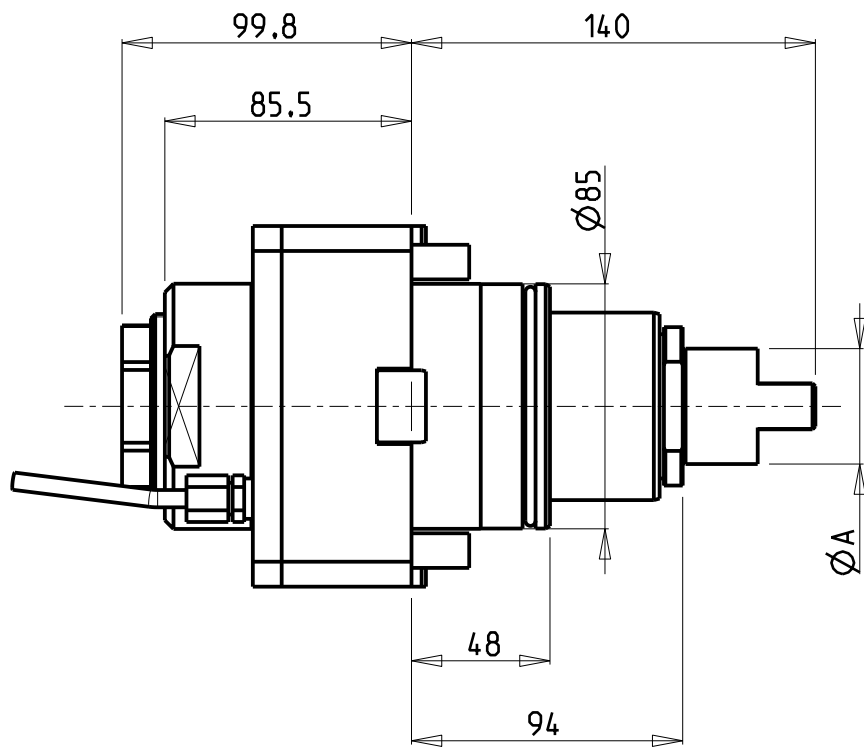
Cod. MT	Mandrino Spindle Spindel	I	RPM	Coppia Max Max Torque Max Drehmoment	Lubrificazione int. Coolant through Innenkuehlung	Lubrificazione est. Ext. coolant Aussenkuehlung	A	CHIAVI NON INCLUSE Keys not included Schluessel nicht einbegriffen	
DW01240150	ER A 50	1:1	3000	210Nm	-	X	40	CHUB50	CHUB74
DW00160250	ER A 50	1:1	3000	210Nm	P=30bar	X	28	CHUB50	CHUB74

DOOSAN BMT 85

MOD: VT900M/TM - VT1100M - PUMA 600M/LM - PUMA 700M/LM - PUMA 800M/LM

MODULO MOTORIZZATO RADIALE

Radial driven tool

Radial angetriebenes Werkzeug

Subject to change without notice.

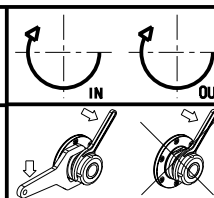

M.T. srl

Via Casino Albini 480
Tel. 0541/956034-957884
Fax 0541/956341

47842 S. GIOVANNI IN M. (RN)
e-mail: mtma@mtmarchetti.com
http://www.mtmarchetti.com

PRODUZIONE MODULI ROTANTI



PAGINA DW0010-5-00

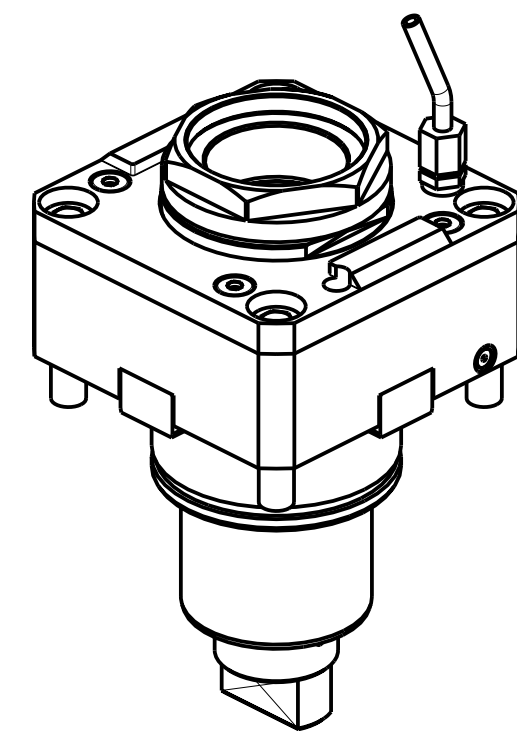
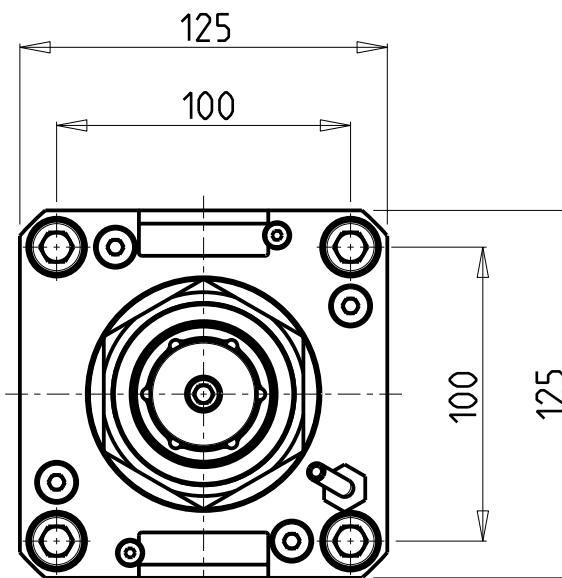
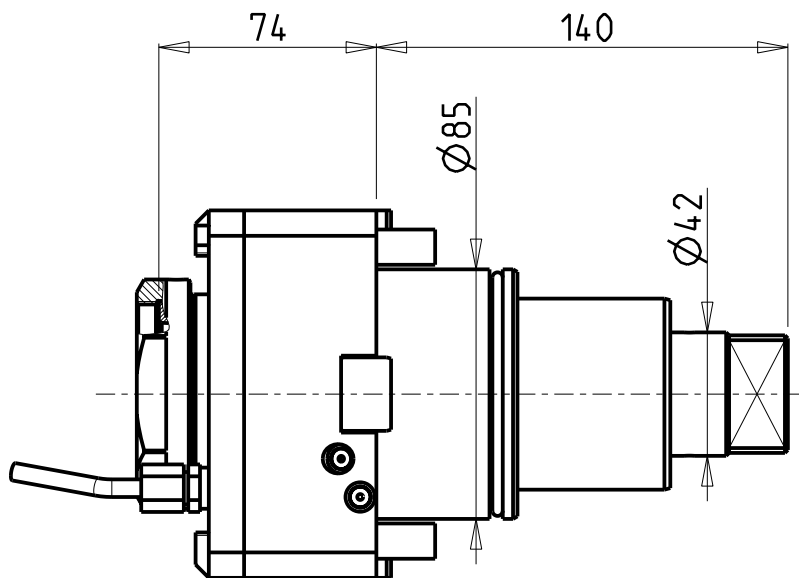

PER PORTAUTENSILI MODULARI MTSK-63 VEDI PAG. TBL300-1-63
 FOR MTSK-63 QUICK CHANGE TOOLHOLDERS CLAMPINGS SEE PAGE TBL300-1-63
 FUER MTSK-63 MODULARE WERKZEUGAUFNAHMEN SIEHE SEITE TBL300-1-63

Cod. MT	Mandrino Spindle Spindel	I	RPM	Coppia Max Max Torque Max Drehmoment	Lubrificazione int. Coolant through Innenkuehlung	Lubrificazione est. Ext. coolant Aussenkuehlung	CHIAVI NON INCLUSE Keys not included Schluessel nicht einbegriffen	
DW01750163	MTSK-63	1:1	3000	210Nm	-	X	CHUB68	NZL0010023 •
DW01750263	MTSK-63	1:1	3000	210Nm	P=30bar	X	CHUB68	NZL0010023 •

- Chiave inclusa
- Key included
- Schluessel inbegriffen

DOOSAN BMT 85
 MOD: VT900M/TM - VT1100M - PUMA 600M/LM - PUMA 700M/LM - PUMA 800M/LM

MODULO MOTORIZZATO RADIALE MTSK
 Radial MTSK driven tool
 Radial MTSK angetriebenes Werkzeug

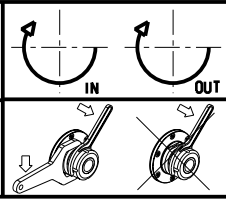

M.T. srl
 Via Casino Albini 480
 Tel. 0541/956034-957884
 Fax 0541/956341
 47842 S. GIOVANNI IN M. (RN)
 e-mail: mtma@mtmarchetti.com
 http://www.mtmarchetti.com

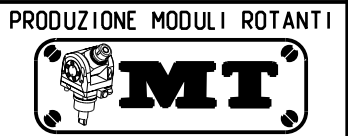

PAGINA DW0010-5-00-K

Subject to change without notice.

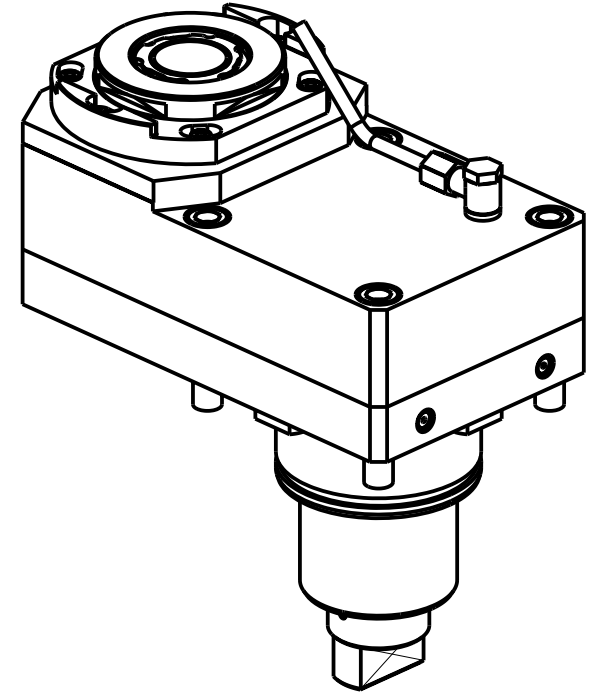
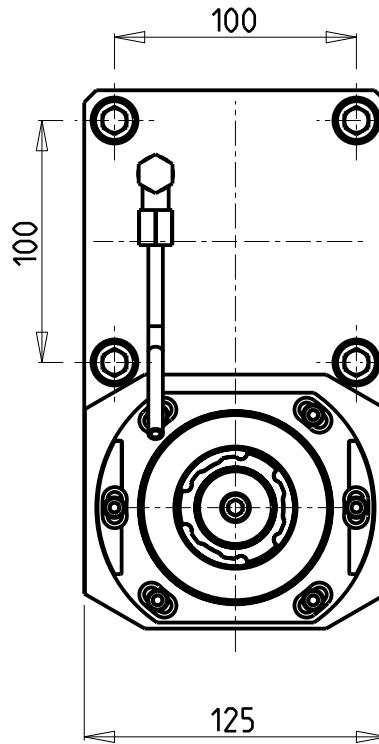
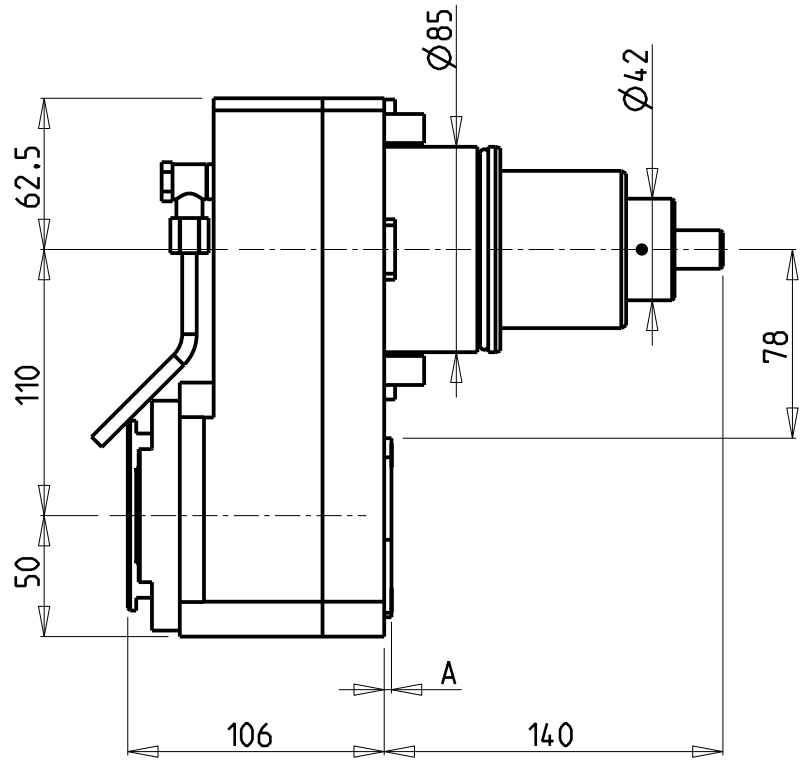

Cod. MT	Mandrino Spindle Spindel	I	RPM	Coppia Max Max Torque Max Drehmoment	Lubr.interna Coolant through Innenkuehlung	Lubr. esterna Ext. coolant Aussenkuehlung	A	CHIAVI NON INCLUSE Keys not included Schluessel nicht einbegriffen		
								CHUB36	NZL0010023	CHTAER40ZC
DW02121140	ERA40	1:1	3000	180Nm	-	X	3	CHUB36	NZL0010023	CHTAER40ZC
DW02121240	ERA40	1:1	3000	180Nm	P=70bar	X	14	CHUB36	NZL0010023	CHTAER40ZC

- Chiave inclusa
- Key included
- Schluessel inbegriffen

DOOSAN BMT 85

MOD: VT900M/TM - VT1100M - PUMA 600M/LM - PUMA 700M/LM - PUMA 800M/LM

MODULO MOTORIZZATO RADIALE DISASSATO IN Z 110mm

Radial driven tool re-directed in Z by 110mm

Radial angetriebenes Werkzeug achsversetzt in Z um 110mm

Subject to change without notice.

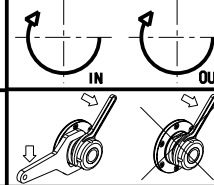

M.T. srl

Via Casino Albini 480
Tel. 0541/956034-957884

Fax 0541/956341

47842 S. GIOVANNI IN M. (RN)

e-mail: mtma@mtmarchetti.com

http://www.mtmarchetti.com

PRODUZIONE MODULI ROTANTI



PAGINA DW0030-5-10

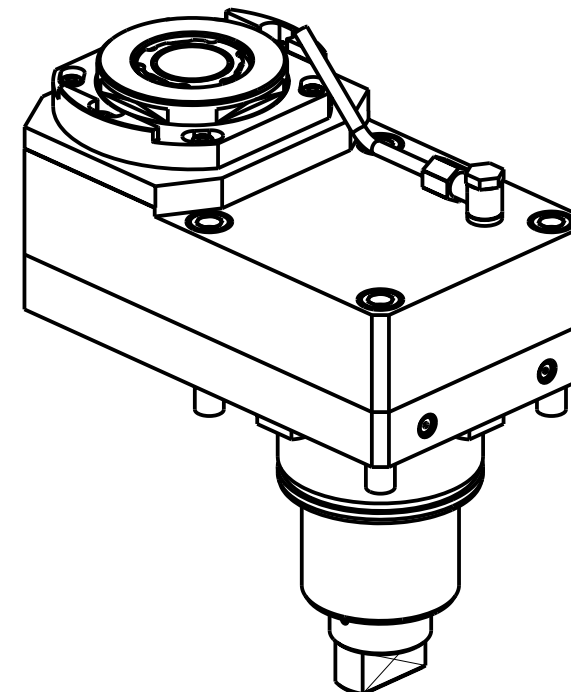
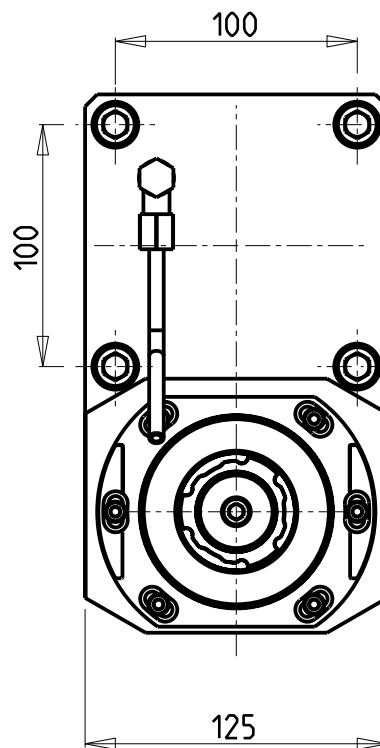
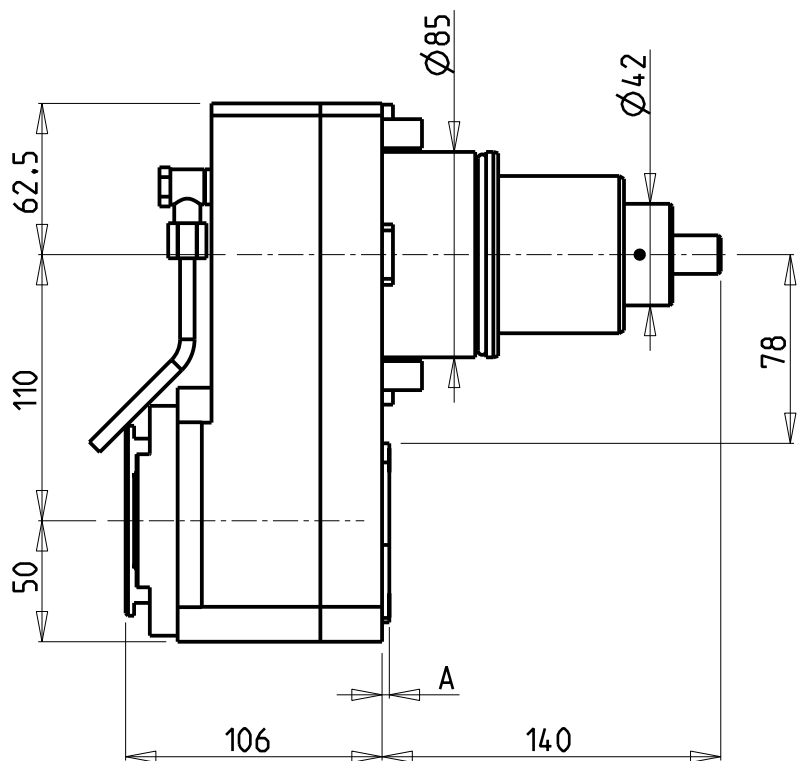

Cod. MT	Mandrino Spindle Spindel	I	RPM	Coppia Max Max Torque Max Drehmoment	Lubr.interna Coolant through Innenkuehlung	Lubr. esterna Ext. coolant Ausseinkuehlung	A	CHIAVI NON INCLUDE Keys not included Schluessel nicht einbegriffen		
DW 02122140	ERA40	2:1	1500	270Nm	-	X	3	CHUB36	NZL0010023	CHTAER40ZC
DW 02122240	ERA40	2:1	1500	270Nm	P=70bar	X	14	CHUB36	NZL0010023	CHTAER40ZC

- Chiave inclusa
- Key included
- Schluessel inbegriffen

DOOSAN BMT 85

MOD: VT900M/TM - VT1100M - PUMA 600M/LM - PUMA 700M/LM - PUMA 800M/LM

MODULO MOTORIZZATO RADIALE RIDOTTO I=2:1 DISASSATO IN Z 110mm

Radial geared-down I=2:1 driven tool re-directed in Z by 110mm

Radial angetriebenes Werkzeug untersetzt I=2:1 achsversetzt in Z um 110mm

Subject to change without notice.

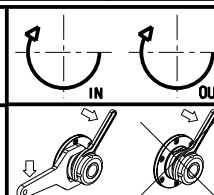

M.T. srl
Via Casino Albini 480
Tel. 0541/956034-957884
Fax 0541/956341
47842 S. GIOVANNI IN M. (RN)
e-mail: mtma@mtmarchetti.com
http://www.mtmarchetti.com

PRODUZIONE MODULI ROTANTI



PAGINA DW0030-5-20

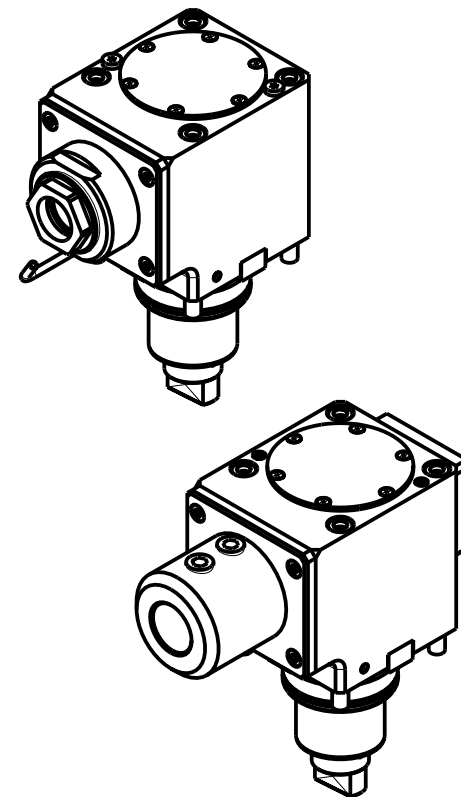
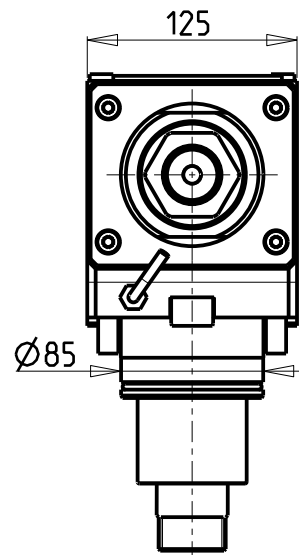
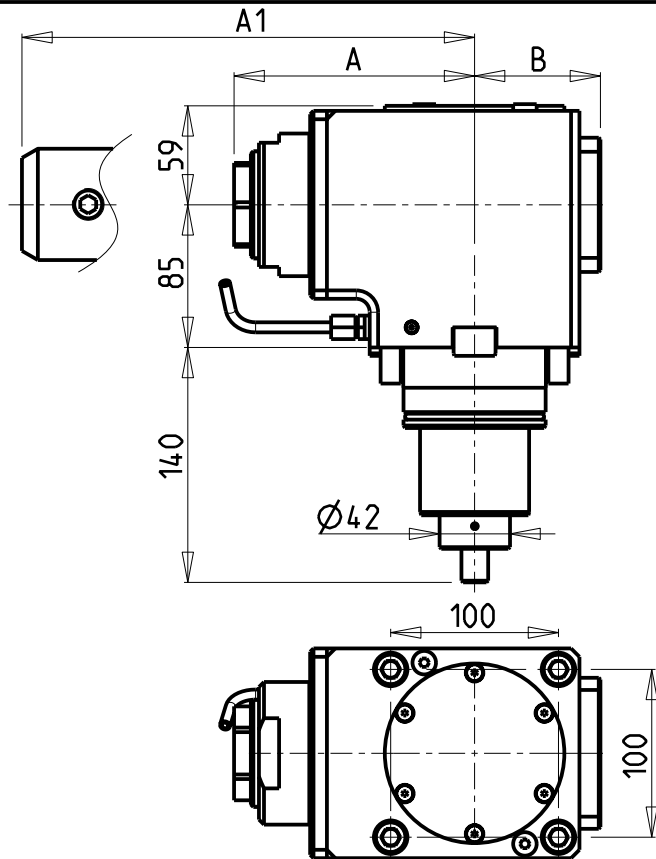

Cod. MT	Mandrino Spindle Spindel	I	RPM	Coppia Max Max Torque Max Drehmoment	Reversibile lato mandrino/contromandrino Reversible sub/main spindle side Umkehrbare Spindel-seite/ Gegenspindel-seite	Lubr.interna Coolant through Innenkuehlung	Lubr. esterna Ext. coolant Aussenkuehlung	A	A1	B	CHIAVI NON INCLUDE Keys not included Schluessel nicht einbegriffen	
DW00150150	ER A 50	1:1	3000	210Nm	X		X	143.33	-	75	CHUB50	CHUB74
DW00151250	ER A 50	1:1	3000	210Nm	X	P=70bar	X	143.33	-	86	CHUB50	CHUB74
DW00150240	Weldon 40	1:1	3000	210Nm	X		X	-	175.5	75	-	-
DW00150140	Weldon 40	1:1	3000	210Nm	X	P=70bar	X	-	175.5	86	-	-

DOOSAN BMT 85

MOD: VT900M/TM - PUMA 600M/LM - PUMA 700M/LM - PUMA 800M/LM

MODULO MOTORIZZATO ASSIALE H=85mm

Axial driven tool H=85mm

Axial angetriebenes Werkzeug H=85mm

Subject to change without notice.

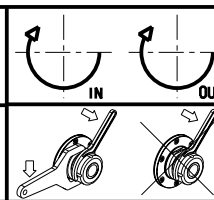

M.T. srl

Via Casino Albini 480
Tel. 0541/956034-957884

Fax 0541/956341

47842 S. GIOVANNI IN M. (RN)

e-mail: mtma@mtmarchetti.com

http://www.mtmarchetti.com

PRODUZIONE MODULI ROTANTI



PAGINA DW0150-5-10

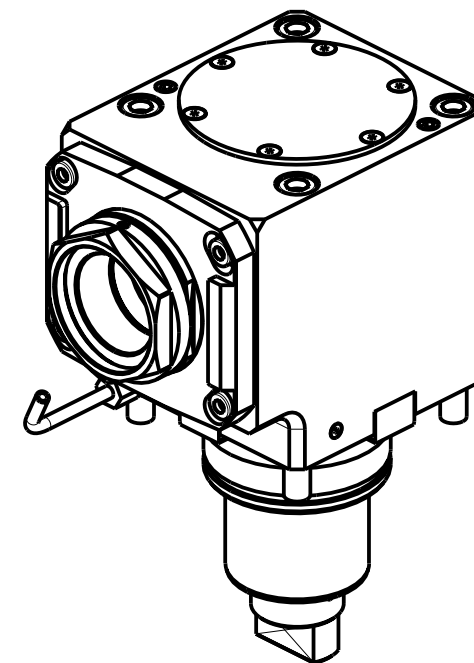
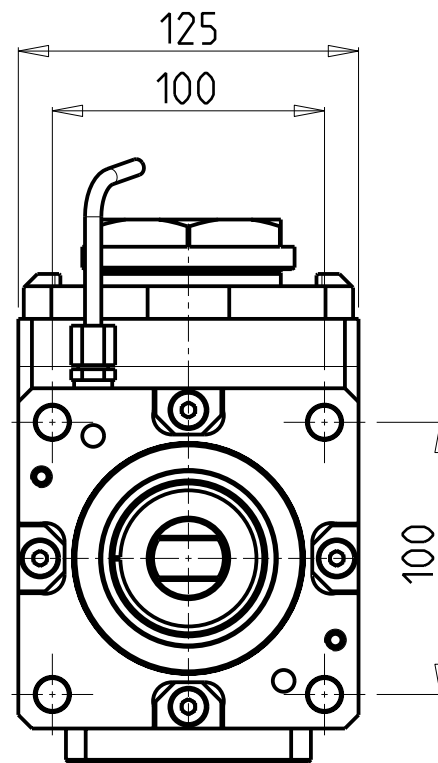
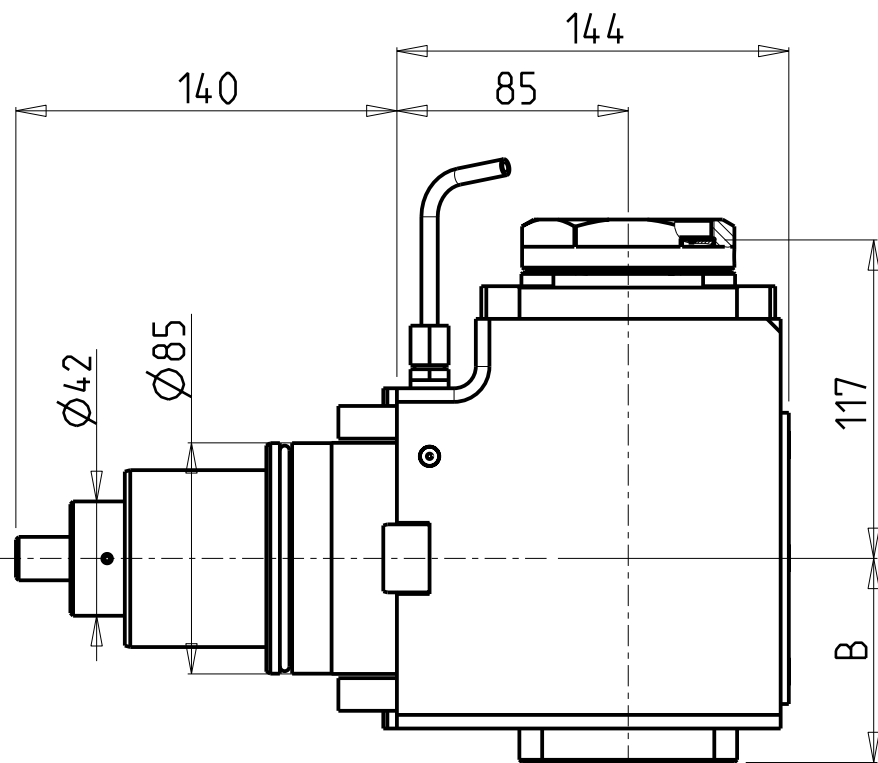

PER PORTAUTENSILI MODULARI MTSK-63 VEDI PAG. TBL300-1-63
 FOR MTSK-63 QUICK CHANGE TOOLHOLDERS CLAMPINGS SEE PAGE TBL300-1-63
 FUER MTSK-63 MODULARE WERKZEUGAUFNAHMEN SIEHE SEITE TBL300-1-63

Cod. MT	Mandrino Spindle Spindel	I	RPM	Coppia Max Max Torque Max Drehmoment	Reversibile lato mandrino/contromandrino Reversible sub/main spindle side Umkehrbare Spindel-seite/Gegenspindel-seite	Lubr.interna Coolant through Innenkuehlung	Lubr. esterna Ext. coolant Aussenkuehlung	B	CHIAVI NON INCLUDE Keys not included Schlüssel nicht einbegriffen	
DW01590163	MTSK-63	1:1	3000	210Nm	X	-	X	75	CHUB68	NZL0010023 ■
DW01590263	MTSK-63	1:1	3000	210Nm	X	P=70bar	X	86	CHUB68	NZL0010023 ■

- Chiave inclusa
- Key included
- Schlüssel inbegriffen

DOOSAN BMT 85

MOD: VT900M/TM - PUMA 600M/LM - PUMA 700M/LM - PUMA 800M/LM

MODULO MOTORIZZATO ASSIALE MTSK H=85mm

Axial MTSK driven tool H=85mm

Axial MTSK angetriebenes Werkzeug H=85mm

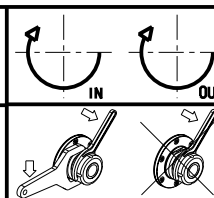

M.T. srl
 Via Casino Albini 480
 Tel. 0541/956034-957884
 Fax 0541/956341
 47842 S. GIOVANNI IN M. (RN)
 e-mail: mtma@mtmarchetti.com
 http://www.mtmarchetti.com

PRODUZIONE MODULI ROTANTI



PAGINA DW0150-5-10-K

Subject to change without notice.

04/2020

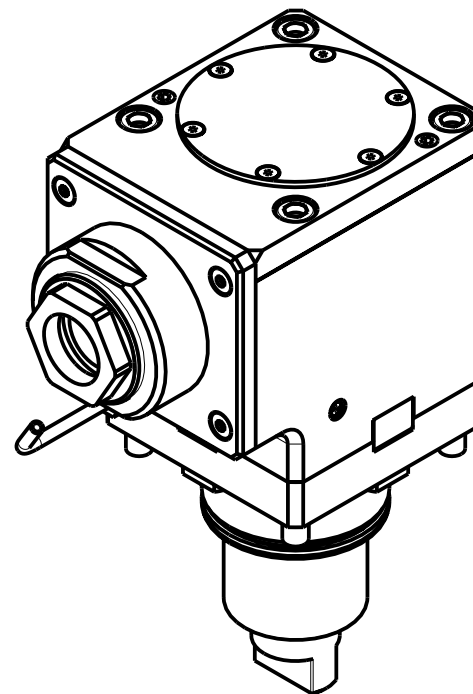
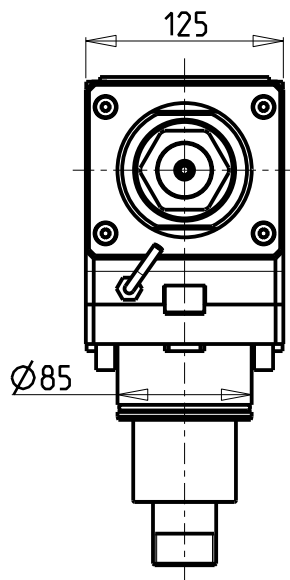
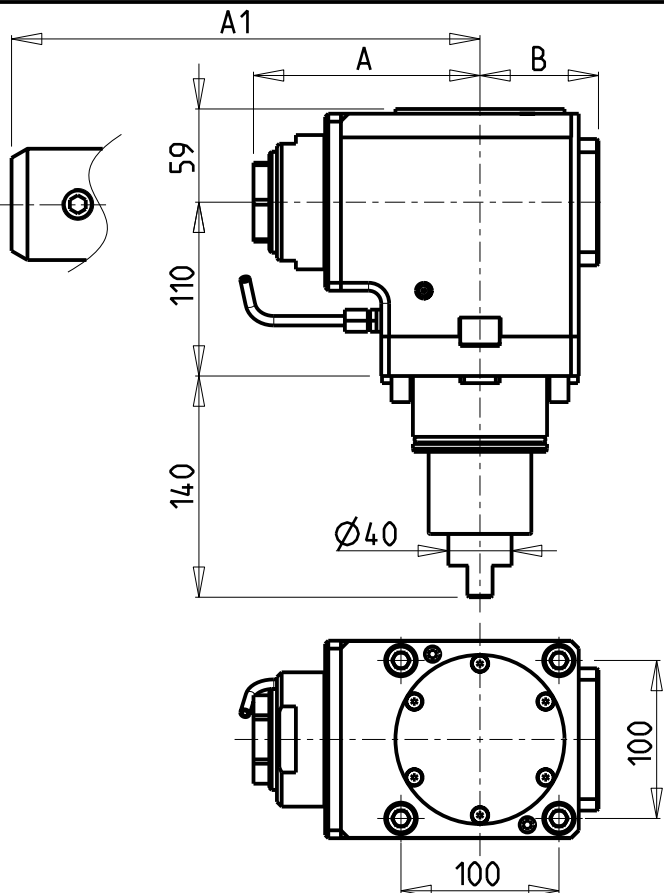

Cod. MT	Mandrino Spindle Spindel	I	RPM	Coppia Max Max Torque Max Drehmoment	Reversibile lato mandrino/contromandrino Reversible sub/main spindle side Umkehrbare Spindel-seite/ Gegenspindel-seite	Lubr.interna Coolant through Innenkuehlung	Lubr. esterna Ext. coolant Aussenkuehlung	A	A1	B	CHIAVI NON INCLUSE Keys not included Schluessel nicht einbegriffen	
DW01290150	ER A 50	1:1	3000	210Nm	X		X	143.33	-	75	CHUB50	CHUB74
DW01291250	ER A 50	1:1	3000	210Nm	X	P=70bar	X	143.33	-	86	CHUB50	CHUB74
DW01290240	Weldon 40	1:1	3000	210Nm	X		X	-	175.5	75	-	-
DW01290140	Weldon 40	1:1	3000	210Nm	X	P=70bar	X	-	175.5	86	-	-

DOOSAN BMT 85

MOD: VT900M/TM - VT1100M - PUMA 600M/LM - PUMA 700M/LM - PUMA 800M/LM

MODULO MOTORIZZATO ASSIALE H=110mm

Axial driven tool H=110mm

Axial angetriebenes Werkzeug H=110mm

Subject to change without notice.

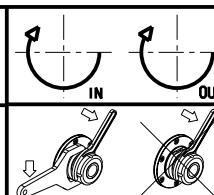

M.T. srl

Via Casino Albini 480
Tel. 0541/956034-957884
Fax 0541/956341

47842 S. GIOVANNI IN M. (RN)
e-mail: mtma@mtmarchetti.com
http://www.mtmarchetti.com

PRODUZIONE MODULI ROTANTI



PAGINA DW0150-5-20

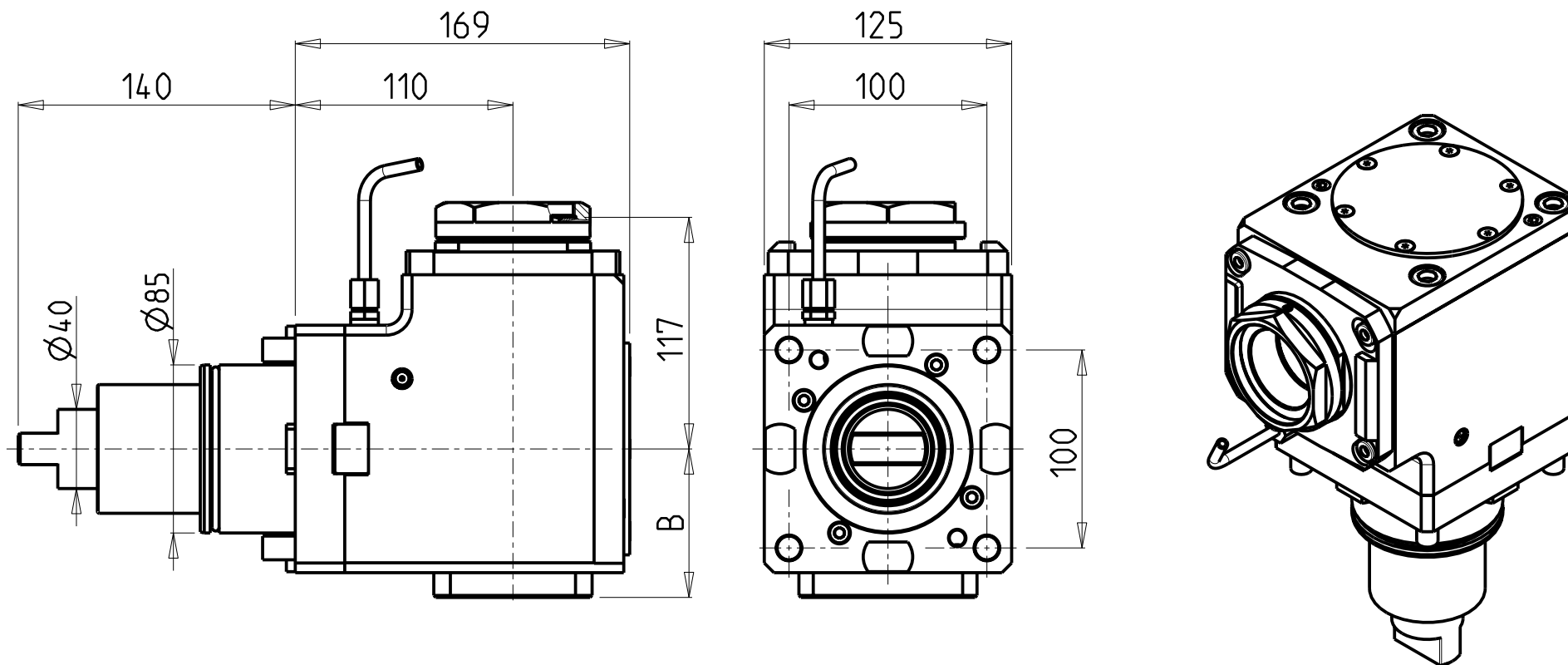

PER PORTAUTENSILI MODULARI MTSK-63 VEDI PAG. TBL300-1-63
 FOR MTSK-63 QUIK CHANGE TOOLHOLDERS CLAMPINGS SEE PAGE TBL300-1-63
 FUER MTSK-63 MODULARE WERKZEUGAUFNAHMEN SIEHE SEITE TBL300-1-63

Cod. MT	Mandrino Spindle Spindel	I	RPM	Coppia Max Max Torque Max Drehmoment	Reversibile lato mandrino/contromandrino Reversible sub/main spindle side Umkehrbare Spindel-seite/ Gegenspindel-seite	Lubr.interna Coolant through Innenkuehlung	Lubr. esterna Ext. coolant Aussenkuehlung	B	CHIAVI NON INCLUDE Keys not included Schluessel nicht einbegriffen	
DW01600163	MTSK-63	1:1	3000	210Nm	X	-	X	75	CHUB68	NZL0010023 ■
DW01600263	MTSK-63	1:1	3000	210Nm	X	P=70bar	X	86	CHUB68	NZL0010023 ■

- Chiave inclusa
- Key included
- Schluessel inbegriffen

DOOSAN BMT 85

MOD: VT900M/TM - VT1100M - PUMA 600M/LM - PUMA 700M/LM - PUMA 800M/LM

MODULO MOTORIZZATO ASSIALE MTSK H=110mm

Axial MTSK driven tool H=110mm

Axial MTSK angetriebenes Werkzeug H=110mm

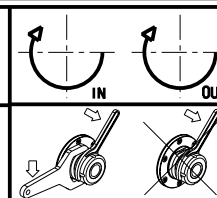

M.T. srl
 Via Casino Albini 480
 Tel. 0541/956034-957884
 Fax 0541/956341
 47842 S. GIOVANNI IN M. (RN)
 e-mail: mtma@mtmarchetti.com
 http://www.mtmarchetti.com

PRODUZIONE MODULI ROTANTI



PAGINA DW0150-5-20-K

Subject to change without notice.

04/2020

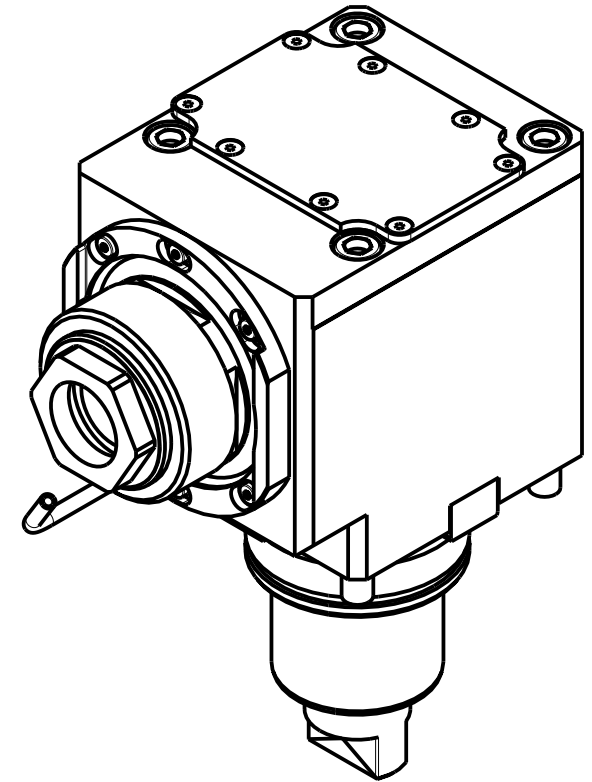
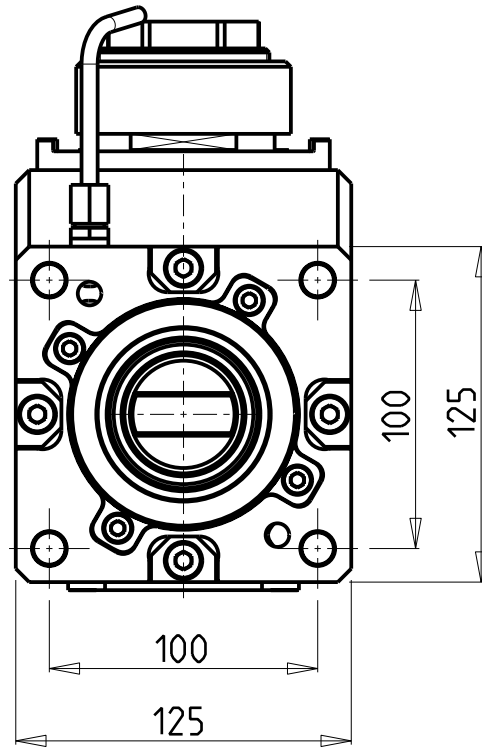
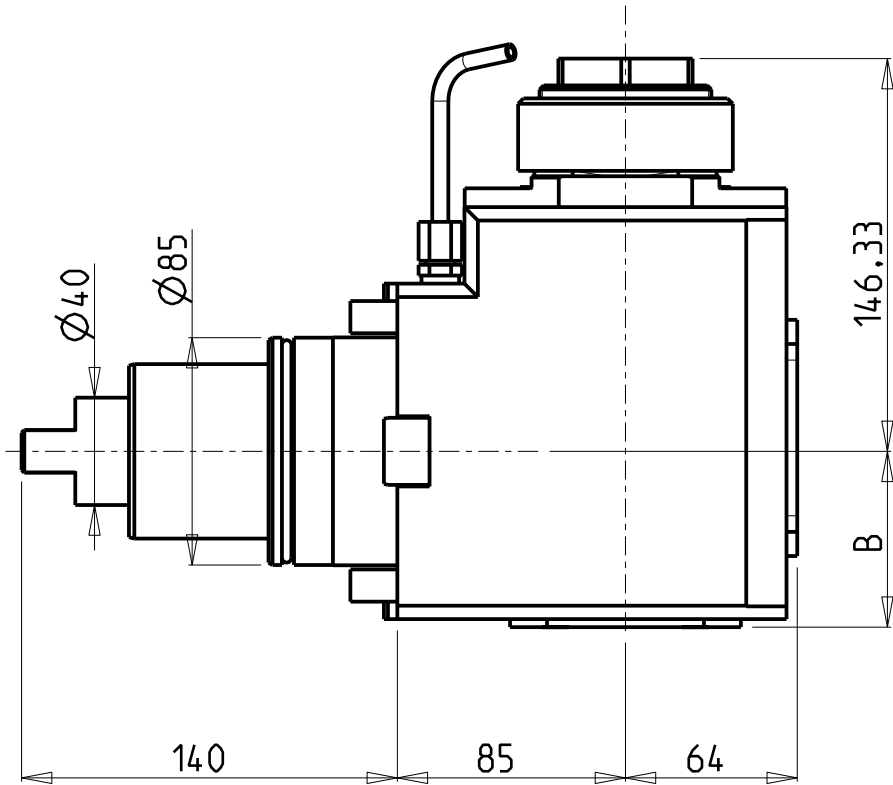

Cod. MT	Mandrino Spindle Spindel	I	RPM	Coppia Max Max Torque Max Drehmoment	Reversibile lato mandrino/contromandrino Reversible sub/main spindle side Umkehrbare Spindel-seite/ Gegenspindel-seite	Lubrificazione int. Coolant through Innenkuhlung	Lubrificazione est. Ext. coolant Aussenkuhlung	B	CHIAVI NON INCLUSE Keys not included Schlüssel nicht einbegriffen	
DW 00460150	ER A 50	2:1	1500	300Nm	X		X	65.5	CHUB50	NZL0010023 •
DW 00460250	ER A 50	2:1	1500	300Nm	X	P=70bar	X	82	CHUB50	NZL0010023 •

- Chiave inclusa
- Key included
- Schlüssel inbegriffen

DOOSAN BMT 85

MOD: VT900M/TM - PUMA 600M/LM - PUMA 700M/LM - PUMA 800M/LM

MODULO MOTORIZZATO ASSIALE RIDOTTO I=2:1 H=85mm

Axial geared-down I=2:1 driven tool H=85mm

Axial angetriebenes Werkzeug untersetzt I=2:1 H=85mm

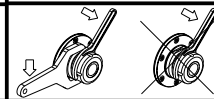
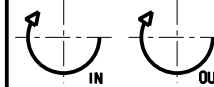

M.T. srl

Via Casino Albini 480
Tel. 0541/956034-957884
Fax 0541/956341
47842 S. GIOVANNI IN M. (RN)
e-mail: mtma@mtmarchetti.com
http://www.mtmarchetti.com

PRODUZIONE MODULI ROTANTI



PAGINA DW 0190-5-10

Subject to change without notice.

04/2020

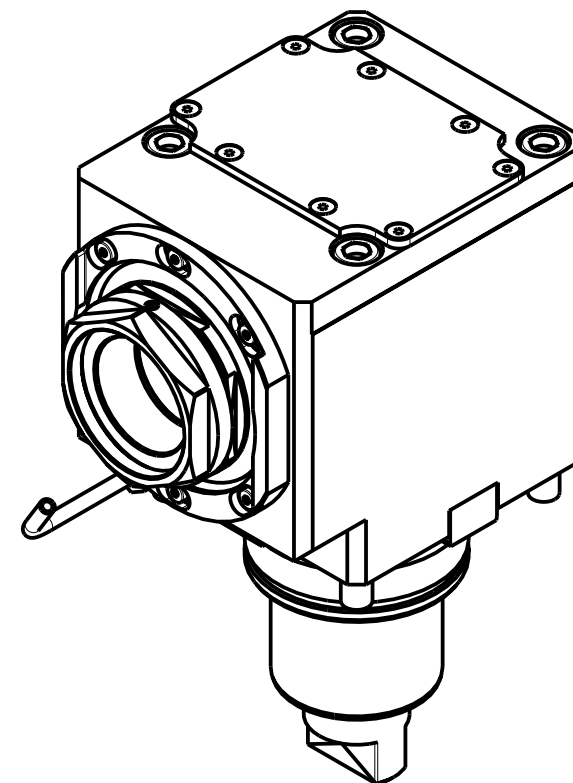
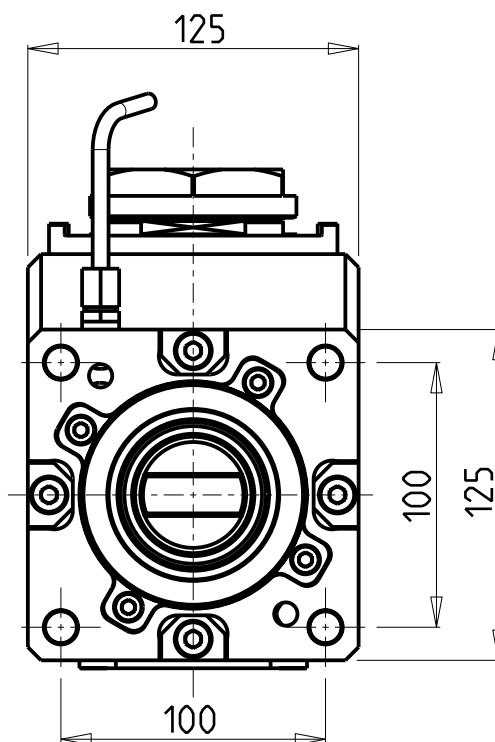
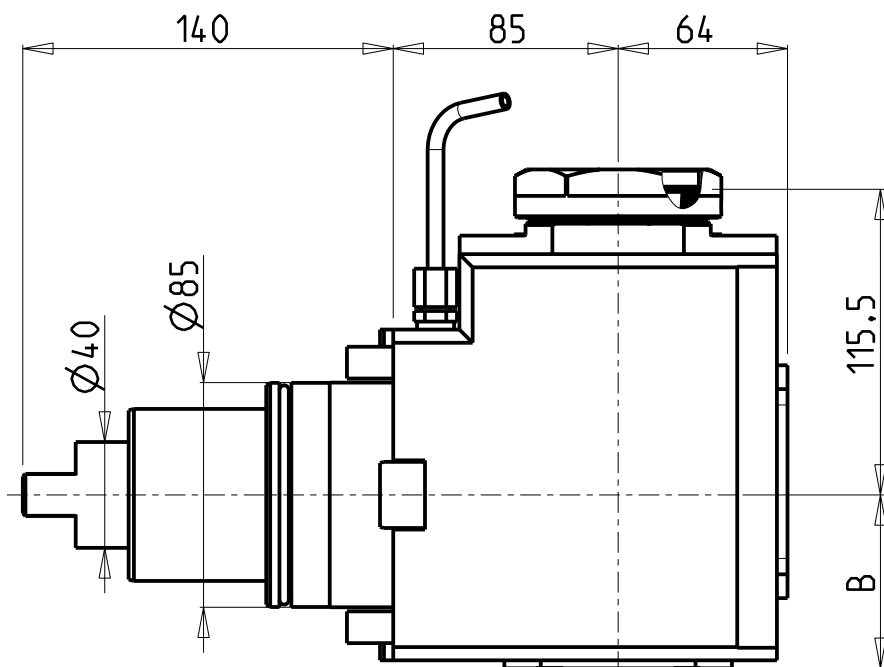

PER PORTAUTENSILI MODULARI MTSK-63 VEDI PAG. TBL300-1-63
 FOR MTSK-63 QUICK CHANGE TOOLHOLDERS CLAMPINGS SEE PAGE TBL300-1-63
 FUER MTSK-63 MODULARE WERKZEUGAUFNAHMEN SIEHE SEITE TBL300-1-63

Cod. MT	Mandrino Spindle Spindel	I	RPM	Coppia Max Max Torque Max Drehmoment	Reversibile lato mandrino/contromandrino Reversible sub/main spindle side Umkehrbare Spindelseite/ Gegenspindelseite	Lubrificazione int. Coolant through Innenkuhlung	Lubrificazione est. Ext. coolant Aussenkuhlung	B	CHIAVI NON INCLUSE Keys not included Schlüssel nicht einbegriffen	
DW 00760163	MTSK-63	2:1	1500	300Nm	X		X	65.5	CHUB68	NZL0010023 •
DW 00760263	MTSK-63	2:1	1500	300Nm	X	P=70bar	X	82	CHUB68	NZL0010023 •

- Chiave inclusa
- Key included
- Schlüssel inbegriffen

DOOSAN BMT 85

MOD: VT900M/TM - PUMA 600M/LM - PUMA 700M/LM - PUMA 800M/LM

MODULO MOTORIZZATO ASSIALE MTSK RIDOTTO I=2:1 H=85mm

Axial MTSK geared-down I=2:1 driven tool H=85mm

Axial MTSK angetriebenes Werkzeug untersetzt I=2:1 H=85mm

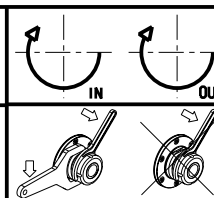

M.T. srl
 Via Casino Albini 480
 Tel. 0541/956034-957884
 Fax 0541/956341
 47842 S. GIOVANNI IN M. (RN)
 e-mail: mtma@mtmarchetti.com
 http://www.mtmarchetti.com

PRODUZIONE MODULI ROTANTI



PAGINA DW0190-5-10-K

Subject to change without notice.

04/2020

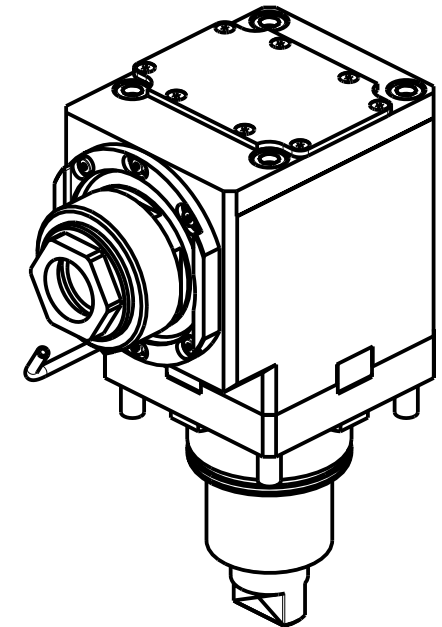
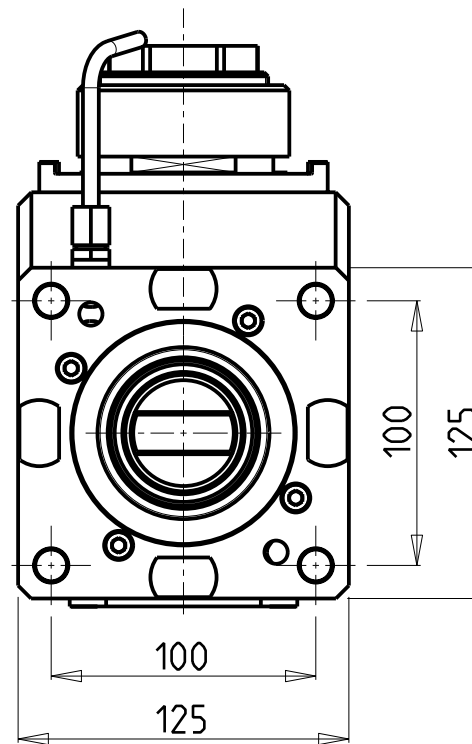
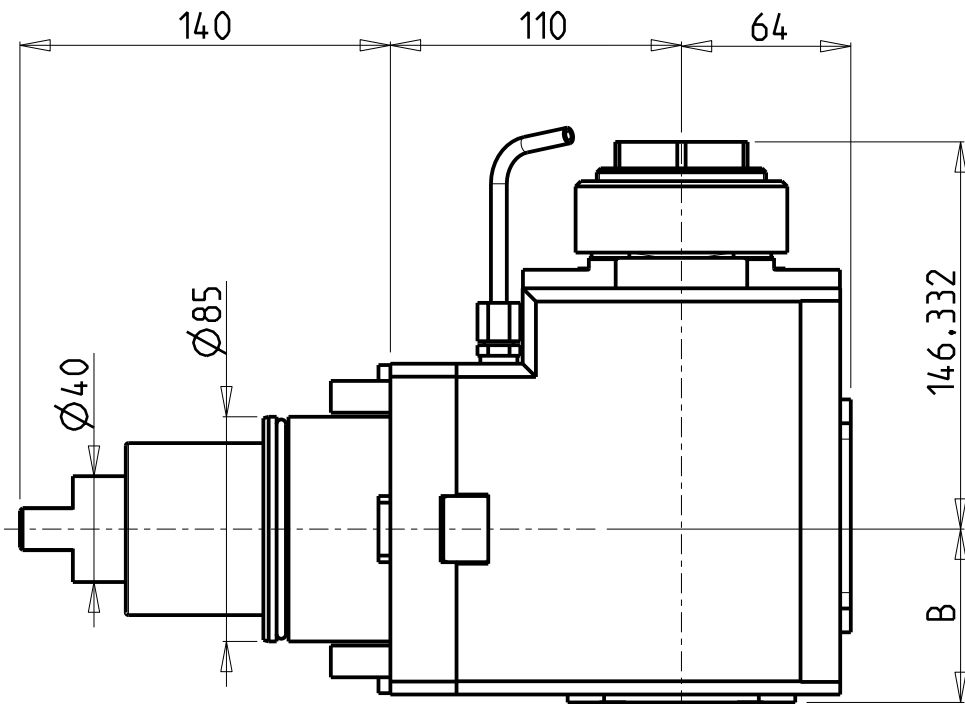

Cod. MT	Mandrino Spindle Spindel	I	RPM	Coppia Max Max Torque Max Drehmoment	Reversibile lato mandrino/contromandrino Reversible sub/main spindle side Umkehrbare Spindel-seite/ Gegenspindel-seite	Lubrificazione int. Coolant through Innenkuhlung	Lubrificazione est. Ext. coolant Aussenkuhlung	B	CHIAVI NON INCLUSE Keys not included Schlüssel nicht einbegriffen	
DW01210150	ER A 50	2:1	1500	300Nm	X		X	65.5	CHUB50	NZL0010023 •
DW01210250	ER A 50	2:1	1500	300Nm	X	P=70bar	X	82	CHUB50	NZL0010023 •

• Chiave inclusa
• Key included
• Schlüssel inbegriffen

DOOSAN BMT 85

MOD: VT900M/TM - VT1100M - PUMA 600M/LM - PUMA 700M/LM - PUMA 800M/LM

MODULO MOTORIZZATO ASSIALE RIDOTTO I=2:1 H=110mm

Axial geared-down I=2:1 driven tool H=110mm

Axial angetriebenes Werkzeug untersetzt I=2:1 H=110mm

Subject to change without notice.

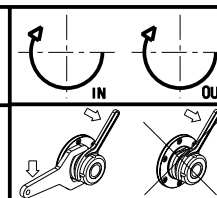

M.T. srl

Via Casino Albini 480
Tel. 0541/956034-957884
Fax 0541/956341
47842 S. GIOVANNI IN M. (RN)
e-mail: mtma@mtmarchetti.com
http://www.mtmarchetti.com

PRODUZIONE MODULI ROTANTI



PAGINA DW0190-5-20

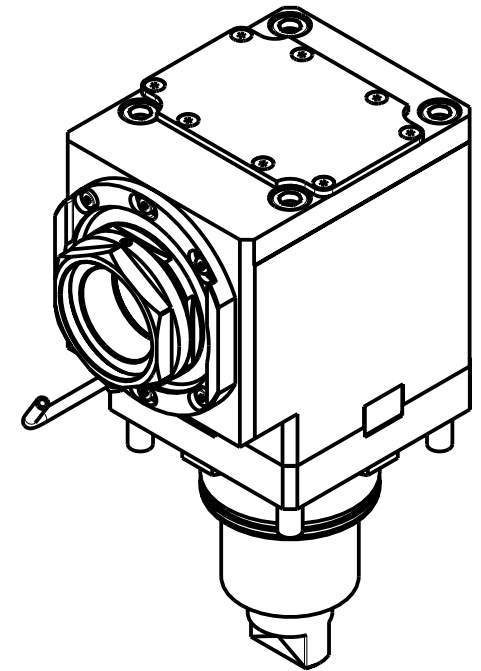
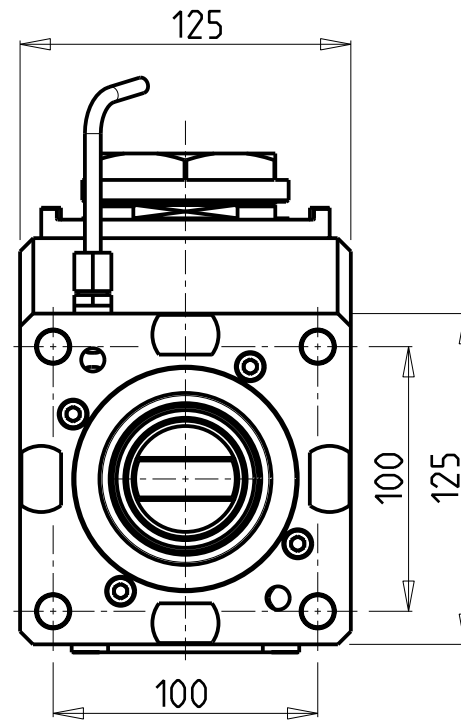
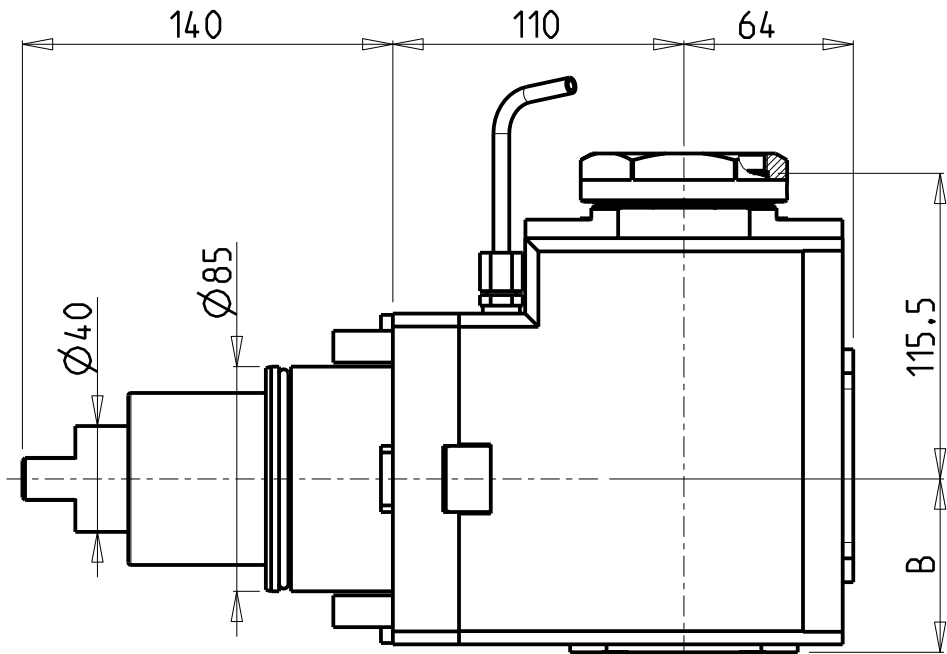

PER PORTAUTENSILI MODULARI MTSK-63 VEDI PAG. TBL300-1-63
 FOR MTSK-63 QUIK CHANGE TOOLHOLDERS CLAMPINGS SEE PAGE TBL300-1-63
 FUER MTSK-63 MODULARE WERKZEUGAUFNAHMEN SIEHE SEITE TBL300-1-63

Cod. MT	Mandrino Spindle Spindel	I	RPM	Coppia Max Max Torque Max Drehmoment	Reversibile lato mandrino/contromandrino Reversible sub/main spindle side Umkehrbare Spindel-seite/ Gegenspindel-seite	Lubrificazione int. Coolant through Innenkuhlung	Lubrificazione est. Ext. coolant Aussenkuhlung	B	CHIAVI NON INCLUSE Keys not included Schlüssel nicht einbegriffen	
DW01200163	MTSK-63	2:1	1500	300Nm	X		X	65.5	CHUB68	NZL0010023 •
DW01200263	MTSK-63	2:1	1500	300Nm	X	P=70bar	X	82	CHUB68	NZL0010023 •

- Chiave inclusa
- Key included
- Schlüssel inbegriffen

DOOSAN BMT 85
 MOD: VT900M/TM - VT1100M - PUMA 600M/LM - PUMA 700M/LM - PUMA 800M/LM

MODULO MOTORIZZATO ASSIALE MTSK RIDOTTO I=2:1 H=110mm
 Axial MTSK geared-down I=2:1 driven tool H=110mm
 Axial MTSK angetriebenes Werkzeug untersetzt I=2:1 H=110mm

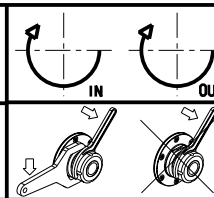

M.T. srl
 Via Casino Albini 480
 Tel. 0541/956034-957884
 Fax 0541/956341
 47842 S. GIOVANNI IN M. (RN)
 e-mail: mtma@mtmarchetti.com
 http://www.mtmarchetti.com

PRODUZIONE MODULI ROTANTI

PAGINA DW0190-5-20-K

Subject to change without notice.

04/2020

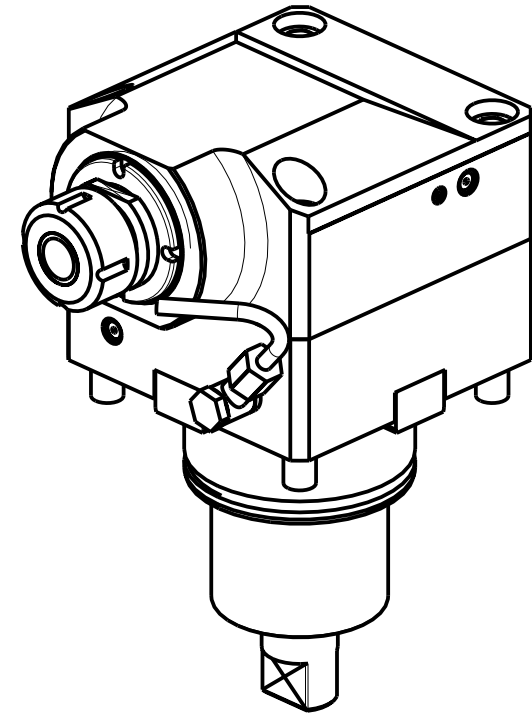
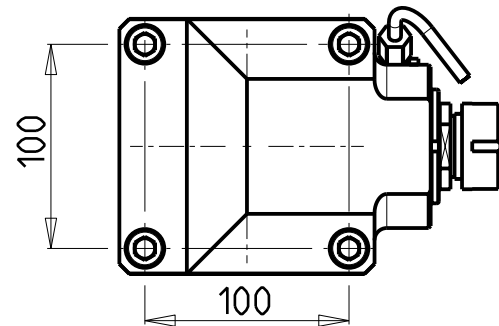
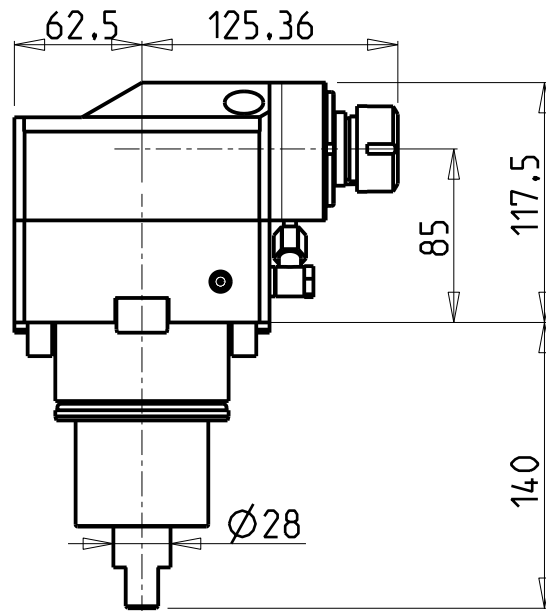
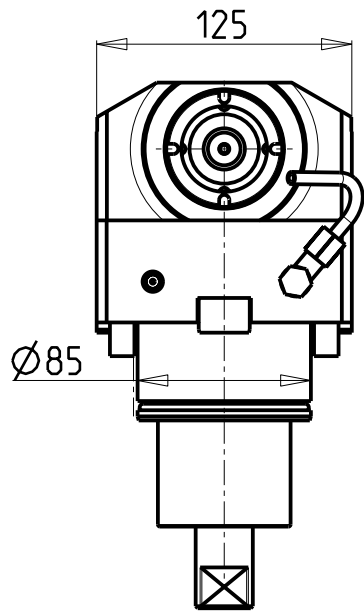

Cod. MT	Mandrino Spindle Spindel	i	RPM MAX	Coppia Max Max Torque Max Drehmoment	Lubrificazione int. Coolant through Innenkuehlung	Lubrificazione est. Ext. coolant Aussenkuehlung	CHIAVI NON INCLUDE Keys not included Schluessel nicht einbegriffen	
							CHSTER25	CHUB36
DW 00580125	ER25	1:3	9000	70Nm	-	X	CHSTER25	CHUB36
DW 00580225	ER25	1:3	9000	70Nm	P=70bar	X	CHSTER25	CHUB36

DOOSAN BMT 85

MOD: VT900M/TM - PUMA 600M/LM - PUMA 700M/LM - PUMA 800M/LM

MODULO MOTORIZZATO ASSIALE MOLTIPLICATO I=1:3

Axial geared-up I=1:3 driven tool

Axial angetriebenes Werkzeug uebersetzt I=1:3

Subject to change without notice.

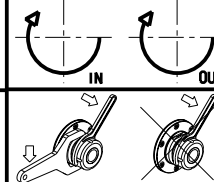

M.T. srl
 Via Casino Albini 480
 Tel. 0541/956034-957884
 Fax 0541/956341
 47842 S. GIOVANNI IN M. (RN)
 e-mail: mtma@mtmarchetti.com
 http://www.mtmarchetti.com

PRODUZIONE MODULI ROTANTI



PAGINA DW 0205-5-10

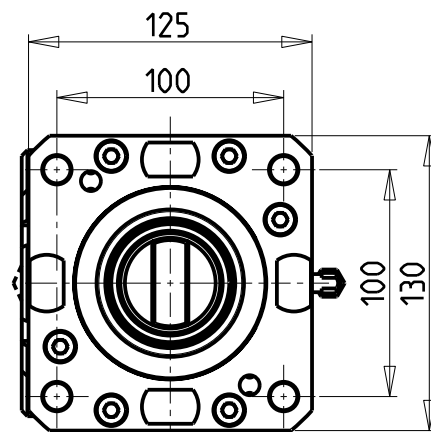
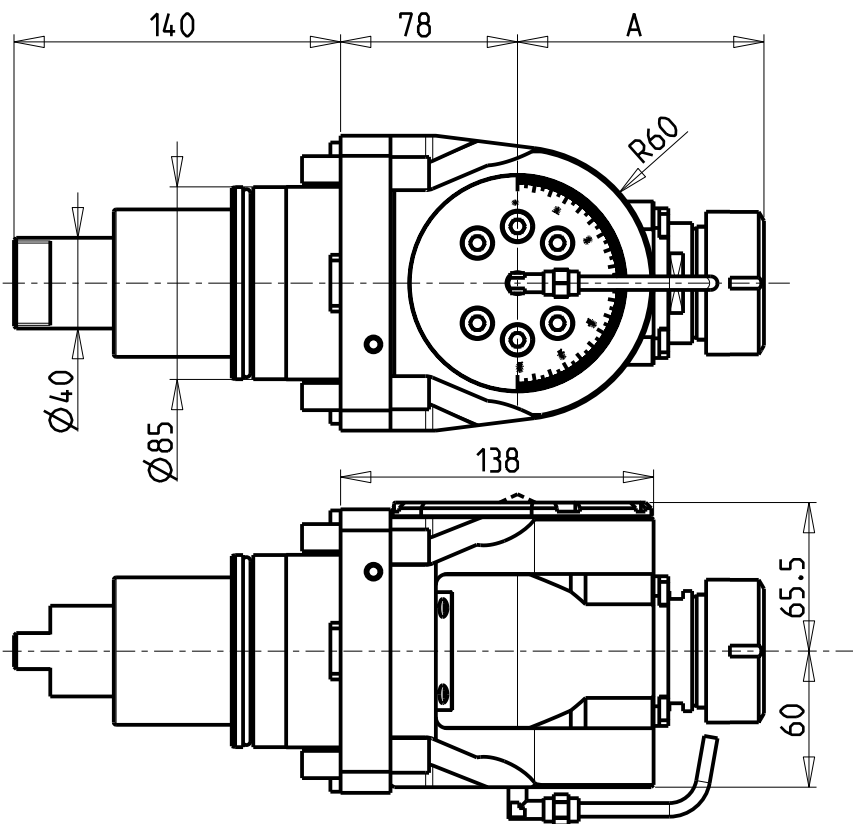

ATTENZIONE - ATTENTION - ACHTUNG

- Per lo smontaggio degli utensili utilizzare sempre la chiave di contrasto come indicato nel manuale d'uso.
- For disassembly of the tools use always the contrast key as mentioned in the user instructions.
- Fuer das Abmontieren der Werkzeuge immer den Gegenschlüssel benutzen wie in der Bedienungsanleitung erwaehnt.

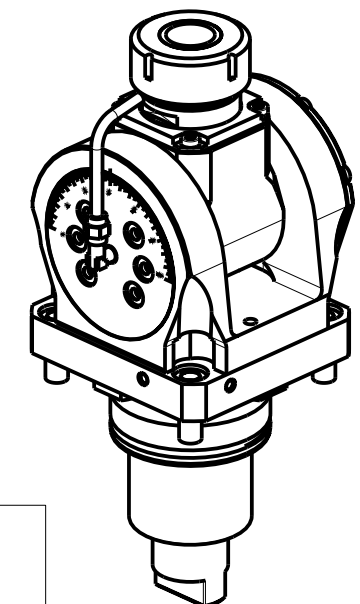

Cod. MT	Mandrino Spindle Spindel	I	RPM	Coppia Max Max Torque Max Drehmoment	Lubrificazione int. Coolant through Innenkuehlung	Lubrificazione est. Ext. coolant Aussekuehlung	A	CHIAVI INCLUSE Keys included Schluessel inbegriffen				
								CHUB30	CHUB46	CHTAER32ZC	CHESL10	CHESL06
DW00830332	ERA32	1:1	3000	50Nm		X	81	CHUB30	CHUB46	CHTAER32ZC	CHESL10	CHESL06
DW00830432	ERA32	1:1	3000	50Nm	P=70bar	X	81	CHUB30	CHUB46	CHTAER32ZC	CHESL10	CHESL06
DW00830140	ER40	1:1	3000	50Nm		X	108.66	-	CHUB46	CHSTER40	CHESL10	CHESL06
DW00830240	ER40	1:1	3000	50Nm	P=70bar	X	108.66	-	CHUB46	CHSTER40	CHESL10	CHESL06

DOOSAN BMT 85
 MOD: VT900M/TM - VT1100M - PUMA 600M/LM - PUMA 700M/LM - PUMA 800M/LM

MODULO MOTORIZZATO ORIENTABILE +/-90°
 +/-90° adjustable angle driven tool
 Angetriebenes Werkzeug schwenkbar +/-90°

Subject to change without notice.

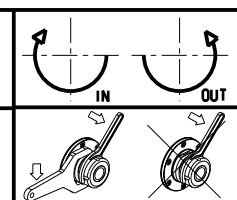

M.T. srl
 Via Casino Albini 480
 Tel. 0541/956034-957884
 Fax 0541/956341
 47842 S. GIOVANNI IN M. (RN)
 e-mail: mtma@mtmarchetti.com
 http://www.mtmarchetti.com

PRODUZIONE MODULI ROTANTI



PAGINA DW0339-5-00

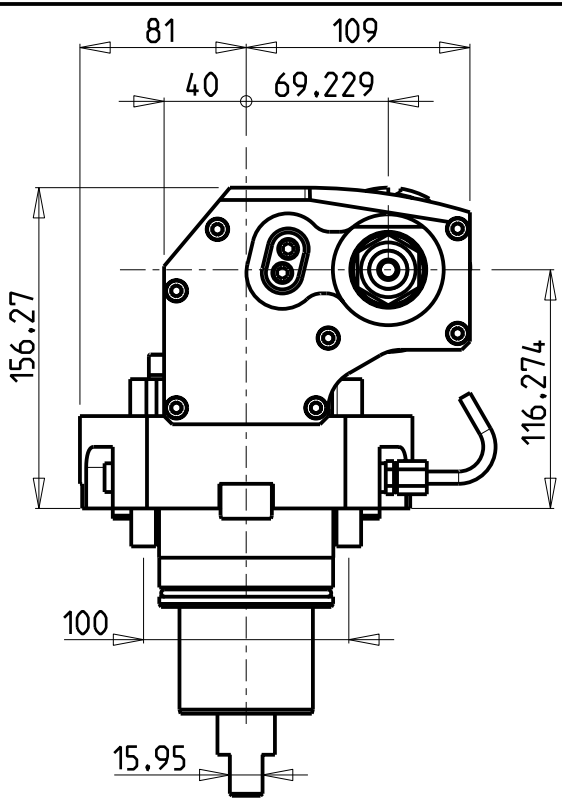
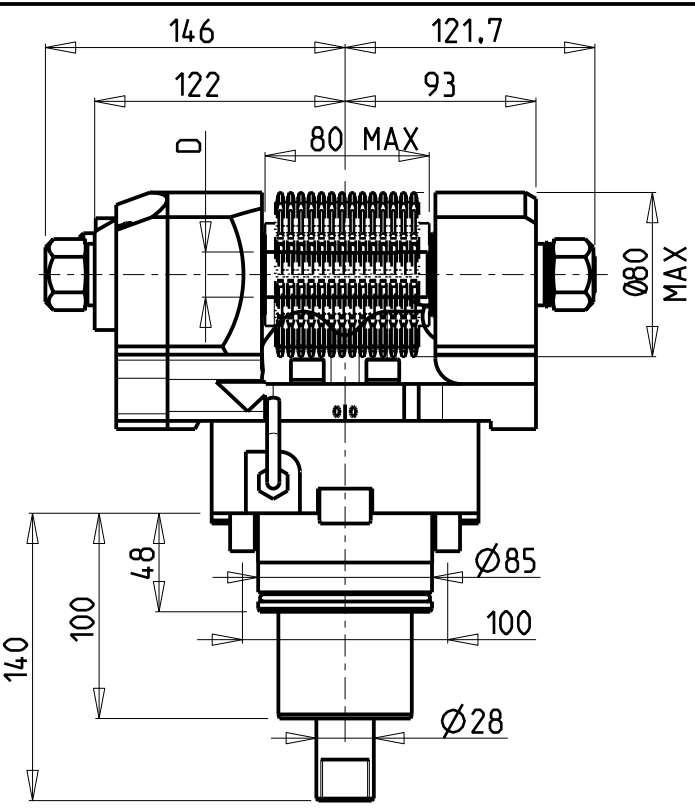

INCLINAZIONE
REGOLABILE ±30°

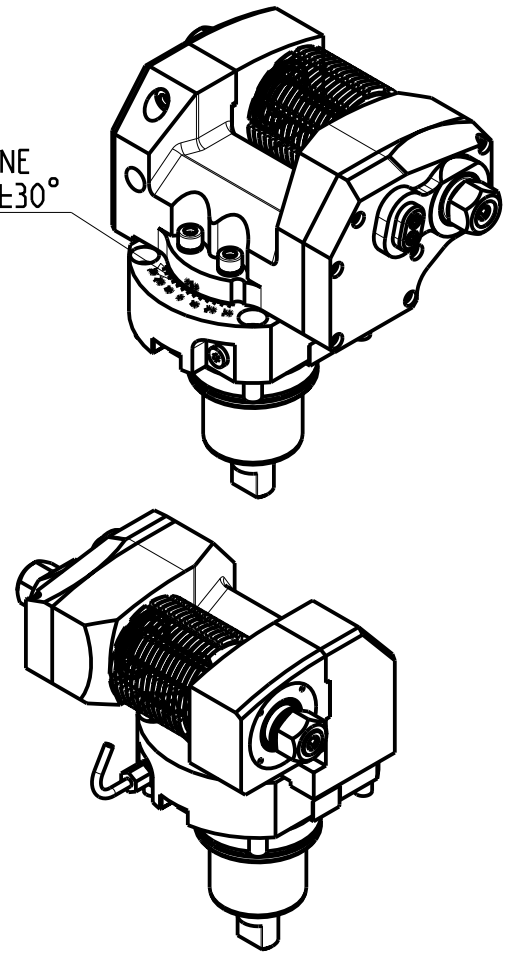

DOTAZIONI - SUPPLIED WITH - AUSSTATTUNG

- N°1 ALBERO + DISTANZIALI
- N°1 SHAFT + SPACER
- N°1 DORN + ABSTANDSSTUECK

PER ALBERI E DISTANZIALI VEDI PAG. TBL250-1-00
FOR SHAFT END SPACER SEE PAGE TBL250-1-00
FUER DORN UND ABSTANDSSTUECK SEITE TBL250-1-00

Cod. MT	I	RPM MAX	Coppia Max Max Torque Max Drehmoment	Lubrificazione est. Ext. coolant Aussenkuehlung	D (mm)	D (Inch)	CHIAVI INCLUSE Keys included Schlüssel inbegriffen			
							CHUB30	CHESL08	CHESL10	CHUB24 (Ø16 / Ø3/4")
DW00181100	1:1	3000	90Nm	X	16-22-27-32	3/4"-1"-1 1/4"	CHUB30	CHESL08	CHESL10	CHUB24 (Ø16 / Ø3/4")
DW00182100	2:1	1500	110Nm	X	16-22-27-32	3/4"-1"-1 1/4"	CHUB30	CHESL08	CHESL10	CHUB24 (Ø16 / Ø3/4")

DOOSAN BMT 85
MOD: VT900M/TM - VT1100M - PUMA 600M/LM - PUMA 700M/LM - PUMA 800M/LM

MODULO MOTORIZZATO PORTACREATORE MAGGIORATO
Reinforced driven gear hobber
Angetriebenes Zahnradwaelzfraes-Werkzeug vergroessert

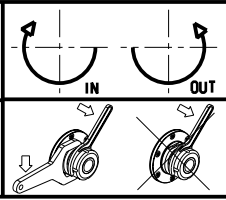

M.T. srl
Via Casino Albini 480
Tel. 0541/956034-957884
Fax 0541/956341
47842 S. GIOVANNI IN M. (RN)
e-mail: mtma@mtmarchetti.com
http://www.mtmarchetti.com

PRODUZIONE MODULI ROTANTI



PAGINA DW0340-5-60

Subject to change without notice.

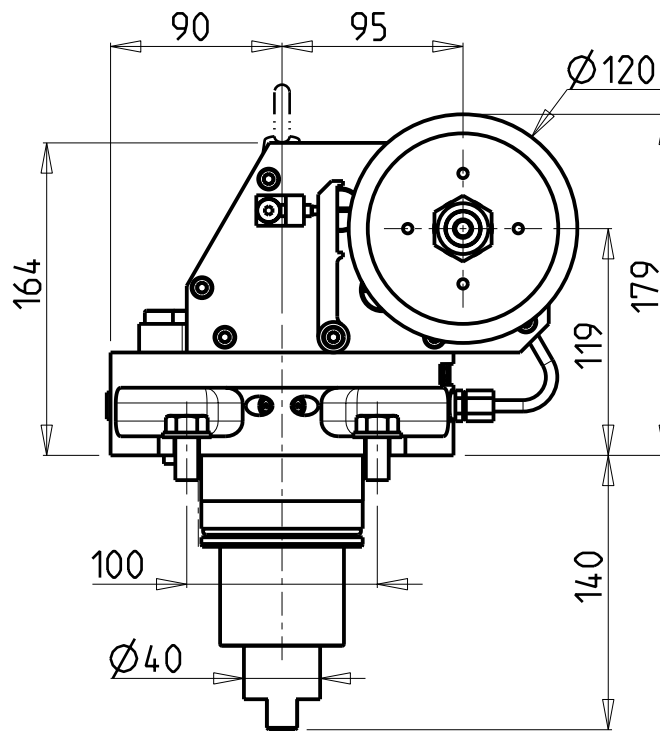
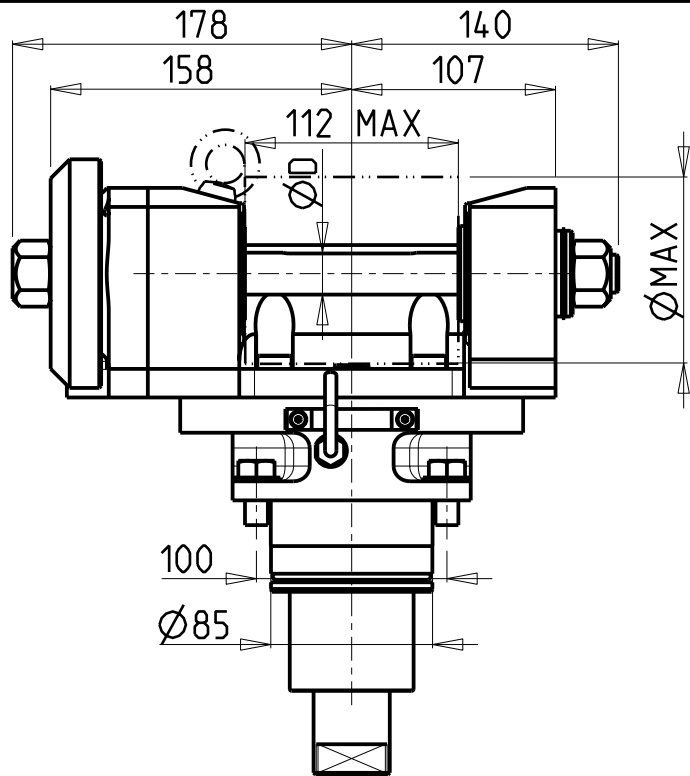

D (mm)	ØMAX (mm)
22	89
27-32	100

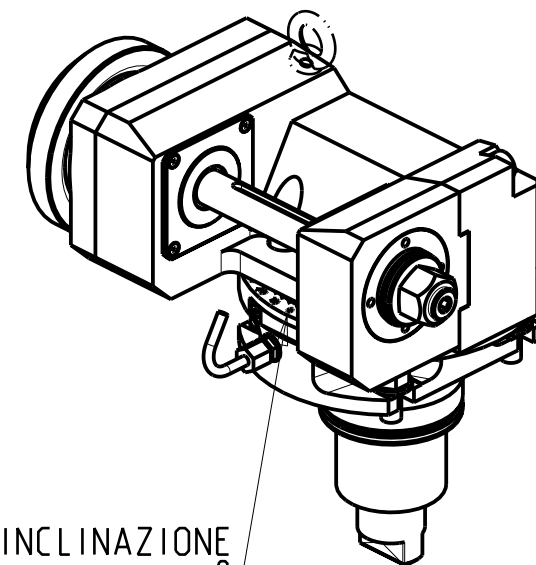

INCLINAZIONE
REGOLABILE ±180°

DOTAZIONI - SUPPLIED WITH - AUSSTATTUNG

- | mm / inch | |
|-----------|-----------------------------|
| | - N°1 ALBERO + DISTANZIALI |
| | - N°1 SHAFT + SPACER |
| | - N°1 DORN + ABSTANDSSTUECK |

PER ALBERI E DISTANZIALI VEDI PAG. TBL250-1-00
FOR SHAFT END SPACER SEE PAGE TBL250-1-00
FUER DORN UND ABSTANDSSTUECK SEITE TBL250-1-00

Cod. MT	i	RPM max	Coppia Max Max Torque Max Drehmoment	Lubrificazione est. Ext. coolant Aussenkuehlung	D (mm)	CHIAVI INCLUSE Keys included Schluessel inbegriffen			
						CHUB30	CHESL08	CHESL10	CHUB19
DW 00851100	1:1	3000	110Nm	X	22-27-32	CHUB30	CHESL08	CHESL10	CHUB19
DW 00852100	2:1	1500	130Nm	X	22-27-32	CHUB30	CHESL08	CHESL10	CHUB19

DOOSAN BMT 85

MOD: VT900M/TM - VT1100M - PUMA 600M/LM - PUMA 700M/LM - PUMA 800M/LM

MODULO MOTORIZZATO PORTACREATORE (TAGLIA GRANDE)

Driven gear hobber (big size)

Angetriebenes Zahnradwaeltzraes-Werkzeug (grosse version)

Subject to change without notice.

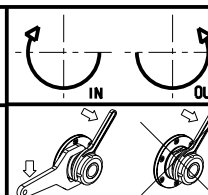

M.T. srl

Via Casino Albini 480
Tel. 0541/956034-957884
Fax 0541/956341
47842 S. GIOVANNI IN M. (RN)
e-mail: mtma@mtmarchetti.com
http://www.mtmarchetti.com

PRODUZIONE MODULI ROTANTI



PAGINA DW0340-5-80

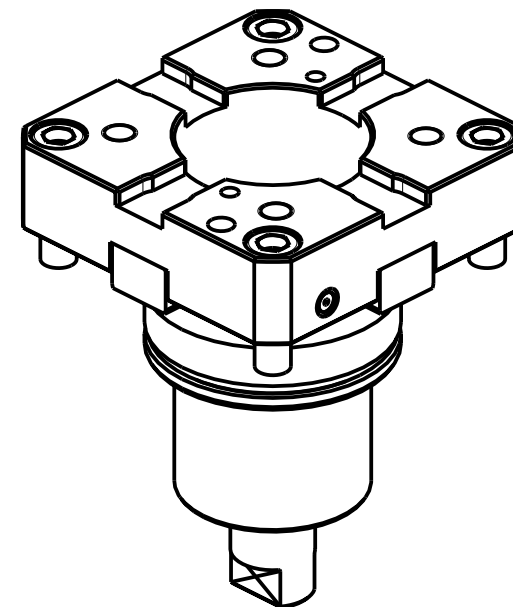
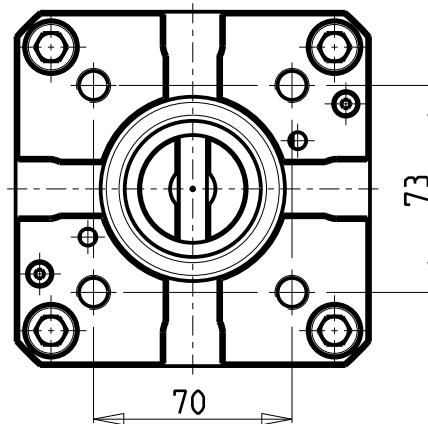
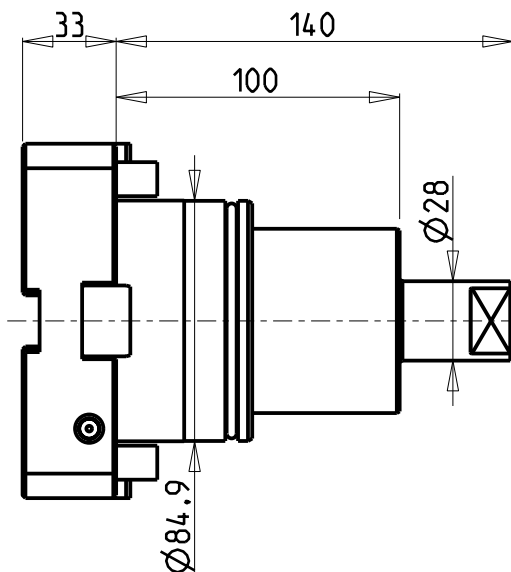
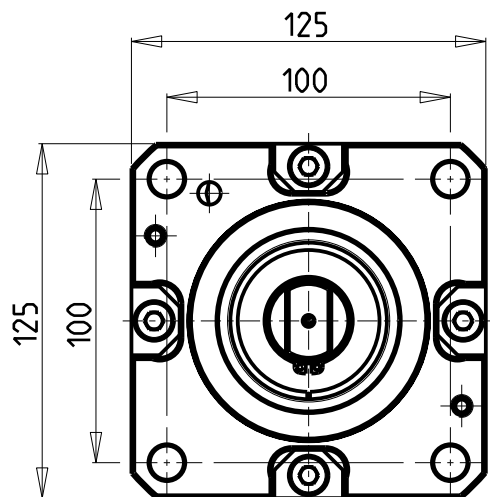

ATTENZIONE - ATTENTION - ACHTUNG

-PERICOLO COLLISIONE PEZZO FUORI VOLTEGGIO

-Danger of collision! Tooling out of interference

-Kollisionsgefahr! Werkzeug ausser Interferenz

Cod. MT

DW00370100

DOOSAN BMT 85

MOD: VT900M/TM - VT1100M - PUMA 600M/LM - PUMA 700M/LM - PUMA 800M/LM

INTERFACCIA PER MODULI BMT-65 H=33mm

BMT-65 tooling adapter cartridge H=33mm

Adapter-Patrone fuer BMT-65 werkzeuge H=33mm

Subject to change without notice.

M.T. srl

Via Casino Albini 480
Tel. 0541/956034-957884

Fax 0541/956341

47842 S. GIOVANNI IN M. (RN)
e-mail: mtma@mtmarchetti.com
http://www.mtmarchetti.com

PRODUZIONE MODULI ROTANTI



PAGINA DW0385-5-00

04/2020

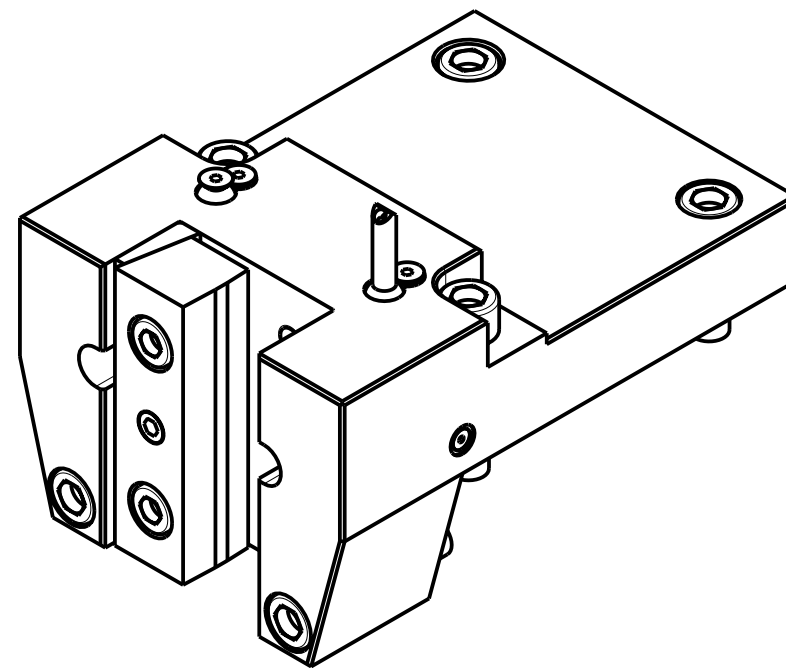
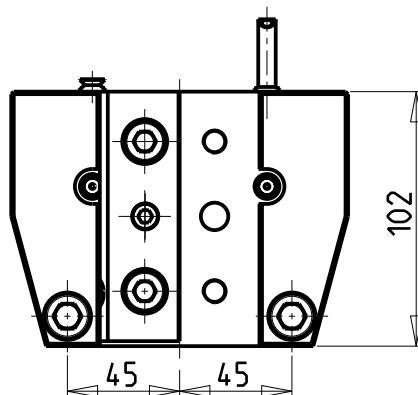
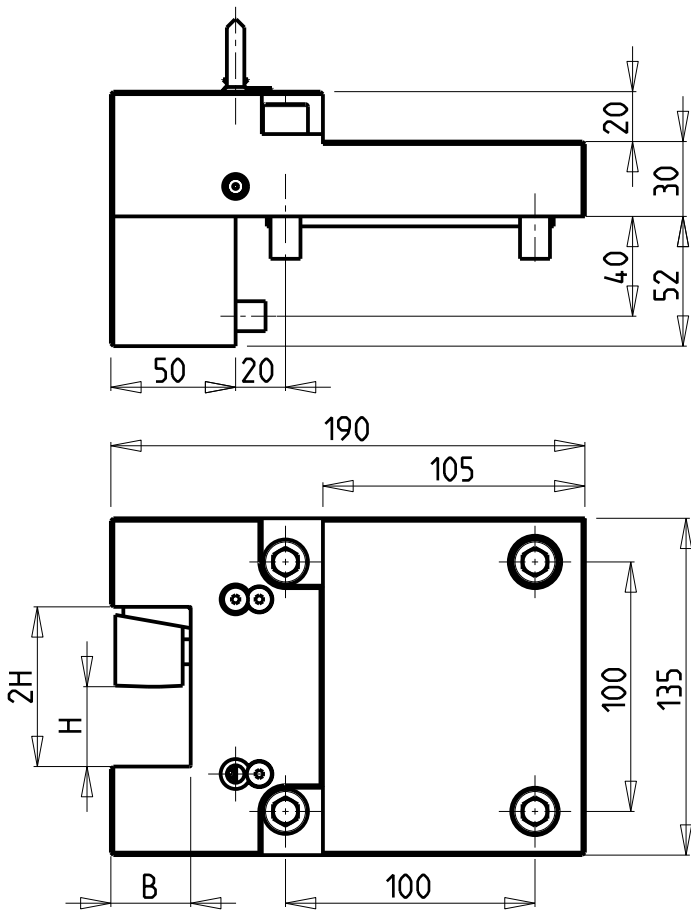

Cod. MT	N°Utensili N°Tools N°Werkzeuge	Misure Dimensions Masse	B	H
DW00323200	1	mm	32	32
DW00323175	1	Inch	1-1/4"	1-1/4"

DOOSAN BMT 85

MOD: VT900M/TM - VT1100M - PUMA 600M/LM - PUMA 700M/LM - PUMA 800M/LM

PORTAUTENSILE RADIALE SINGOLO QD=32mm / QD=1 1/4"

Radial single static tool QD=32mm / QD=1 1/4"

Radial Single-Werkzeughalter QD=32mm / QD=1 1/4"

Subject to change without notice.

M.T. srl
 Via Casino Albini 480
 Tel. 0541/956034-957884
 Fax 0541/956341
 47842 S. GIOVANNI IN M. (RN)
 e-mail: mtma@mtmarchetti.com
 http://www.mtmarchetti.com

PRODUZIONE MODULI ROTANTI

PAGINA DW0423-5-00

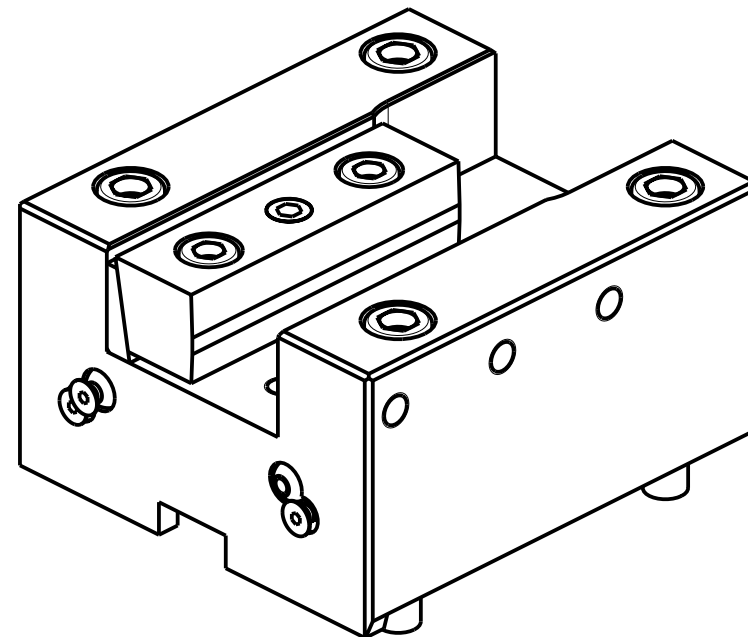
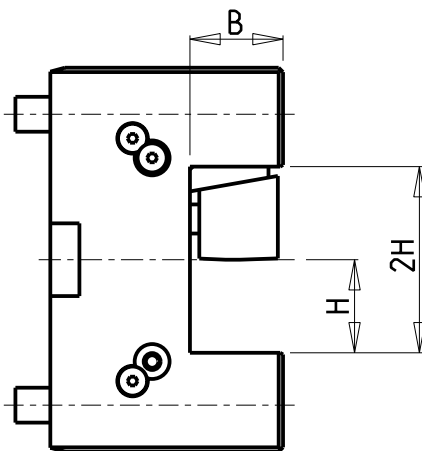
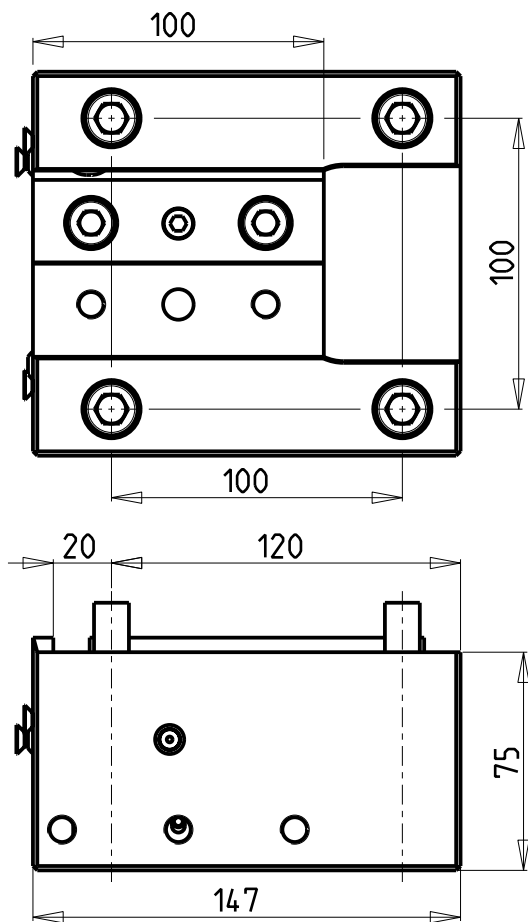

Cod. MT	N°Utensili N° Tools N° Werkzeuge	Reversibile lato mandrino/contromandrino Reversible sub/main spindle side Umkehrbare Spindelseite/ Gegenspindelseite	Misure Dimensions Masse	B	H
DW 00333200	1/2	X	mm	32	32
DW 00333175	1/2	X	Inch	1-1/4"	1-1/4"

DOOSAN BMT 85

MOD: VT900M/TM - VT1100M - PUMA 600M/LM - PUMA 700M/LM - PUMA 800M/LM

PORTAUTENSILE ASSIALE SINGOLO QD=32mm / QD=1 1/4"

Axial single static tool QD=32mm / QD=1 1/4"

Axial Single-Werkzeughalter QD=32mm / QD=1 1/4"

Subject to change without notice.

M.T. srl

Via Casino Albini 480
Tel. 0541/956034-957884
Fax 0541/956341

47842 S. GIOVANNI IN M. (RN)
e-mail: mtma@mtmarchetti.com
http://www.mtmarchetti.com

PRODUZIONE MODULI ROTANTI



PAGINA DW0552-5-00

04/2020

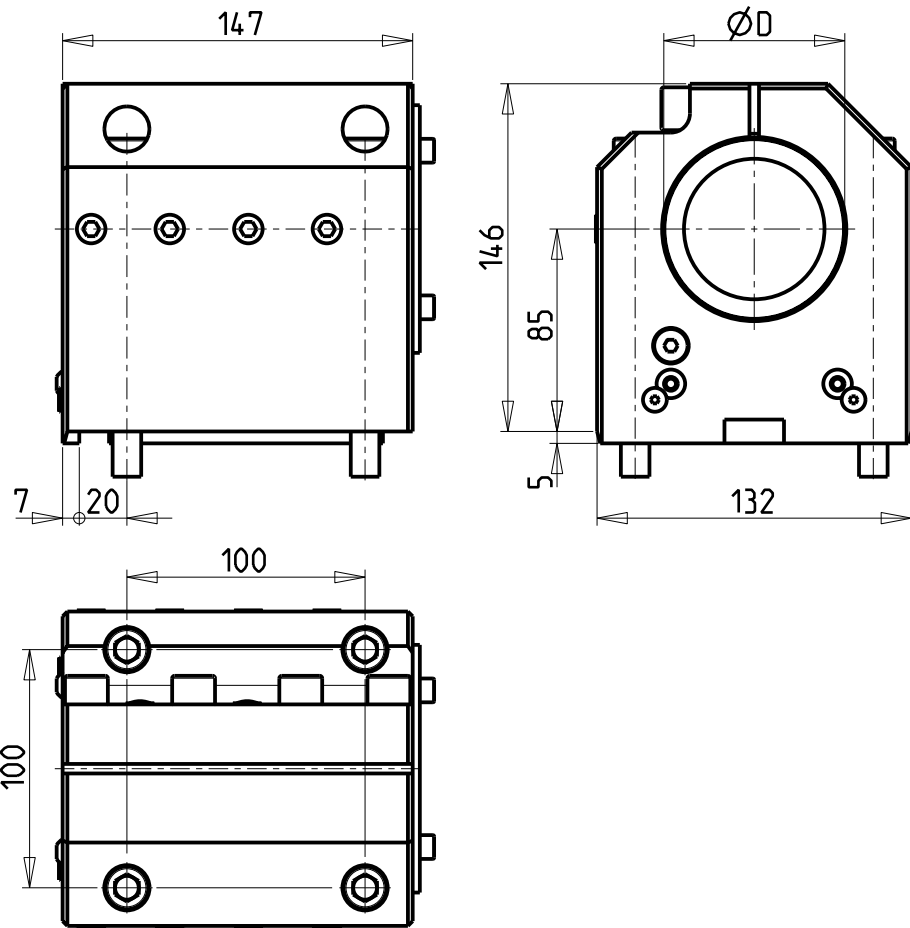

KIT ADDUZIONE INTERNA (OPZIONALE)
 KIT FOR INTERNAL COOLANT (OPTIONAL)
 KIT FUER INTERNE KUEHLMITTELZUFUHR (OPTIONAL)
 Ø80 cod. KIT1002013
 Ø3" cod. KIT1002014

SOLO GUARNIZIONE (OPZIONALE)
 ONLY SEAL (OPTIONAL)
 NUR DICHTUNG (OPTIONAL)
 cod. MNL0310005

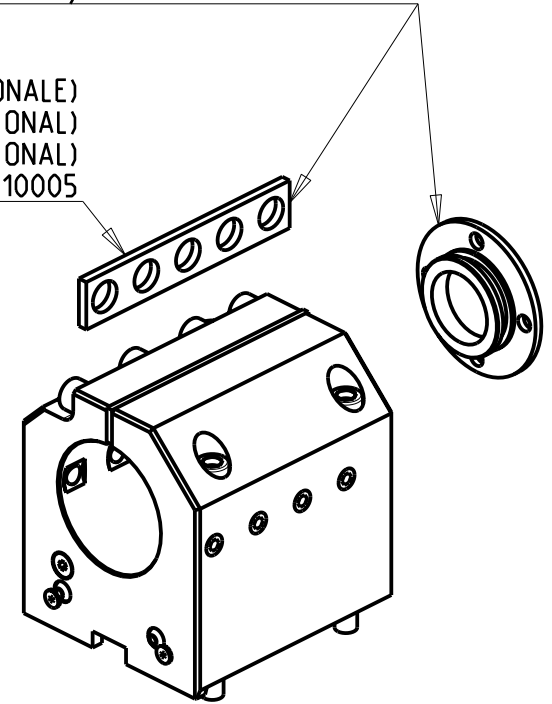

Cod. MT	N°Utensili N°Tools N°Werkzeuge	Reversibile lato mandrino/contromandrino Reversible sub/main spindle side Umkehrbare Spindel-seite/ Gegenspindel-seite	Lubrificazione int. opzionale Coolant through optional Innenkuehlung Optional	Lubrificazione est. Ext. coolant Aussenkuehlung	Misure Dimensions Masse	D
DW00348000	1	X	X	X	mm	80
DW00347620	1	X	X	X	Inch	3"

DOOSAN BMT 85

MOD: VT900M/TM - PUMA 600M/LM - PUMA 700M/LM - PUMA 800M/LM

PORTAUTENSILE ASSIALE PER BARENO Ø80mm / Ø3" H=85mm

Axial single boring bar holder Ø80mm / Ø3" H=85mm

Axial Bohrhälter Ø80mm / Ø3" H=85mm

Subject to change without notice.

M.T. srl

Via Casino Albini 480
 Tel. 0541/956034-957884
 Fax 0541/956341
 47842 S. GIOVANNI IN M. (RN)
 e-mail: mtma@mtmarchetti.com
 http://www.mtmarchetti.com

PRODUZIONE MODULI ROTANTI



PAGINA DW0580-5-20

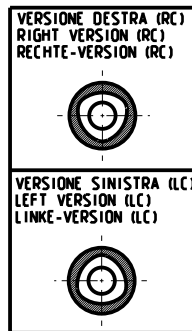
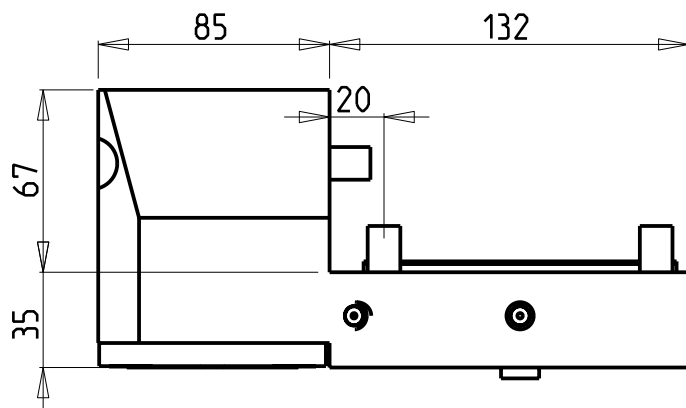
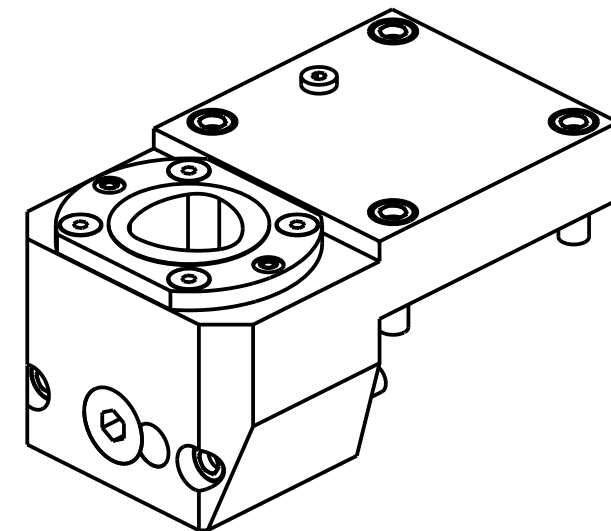
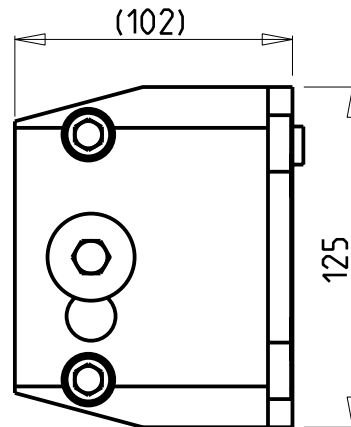
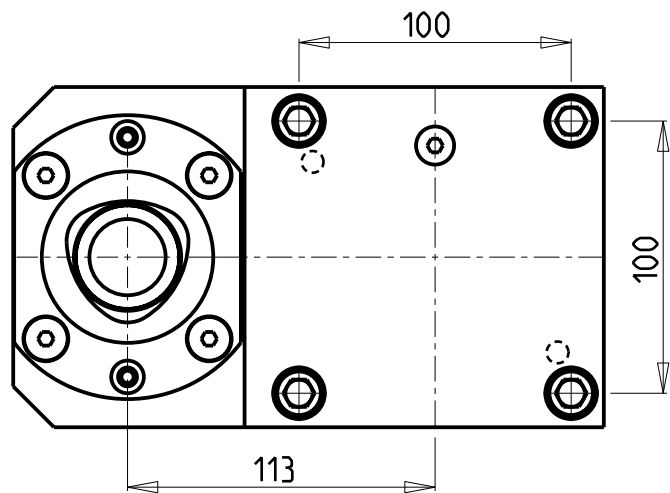

PER ORDINARE LA VERSIONE SX
AGGIUNGERE "LC" AL CODICE IN TABELLA.
ES: DW00444010 DIVENTA DW00444010LC

TO ORDER LEFT VERSION
ADD A "LC" IN THE CODE-CHARTS.
EXAMPLE: DW00444010 BECOMES DW00444010LC

UM DIE LINKE-VERSION ZU BESTELLEN, BEI DER
ARTIKELBEZEICHNUNG "LC" HINZUFUEGEN.
BEISPIEL: DW00444010 WIRD DANN DW00444010LC

Cod. MT	N°Utensili N°Tools N°Werkzeuge	Lubrificazione int. Coolant through Innenkuehlung	Lubrificazione est. Ext. coolant Aussenkuehlung	TAGLIA Size Masse
DW03096010	1	X	X	C6

NEW

DOOSAN BMT 85

MOD: VT900M/TM - VT1100M - PUMA 600M/LM - PUMA 700M/LM - PUMA 800M/LM

PORTAUTENSILE RADIALE SINGOLO ARRETRATO MT CAPTO

Single rear-set radial static tool MT CAPTO

Radial Single-Werkzeughalter zurueckversetzt MT CAPTO

Subject to change without notice.

M.T. srl

Via Casino Albini 480
Tel. 0541/956034-957884
Fax 0541/956341
47842 S. GIOVANNI IN M. (RN)
e-mail: mtma@mtmarchetti.com
http://www.mtmarchetti.com

PRODUZIONE MODULI ROTANTI



PAGINA DW0430-E-60

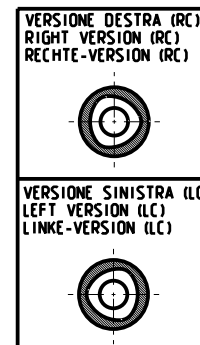
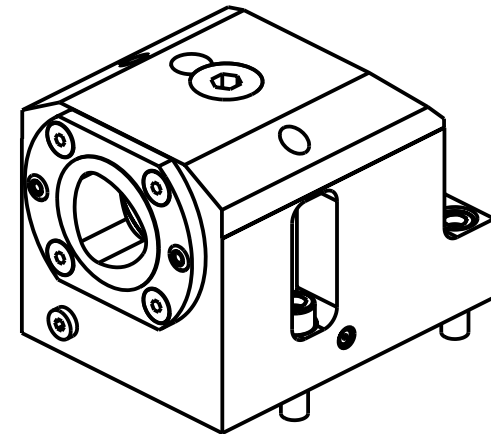
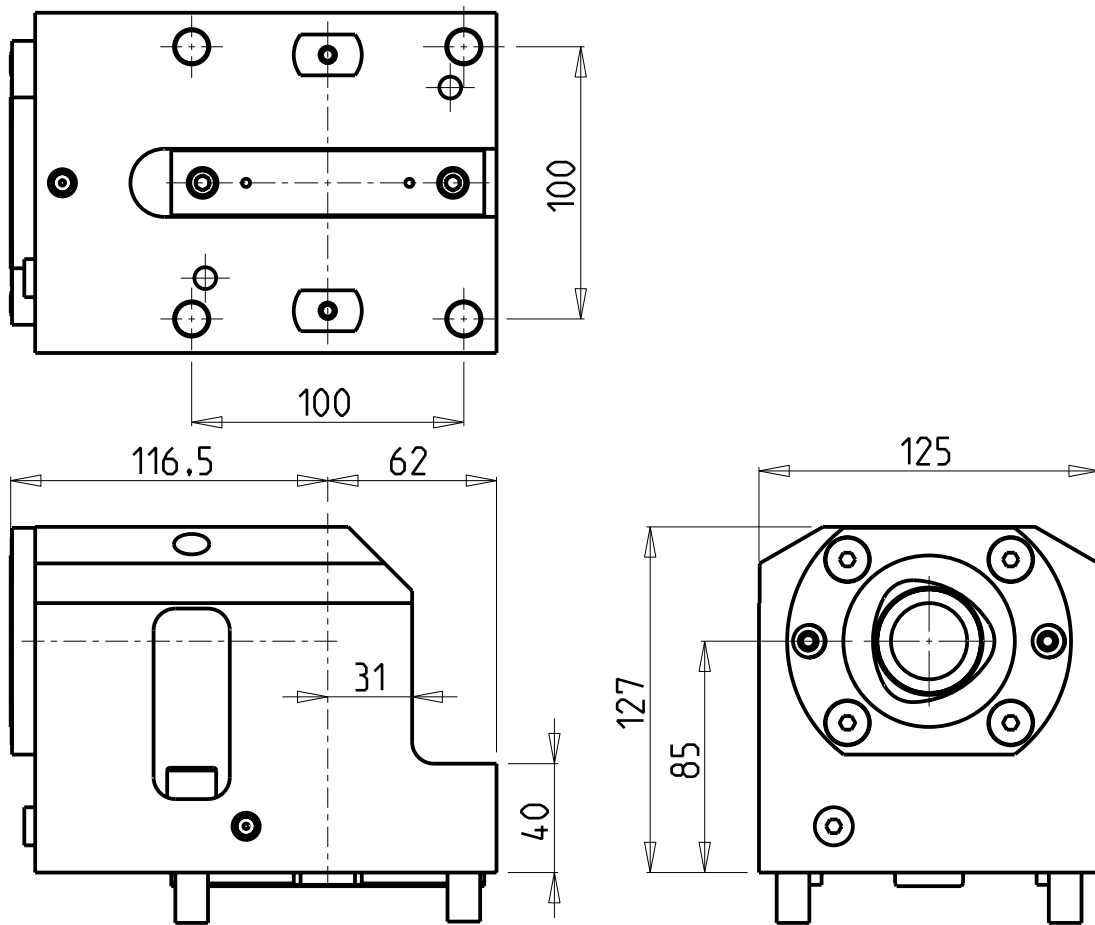

PER ORDINARE LA VERSIONE SX
AGGIUNGERE "LC" AL CODICE IN TABELLA.
ES: DW02644010 DIVENTA DW02644010LC

TO ORDER LEFT VERSION
ADD A "LC" IN THE CODE-CHARTS.
EXAMPLE: DW02644010 BECOMES DW02644010LC

UM DIE LINKE-VERSION ZU BESTELLEN, BEI DER
ARTIKELBEZEICHNUNG "LC" HINZUFUEGEN.
BEISPIEL: DW02644010 WIRD DANN DW02644010LC

Cod. MT	N°Utensili N°Tools N°Werkzeuge	Lubrificazione int. Coolant through Innenkuehlung	Reversibile lato mandrino/contromandrino Reversible sub/main spindle side Umkehrbare Spindel-seite/ Gegenspindel-seite	TAGLIA Size Masse	
DW03106010	1	X	X	C6	NEW

DOOSAN BMT 85

MOD: VT900M/TM - PUMA 600M/LM - PUMA 700M/LM - PUMA 800M/LM

PORTAUTENSILE ASSIALE SINGOLO MT CAPTO

Axial single static tool MT CAPTO

Axial Single-Werkzeughalter MT CAPTO

Subject to change without notice.

M.T. srl

Via Casino Albini 480
Tel. 0541/956034-957884
Fax 0541/956341
47842 S. GIOVANNI IN M. (RN)
e-mail: mtma@mtmarchetti.com
http://www.mtmarchetti.com

PRODUZIONE MODULI ROTANTI



PAGINA DW0550-E-60