

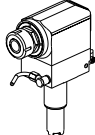

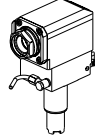

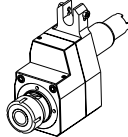

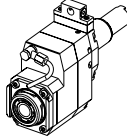

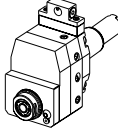

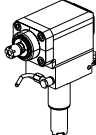
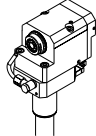



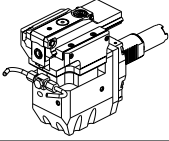

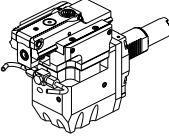

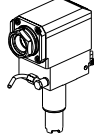
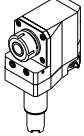
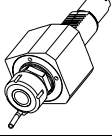
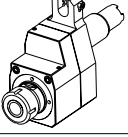
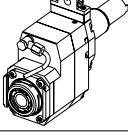
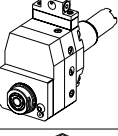
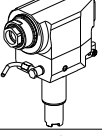
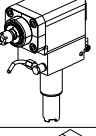
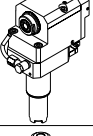
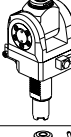

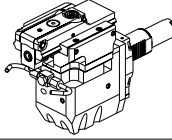
		PAGINA Page Seite
<p><b>MODULO MOTORIZZATO RADIALE VDI40</b> Radial driven tool VDI40 Radial angetriebenes Werkzeug VDI40</p>		HAS013.1.20
<p><b>MODULO MOTORIZZATO RADIALE MTSK VDI40</b> Radial MTSK driven tool VDI40 Radial MTSK angetriebenes Werkzeug VDI40</p>		HAS013.1.20.K
<p><b>MODULO MOTORIZZATO RADIALE ARRETRATO VDI40</b> Radial rear-set driven tool VDI40 Radial angetriebenes Werkzeug zurueckversetzt VDI40</p>		HAS015.1.00
<p><b>MODULO MOTORIZZATO ASSIALE VDI40</b> Axial driven tool VDI40 Axial angetriebenes Werkzeug VDI40</p>		HAS150.1.10
<p><b>MODULO MOTORIZZATO ASSIALE DISASSATO 42mm VDI40</b> Axial driven tool re-directed by 42mm VDI40 Axial angetriebenes Werkzeug achsversetzt um 42mm VDI40</p>		HAS160.1.00
<p><b>MODULO MOTORIZZ. ASSIALE MOLTIPLICATO I=1:2 DISASSATO 42mm VDI40</b> Axial geared-up I=1:2 driven tool re-directed by 42mm VDI40 Axial angetriebenes Werkzeug uebersetzt I=1:2 achsversetzt um 42mm VDI40</p>		HAS160.1.20
<p><b>MODULO MOTORIZZ. ASSIALE MOLTIPLICATO I=1:3 DISASSATO 36mm VDI40</b> Axial geared-up I=1:3 driven tool re-directed by 36mm VDI40 Axial angetriebenes Werkzeug uebersetzt I=1:3 achsversetzt um 36mm VDI40</p>		HAS160.1.30 
<p><b>MODULO MOTORIZZATO RADIALE MOLTIPLICATO I=1:2 VDI40</b> Radial geared-up I=1:2 driven tool VDI40 Radial angetriebenes Werkzeug uebersetzt I=1:2 VDI40</p>		HAS203.1.10
<p><b>MODULO MOTORIZZATO RADIALE MOLTIPLICATO I=1:3 VDI40</b> Radial geared-up I=1:3 driven tool VDI40 Radial angetriebenes Werkzeug uebersetzt I=1:3 VDI40</p>		HAS208.1.10
<p><b>MODULO MOTORIZZATO RADIALE ARRETRATO MOLTIPLICATO I=1:3 VDI40</b> Radial geared-up I=1:3 rear-set driven tool VDI40 Radial angetriebenes Werkzeug uebersetzt I=1:3 zurueckversetzt VDI40</p>		HAS226.1.10 
<p><b>MODULO MOTORIZZATO ORIENTABILE 0-90° VDI40</b> 0-90° adjustable angle driven tool VDI40 Angetriebenes Werkzeug schwenkbar 0-90° VDI40</p>		HAS330.1.00
<p><b>MODULO MOTORIZZATO ORIENTABILE ±90° CON NONIO DIGITALE VDI40</b> ±90° adjustable angle driven tool with digital display VDI40 Angetriebenes Werkzeug schwenkbar ±90° mit digital display VDI40</p>		HAS333.1.01 

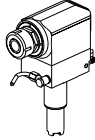
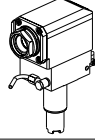
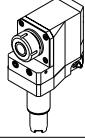
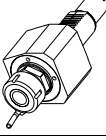
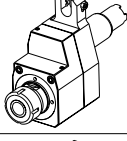
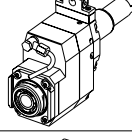
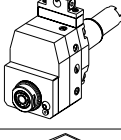
		PAGINA Page Seite
<b>MODULO MOTORIZZATO STOZZATORE CORSA 50mm VDI40</b> Slotting driven tool 50mm stroke VDI40 Keilnutenstossmaschine 50mm Hub VDI40		HAS360.1.30 
<b>MODULO MOTORIZZATO STOZZATORE CORSA 25mm VDI40</b> Slotting driven tool 25mm stroke VDI40 Keilnutenstossmaschine 25mm Hub VDI40		HAS360.1.31 

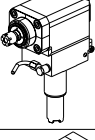
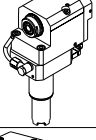
		PAGINA Page Seite
<p><b>MODULO MOTORIZZATO RADIALE VDI40</b> Radial driven tool VDI40 Radial angetriebenes Werkzeug VDI40</p>		HAS013.2.20
<p><b>MODULO MOTORIZZATO RADIALE MTSK VDI40</b> Radial MTSK driven tool VDI40 Radial MTSK angetriebenes Werkzeug VDI40</p>		HAS013.2.20.K
<p><b>MODULO MOTORIZZATO RADIALE ARRETRATO VDI40</b> Radial rear-set driven tool VDI40 Radial angetriebenes Werkzeug zurueckversetzt VDI40</p>		HAS015.2.00
<p><b>MODULO MOTORIZZATO ASSIALE VDI40</b> Axial driven tool VDI40 Axial angetriebenes Werkzeug VDI40</p>		HAS150.2.10
<p><b>MODULO MOTORIZZATO ASSIALE DISASSATO 42mm VDI40</b> Axial driven tool re-directed by 42mm VDI40 Axial angetriebenes Werkzeug achsversetzt um 42mm VDI40</p>		HAS160.2.00
<p><b>MODULO MOTORIZZ. ASSIALE MOLTIPLICATO I=1:2 DISASSATO 42mm VDI40</b> Axial geared-up I=1:2 driven tool re-directed by 42mm VDI40 Axial angetriebenes Werkzeug uebersetzt I=1:2 achsversetzt um 42mm VDI40</p>		HAS160.2.20
<p><b>MODULO MOTORIZZ. ASSIALE MOLTIPLICATO I=1:3 DISASSATO 36mm VDI40</b> Axial geared-up I=1:3 driven tool re-directed by 36mm VDI40 Axial angetriebenes Werkzeug uebersetzt I=1:3 achsversetzt um 36mm VDI40</p>		HAS160.2.30 <b>NEW</b>
<p><b>MODULO MOTORIZZATO RADIALE MOLTIPLICATO I=1:2 VDI40</b> Radial geared-up I=1:2 driven tool VDI40 Radial angetriebenes Werkzeug uebersetzt I=1:2 VDI40</p>		HAS203.2.10
<p><b>MODULO MOTORIZZATO RADIALE MOLTIPLICATO I=1:3 VDI40</b> Radial geared-up I=1:3 driven tool VDI40 Radial angetriebenes Werkzeug uebersetzt I=1:3 VDI40</p>		HAS208.2.10
<p><b>MODULO MOTORIZZATO RADIALE ARRETRATO MOLTIPLICATO I=1:3 VDI40</b> Radial geared-up I=1:3 rear-set driven tool VDI40 Radial angetriebenes Werkzeug uebersetzt I=1:3 zurueckversetzt VDI40</p>		HAS226.2.10 <b>NEW</b>
<p><b>MODULO MOTORIZZATO ORIENTABILE 0-90° VDI40</b> 0-90° adjustable angle driven tool VDI40 Angetriebenes Werkzeug schwenkbar 0-90° VDI40</p>		HAS330.2.00
<p><b>MODULO MOTORIZZATO ORIENTABILE ±90° CON NONIO DIGITALE VDI40</b> ±90° adjustable angle driven tool with digital display VDI40 Angetriebenes Werkzeug schwenkbar ±90° mit digital display VDI40</p>		HAS333.2.01 <b>NEW</b>

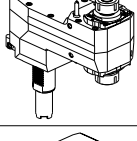
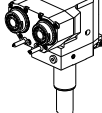
		PAGINA Page Seite
<b>MODULO MOTORIZZATO STOZZATORE CORSA 50mm VDI40</b> Slotting driven tool 50mm stroke VDI40 Keilnutenstossmaschine 50mm Hub VDI40		HAS360.2.30 
<b>MODULO MOTORIZZATO STOZZATORE CORSA 25mm VDI40</b> Slotting driven tool 25mm stroke VDI40 Keilnutenstossmaschine 25mm Hub VDI40		HAS360.2.31 

		PAGINA Page Seite
<p><b>MODULO MOTORIZZATO RADIALE VDI40</b> Radial driven tool VDI40 Radial angetriebenes Werkzeug VDI40</p>		HAS013.3.20
<p><b>MODULO MOTORIZZATO RADIALE MTSK VDI40</b> Radial MTSK driven tool VDI40 Radial MTSK angetriebenes Werkzeug VDI40</p>		HAS013.3.20.K
<p><b>MODULO MOTORIZZATO RADIALE ARRETRATO VDI40</b> Radial rear-set driven tool VDI40 Radial angetriebenes Werkzeug zurueckversetzt VDI40</p>		HAS015.3.00
<p><b>MODULO MOTORIZZATO ASSIALE VDI40</b> Axial driven tool VDI40 Axial angetriebenes Werkzeug VDI40</p>		HAS150.3.10
<p><b>MODULO MOTORIZZATO ASSIALE DISASSATO 42mm VDI40</b> Axial driven tool re-directed by 42mm VDI40 Axial angetriebenes Werkzeug achsversetzt um 42mm VDI40</p>		HAS160.3.00
<p><b>MODULO MOTORIZZ. ASSIALE MOLTIPLICATO I=1:2 DISASSATO 42mm VDI40</b> Axial geared-up I=1:2 driven tool re-directed by 42mm VDI40 Axial angetriebenes Werkzeug uebersetzt I=1:2 achsversetzt um 42mm VDI40</p>		HAS160.3.20
<p><b>MODULO MOTORIZZ. ASSIALE MOLTIPLICATO I=1:3 DISASSATO 36mm VDI40</b> Axial geared-up I=1:3 driven tool re-directed by 36mm VDI40 Axial angetriebenes Werkzeug uebersetzt I=1:3 achsversetzt um 36mm VDI40</p>		HAS160.3.30 
<p><b>MODULO MOTORIZZATO RADIALE MOLTIPLICATO I=1:2 VDI40</b> Radial geared-up I=1:2 driven tool VDI40 Radial angetriebenes Werkzeug uebersetzt I=1:2 VDI40</p>		HAS203.3.10
<p><b>MODULO MOTORIZZATO RADIALE MOLTIPLICATO I=1:3 VDI40</b> Radial geared-up I=1:3 driven tool VDI40 Radial angetriebenes Werkzeug uebersetzt I=1:3 VDI40</p>		HAS208.3.10
<p><b>MODULO MOTORIZZATO RADIALE ARRETRATO MOLTIPLICATO I=1:3 VDI40</b> Radial geared-up I=1:3 rear-set driven tool VDI40 Radial angetriebenes Werkzeug uebersetzt I=1:3 zurueckversetzt VDI40</p>		HAS226.3.10 
<p><b>MODULO MOTORIZZATO ASSIALE BISPORGENTE DISASSATO 160mm VDI40</b> Axial rear-set opposite face twin driven tool re-directed by 160mm VDI40 Axial angetriebenes Werkzeug halb vospringend achsversetzt um 160mm VDI40</p>		HAS243.3.10
<p><b>MODULO MOTORIZZATO RADIALE 2 USCITE IN Y VDI40</b> Radial single side twin head driven tool in Y VDI40 Radial angetriebenes Werkzeug 2 Ausgaenge in Y VDI40</p>		HAS263.3.10

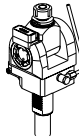
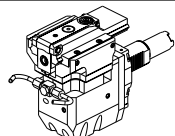
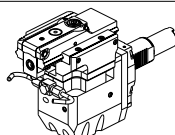
		PAGINA Page Seite
<p><b>MODULO MOTORIZZATO ORIENTABILE 0-90° VD140</b> 0-90° adjustable angle driven tool VD140 Angetriebenes Werkzeug schwenkbar 0-90° VD140</p>		HAS330.3.00
<p><b>MODULO MOTORIZZATO ORIENTABILE ±90° CON NONIO DIGITALE VD140</b> ±90° adjustable angle driven tool with digital display VD140 Angetriebenes Werkzeug schwenkbar ±90° mit digital display VD140</p>		HAS333.3.01 NEW
<p><b>MODULO MOTORIZZATO STOZZATORE CORSA 50mm VD140</b> Slotting driven tool 50mm stroke VD140 Keilnutenstossmaschine 50mm Hub VD140</p>		HAS360.3.30 NEW
<p><b>MODULO MOTORIZZATO STOZZATORE CORSA 25mm VD140</b> Slotting driven tool 25mm stroke VD140 Keilnutenstossmaschine 25mm Hub VD140</p>		HAS360.3.31 NEW

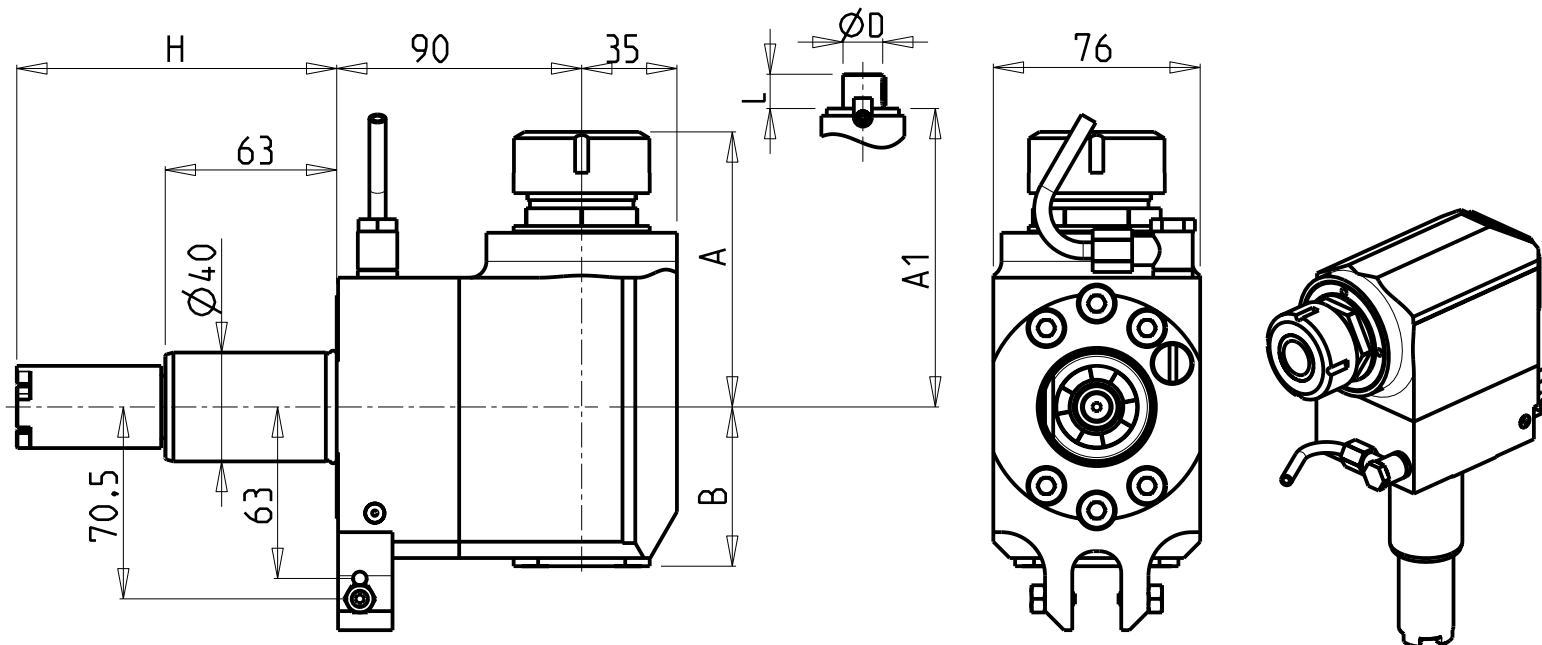

### ATTENZIONE - ATTENTION - ACHTUNG

- Per lo smontaggio degli utensili utilizzare sempre la chiave di contrasto come indicato nel manuale d'uso.
- For disassembly of the tools use always the contrast key as mentioned in the user instructions.
- Fuer das Abmontieren der Werkzeuge immer den Gegenschlüssel benutzen wie in der Bedienungsanleitung erwäehnt.

- Chiave inclusa
- Key included
- Schlüssel inbegriffen

Cod. MT	Mandrino Spindle Spindel	I	RPM	Coppia Max Max Torque Max Drehmoment	Lubrificazione int. Coolant through Innenkuhlung	Lubrificazione est. Ext. coolant Aussenkuhlung	A	A1	B	H	Tipo Torretta Turret type Revolver typ	CHIAVI NON INCLUSE Keys not included Schlüssel nicht inbegriffen	
HAS0130132	ER32	1:1	6000	70Nm		X	101.1	-	58.5	104.85	VDI STANDARD	CHUB41	CHSTER32
HAS0130232	ER32	1:1	6000	70Nm	P=70bar	X	101.1	-	82	104.85	VDI STANDARD	CHUB41	CHSTER32
HAS0132219	Ø22x19	1:1	6000	70Nm		X	-	78.5	58.5	104.85	VDI STANDARD	CHUB41	CH_VTCROCE_M10 •
HAS0132721	Ø27x21	1:1	6000	70Nm		X	-	78.5	58.5	104.85	VDI STANDARD	CHUB41	CH_VTCROCE_M12 •
HAS0140132	ER32	1:1	6000	70Nm		X	101.1	-	58.5	117.55	HYBRID 12 TURRET	CHUB41	CHSTER32
HAS0140232	ER32	1:1	6000	70Nm	P=70bar	X	101.1	-	82	117.55	HYBRID 12 TURRET	CHUB41	CHSTER32
HAS0142219	Ø22x19	1:1	6000	70Nm		X	-	78.5	58.5	117.55	HYBRID 12 TURRET	CHUB41	CH_VTCROCE_M10 •
HAS0142721	Ø27x21	1:1	6000	70Nm		X	-	78.5	58.5	117.55	HYBRID 12 TURRET	CHUB41	CH_VTCROCE_M12 •

HAAS

MOD: SL10/20/30

MODULO MOTORIZZATO RADIALE VD140

Radial driven tool VD140

Radial angetriebenes Werkzeug VD140

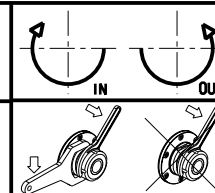

**M.T. srl**

Via Casino Albini 480  
Tel. 0541/956034-957884

Fax 0541/956341

47842 S. GIOVANNI IN M. (RN)

e-mail: mtma@mtmarchetti.com

http://www.mtmarchetti.com

PRODUZIONE MODULI ROTANTI



PAGINA HAS013-1-20

**ATTENZIONE - ATTENTION - ACHTUNG**

- Per lo smontaggio degli utensili utilizzare sempre la chiave di contrasto come indicato nel manuale d'uso.
- For disassembly of the tools use always the contrast key as mentioned in the user instructions.
- Fuer das Abmontieren der Werkzeuge immer den Gegenschlüssel benutzen wie in der Bedienungsanleitung erwahnt.

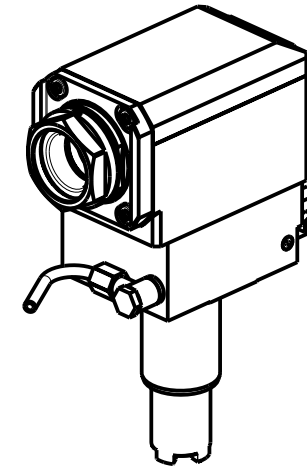
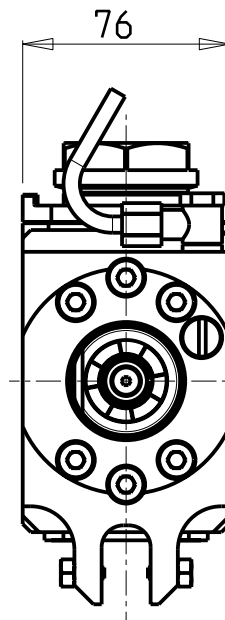
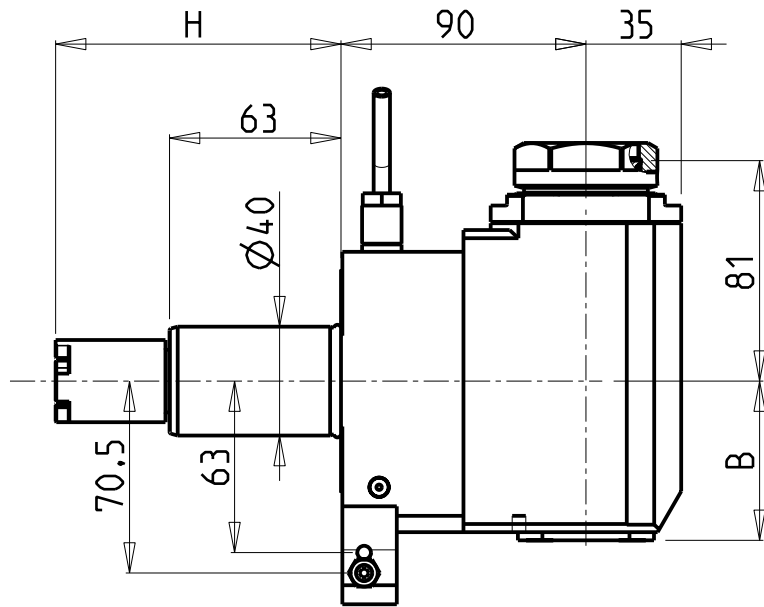

PER PORTAUTENSILI MODULARI MTSK-40 VEDI PAG. TBL300-1-40  
 FOR MTSK-40 QUICK CHANGE TOOLHOLDERS CLAMPINGS SEE PAGE TBL300-1-40  
 FUER MTSK-40 MODULARE WERKZEUGAUFNAHMEN SIEHE SEITE TBL300-1-40

- Chiave inclusa
- Key included
- Schlüssel inbegriffen

Cod. MT	Mandrino Spindle Spindel	I	RPM	Coppia Max Max Torque Max Drehmoment	Lubrificazione int. Coolant through Innenkuehlung	Lubrificazione est. Ext. coolant Aussenkuehlung	B	H	Tipo Torretta Turret type Revolver typ	CHIAVI NON INCLUSE Keys not included Schluessel nicht einbegriffen	
										C	K
HAS0270140	MTSK-40	1:1	6000	70Nm	-	X	58.5	104.85	VDI STANDARD	C HUB46	OKU0650004 •
HAS0270240	MTSK-40	1:1	6000	70Nm	P=70bar	X	69.5	104.85	VDI STANDARD	C HUB46	OKU0650004 •
HAS0280140	MTSK-40	1:1	6000	70Nm	-	X	58.5	117.55	HYBRID 12 TURRET	C HUB46	OKU0650004 •
HAS0280240	MTSK-40	1:1	6000	70Nm	P=70bar	X	69.5	117.55	HYBRID 12 TURRET	C HUB46	OKU0650004 •

HAAS

MOD: SL10/20/30

MODULO MOTORIZZATO RADIALE MTSK VDI40  
 Radial MTSK driven tool VDI40  
 Radial MTSK angetriebenes Werkzeug VDI40

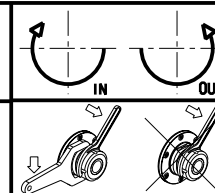

**M.T. srl**

Via Casino Albini 480  
 Tel. 0541/956034-957884  
 Fax 0541/956341  
 47842 S. GIOVANNI IN M. (RN)  
 e-mail: mtma@mtmarchetti.com  
 http://www.mtmarchetti.com

PRODUZIONE MODULI ROTANTI



PAGINA HAS013-1-20-K



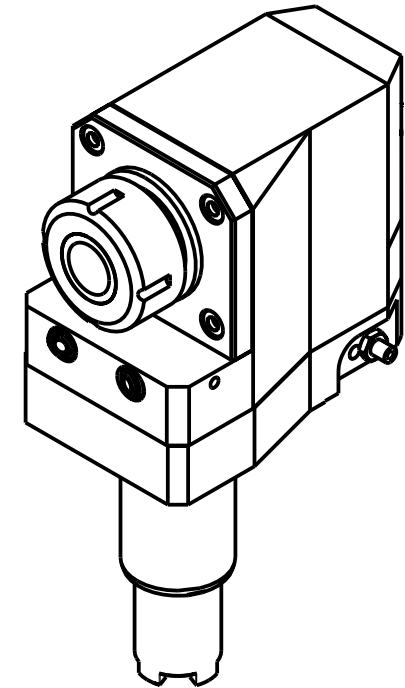
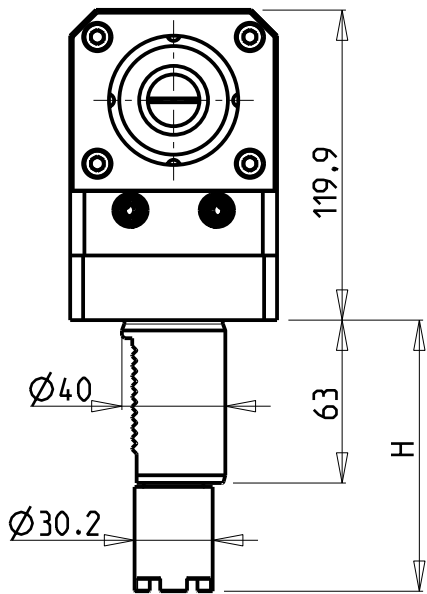
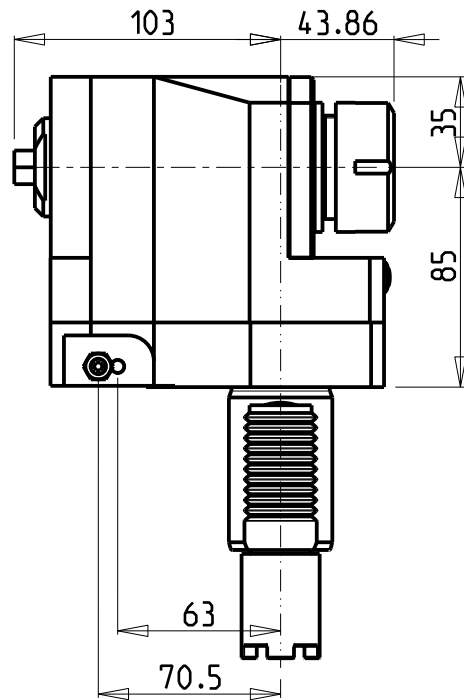
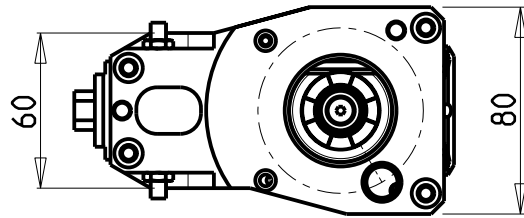

Cod. MT	Mandrino Spindle Spindel	I	RPM	Coppia Max Max Torque Max Drehmoment	Lubrificazione est. Ext. coolant Ausseukuehlung	H	Tipo Torretta Turret Type Revolver Typ	CHIAVI NON INCLUSE Keys not included Schluessel nicht einbegriffen	
HAS0030232	ER32	1:1	6000	70Nm	X	104.85	VDI STANDARD	CHUB13	CHSTER32
HAS0040232	ER32	1:1	6000	70Nm	X	117.55	HYBRID 12 TURRET	CHUB13	CHSTER32

HAAS  
MOD: SL10/20/30

MODULO MOTORIZZATO RADIALE ARRETRATO VDI40  
Radial rear-set driven tool VDI40  
Radial angetriebenes Werkzeug zurueckversetzt VDI40

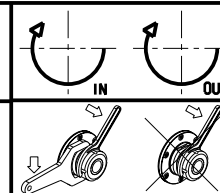

**M.T. srl**  
Via Casino Albini 480  
Tel. 0541/956034-957884  
Fax 0541/956341  
47842 S. GIOVANNI IN M. (RN)  
e-mail: mtma@mtmarchetti.com  
http://www.mtmarchetti.com

PRODUZIONE MODULI ROTANTI



PAGINA HAS015-1-00

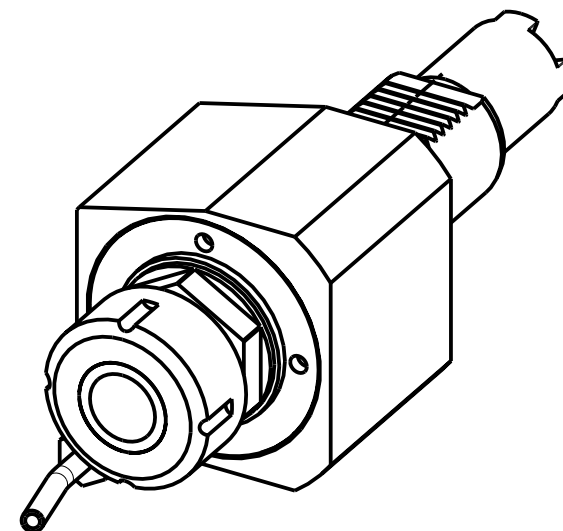
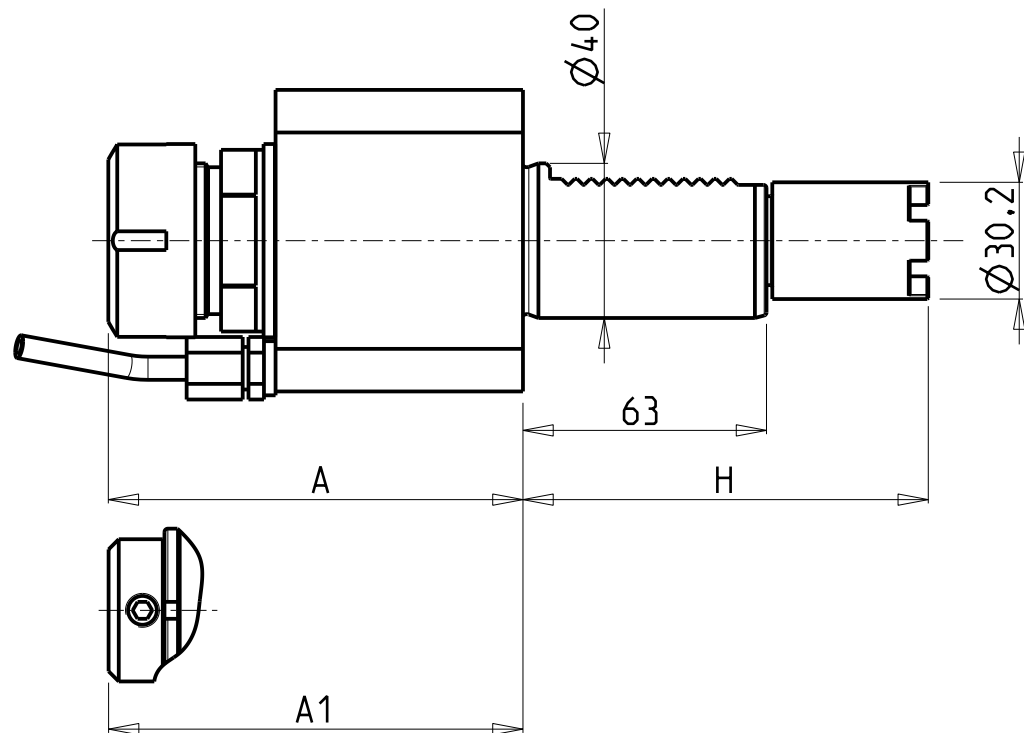
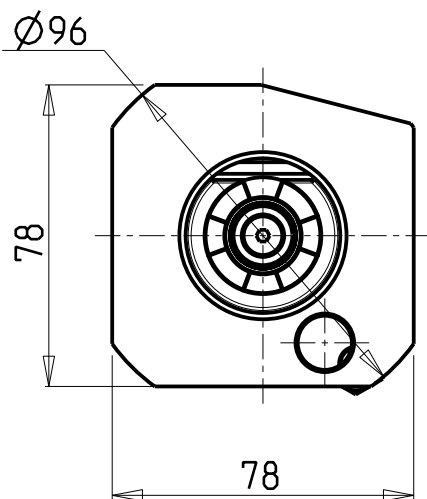

Cod. MT	Mandrino Spindle Spindel	I	RPM	Coppia Max Max Torque Max Drehmoment	Lubrificazione est. Ext. coolant Aussenkuhlung	Lubrificazione int. Coolant through Innenkuehlung	A	A1	H	Tipo Torretta Turret Type Revolver Typ	CHIAVI NON INCLUSE Keys not included Schluessel nicht einbegriffen	
											CHUB41	CHSTER32
HAS0010232	ER32	1:1	6000	70Nm	X	-	107.26	-	104.85	VDI STANDARD	CHUB41	CHSTER32
HAS0010132	ER32	1:1	6000	70Nm	X	P=30bar	110.46	-	104.85	VDI STANDARD	CHUB41	CHSTER32
HAS0010525	WELDON25	1:1	6000	70Nm	X	-	-	97.1	104.85	VDI STANDARD	-	-
HAS0020232	ER32	1:1	6000	70Nm	X	-	107.26	-	117.55	HYBRID 12 TURRET	CHUB41	CHSTER32
HAS0020132	ER32	1:1	6000	70Nm	X	P=30bar	110.46	-	117.55	HYBRID 12 TURRET	CHUB41	CHSTER32
HAS0020525	WELDON25	1:1	6000	70Nm	X	-	-	97.1	117.55	HYBRID 12 TURRET	-	-

HAAS

MOD: SL10/20/30

MODULO MOTORIZZATO ASSIALE VDI40

Axial driven tool VDI40

Axial angetriebenes Werkzeug VDI40

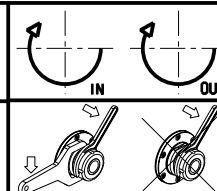

**M.T. srl**

Via Casino Albini 480  
Tel. 0541/956034-957884  
Fax 0541/956341

47842 S. GIOVANNI IN M. (RN)  
e-mail: mtma@mtmarchetti.com  
http://www.mtmarchetti.com

PRODUZIONE MODULI ROTANTI



PAGINA HAS150-1-10

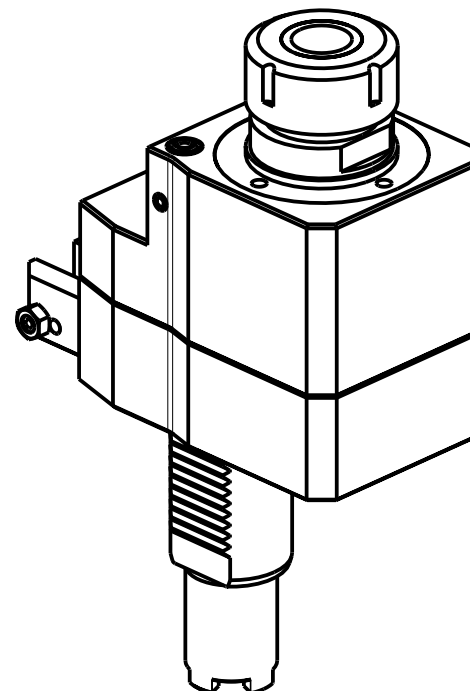
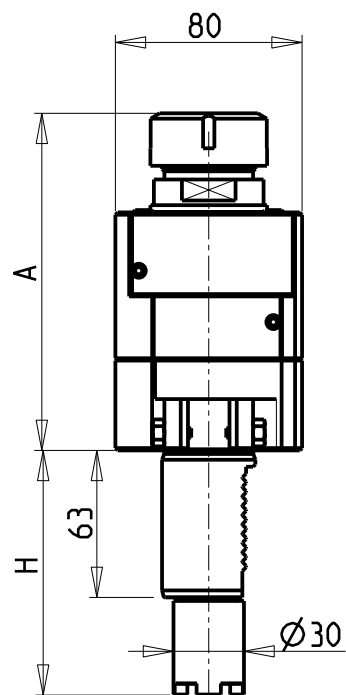
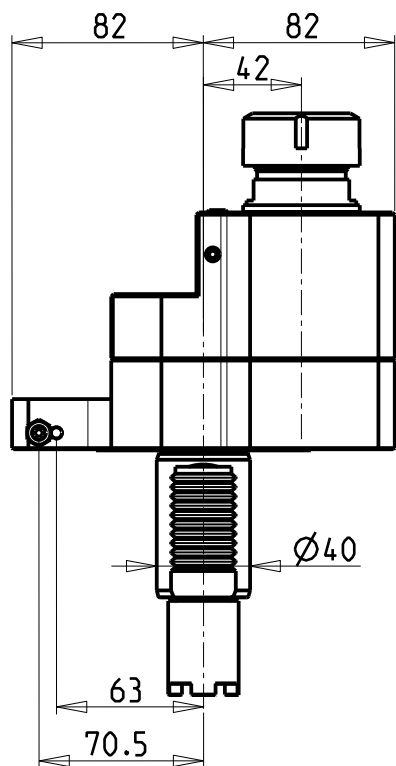

Cod. MT	Mandrino Spindle Spindel	I	RPM	Coppia Max Max Torque Max Drehmoment	Lubrificazione int. Coolant through Innenkühlung	Lubrificazione est. Ext. coolant Aussenkühlung	A	H	Tipo Torretta Turret Type Revolver Typ	CHIAVI NON INCLUSE Keys not included Schlüssel nicht einbegriffen	
HAS0070032	ER32	1:1	6000	70Nm		X	144.66	104.85	VDI STANDARD	CHUB41	CHSTER32
HAS0071132	ER32	1:1	6000	70Nm	P=30bar		164.96	104.85	VDI STANDARD	CHUB38	CHSTER32
HAS0072132	ER32	2:1	3000	100Nm		X	144.66	104.85	VDI STANDARD	CHUB41	CHSTER32
HAS0074232	ER32	2:1	3000	100Nm	P=30bar		164.96	104.85	VDI STANDARD	CHUB38	CHSTER32
HAS0080032	ER32	1:1	6000	70Nm		X	144.66	117.55	HYBRID 12 TURRET	CHUB41	CHSTER32
HAS0081132	ER32	1:1	6000	70Nm	P=30bar		164.96	117.55	HYBRID 12 TURRET	CHUB38	CHSTER32
HAS0082132	ER32	2:1	3000	100Nm		X	144.66	117.55	HYBRID 12 TURRET	CHUB41	CHSTER32
HAS0084232	ER32	2:1	3000	100Nm	P=30bar		164.96	117.55	HYBRID 12 TURRET	CHUB38	CHSTER32

HAAS

MOD: SL10/20/30

MODULO MOTORIZZATO ASSIALE DISASSATO 42mm VDI40

Axial driven tool re-directed by 42mm VDI40

Axial angetriebenes Werkzeug achsversetzt um 42mm VDI40

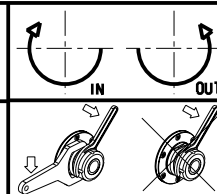

**M.T. srl**

Via Casino Albini 480  
Tel. 0541/956034-957884  
Fax 0541/956341

47842 S. GIOVANNI IN M. (RN)  
e-mail: mtma@mtmarchetti.com  
http://www.mtmarchetti.com

PRODUZIONE MODULI ROTANTI



PAGINA HAS160-1-00

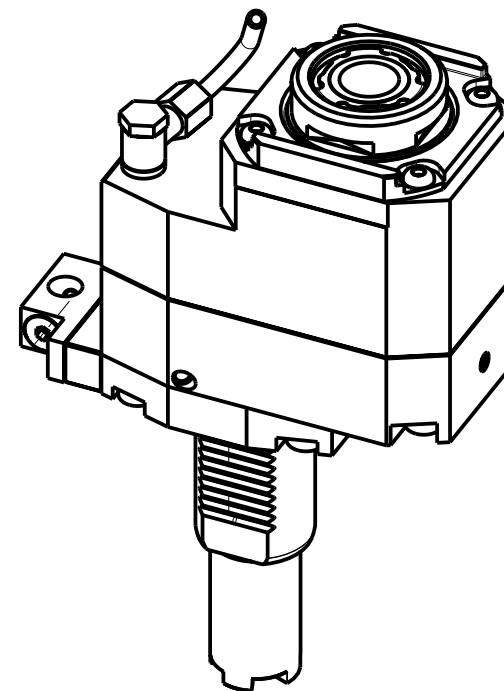
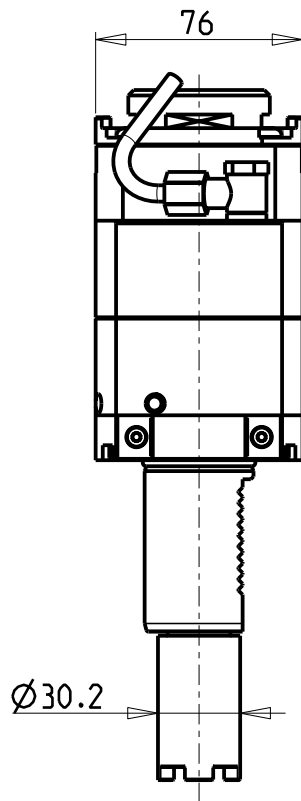
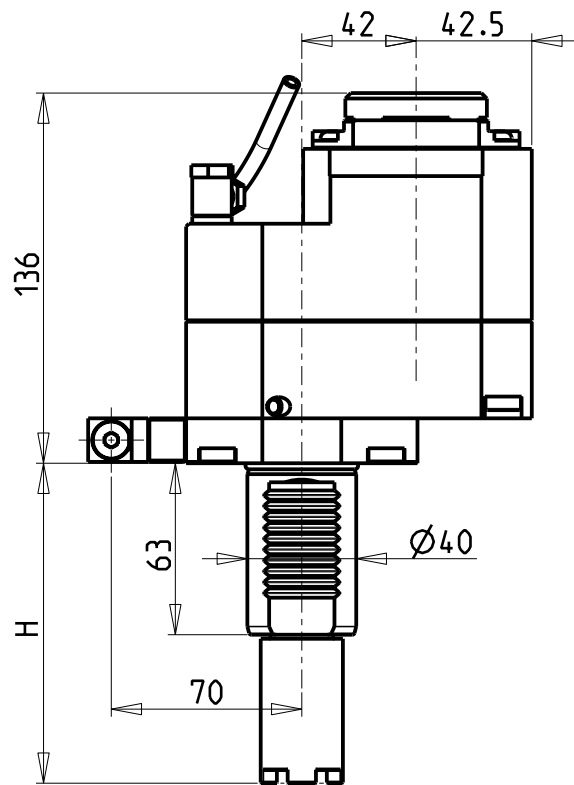

- Chiave inclusa
- Key included
- Schluessel inbegriffen

Cod. MT	Mandrino Spindle Spindel	I	RPM	Coppia Max Max Torque Max Drehmoment	Lubrificazione int. Coolant through Innenkuhlung	Lubrificazione est. Ext. coolant Aussenkuhlung	H	Tipo Torretta Turret Type Revolver Typ	CHIAVI NON INCLUSE Keys not included Schluessel nicht einbegriffen		
HAS0307132	ERA32	1:2	12000	45Nm	-	X	104.85	VDI STANDARD	C HUB30	CHTAER32ZC	OKU0650004
HAS0307232	ERA32	1:2	12000	45Nm	P=30bar	X	104.85	VDI STANDARD	C HUB30	CHTAER32ZC	OKU0650004
HAS0317132	ERA32	1:2	12000	45Nm	-	X	117.55	HYBRID 12 TURRET	C HUB30	CHTAER32ZC	OKU0650004
HAS0317232	ERA32	1:2	12000	45Nm	P=30bar	X	117.55	HYBRID 12 TURRET	C HUB30	CHTAER32ZC	OKU0650004

HAAS

MOD: SL10/20/30

MODULO MOTORIZZATO ASSIALE MOLTIPLICATO I=1:2 DISASSATO 42mm VDI40

Axial geared-up I=1:2 driven tool re-directed by 42mm VDI40

Axial angetriebenes Werkzeug uebersetzt I=1:2 achsversetzt um 42mm VDI40

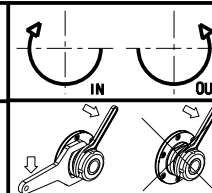

**M.T. srl**

Via Casino Albini 480  
Tel. 0541/956034-957884  
Fax 0541/956341

47842 S. GIOVANNI IN M. (RN)  
e-mail: mtma@mtmarchetti.com  
http://www.mtmarchetti.com

PRODUZIONE MODULI ROTANTI



PAGINA HAS160-1-20

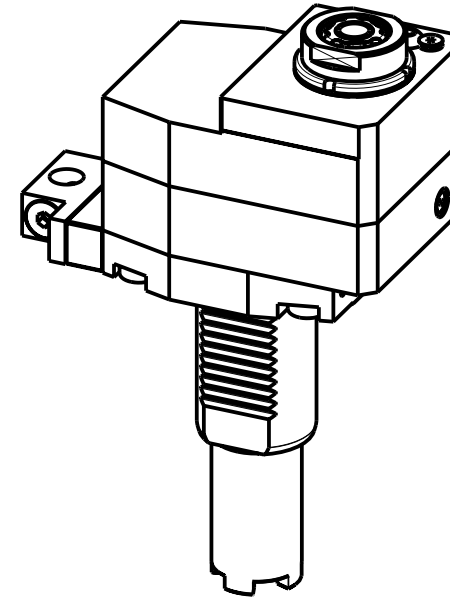
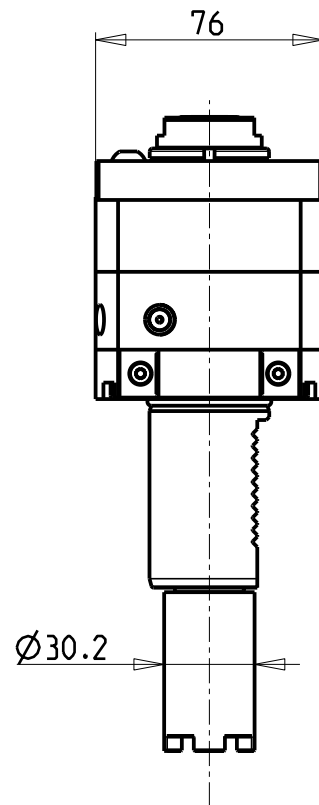
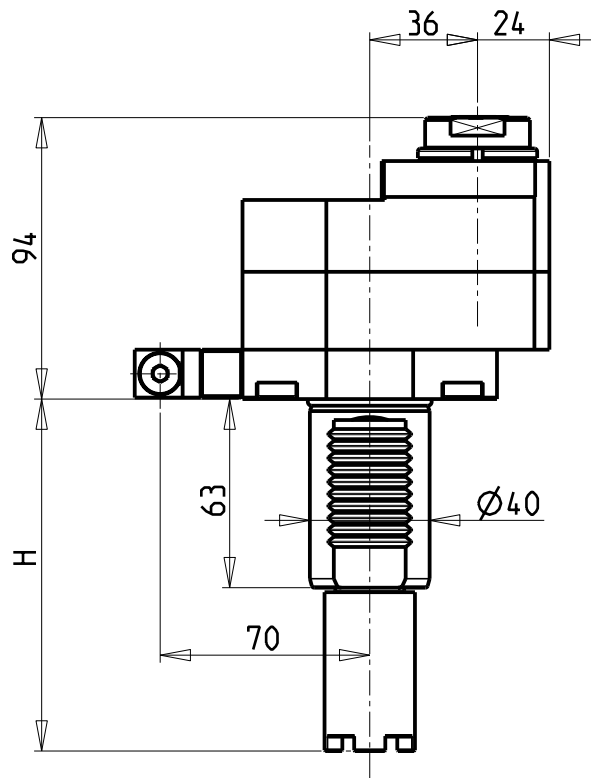

- Chiave inclusa
- Key included
- Schlüssel inbegriffen

Cod. MT	Mandrino Spindle Spindel	I	RPM	Coppia Max Max Torque Max Drehmoment	Lubrificazione int. Coolant through Innenkühlung	Lubrificazione est. Ext. coolant Aussenkühlung	H	Tipo Torretta Turret Type Revolver Typ	CHIAVI NON INCLUSE Keys not included Schlüssel nicht einbegriffen			
HAS0390116	ERA16	1:3	18000	10Nm	-	X	104.85	VDI STANDARD	C HUB30	C HUB19_SP3	C HTAER16ZC	NEW
HAS0390216	ERA16	1:3	18000	10Nm	P=30bar	X	104.85	VDI STANDARD	C HUB30	C HUB19_SP3	C HTAER16ZC	NEW
HAS0380116	ERA16	1:3	18000	10Nm	-	X	117.55	HYBRID 12 TURRET	C HUB30	C HUB19_SP3	C HTAER16ZC	NEW
HAS0380216	ERA16	1:3	18000	10Nm	P=30bar	X	117.55	HYBRID 12 TURRET	C HUB30	C HUB19_SP3	C HTAER16ZC	NEW

HAAS

MOD: SL10/20/30

MODULO MOTORIZZATO ASSIALE MOLTIPLICATO I=1:3 DISASSATO 36mm VDI40

Axial geared-up I=1:3 driven tool re-directed by 36mm VDI40

Axial angetriebenes Werkzeug uebersetzt I=1:3 achsversetzt um 36mm VDI40

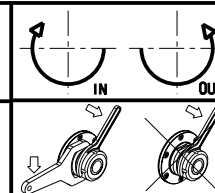

**M.T. srl**

Via Casino Albini 480  
Tel. 0541/956034-957884

Fax 0541/956341

47842 S. GIOVANNI IN M. (RN)

e-mail: mtma@mtmarchetti.com

http://www.mtmarchetti.com

PRODUZIONE MODULI ROTANTI



PAGINA HAS160-1-30

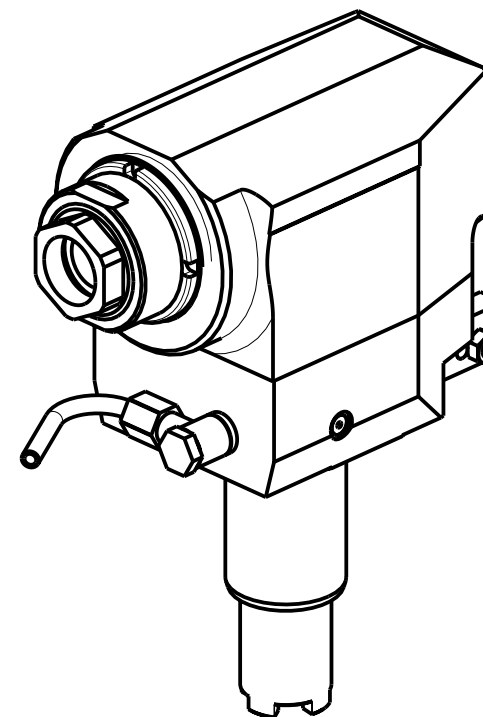
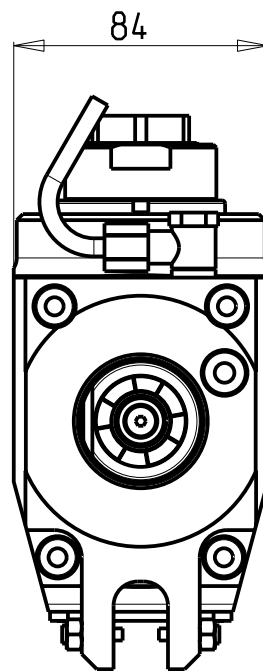
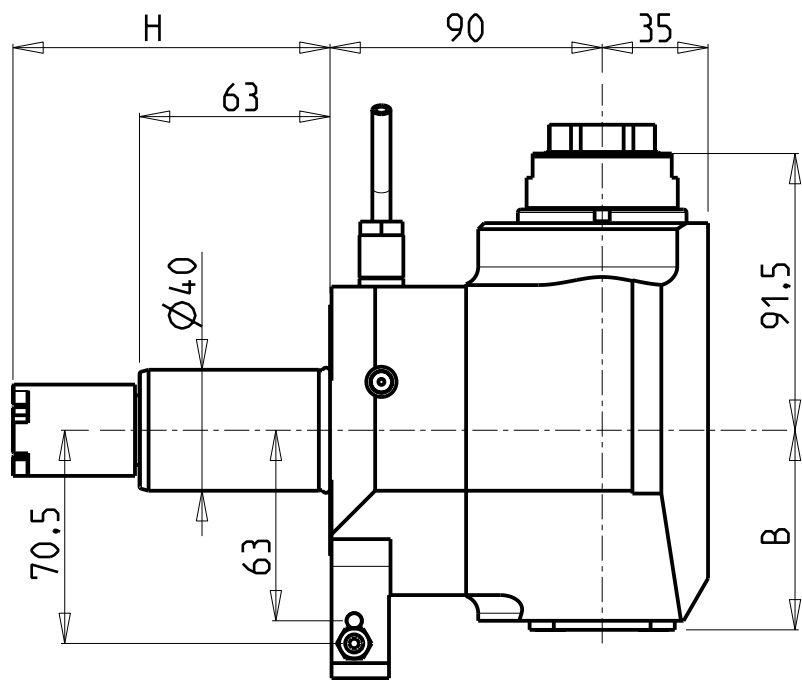

Cod. MT	Mandrino Spindle Spindel	I	RPM	Coppia Max Max Torque Max Drehmoment	Lubrificazione int. Coolant through Innenkühlung	Lubrificazione est. Ext. coolant Aussenkühlung	B	H	Tipo Torretta Turret type Revolver typ	CHIAVI NON INCLUSE Keys not included Schlüssel nicht einbegriffen	
										CHUB41	CHUB32
HAS0150132	ERA32	1:2	12000	30Nm		X	66	104.85	VDI STANDARD	CHUB41	CHUB32
HAS0150232	ERA32	1:2	12000	30Nm	P=70bar	X	76	104.85	VDI STANDARD	CHUB41	CHUB32
HAS0160132	ERA32	1:2	12000	30Nm		X	66	117.55	HYBRID 12 TURRET	CHUB41	CHUB32
HAS0160232	ERA32	1:2	12000	30Nm	P=70bar	X	76	117.55	HYBRID 12 TURRET	CHUB41	CHUB32

HAAS  
MOD: SL10/20/30

MODULO MOTORIZZATO RADIALE MOLTIPLICATO I=1:2 VDI40  
Radial geared-up I=1:2 driven tool VDI40  
Radial angetriebenes Werkzeug uebersezt I=1:2 VDI40

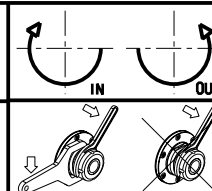

**M.T. srl**  
Via Casino Albini 480  
Tel. 0541/956034-957884  
Fax 0541/956341  
47842 S. GIOVANNI IN M. (RN)  
e-mail: mtma@mtmarchetti.com  
http://www.mtmarchetti.com

PRODUZIONE MODULI ROTANTI



PAGINA HAS203-1-10

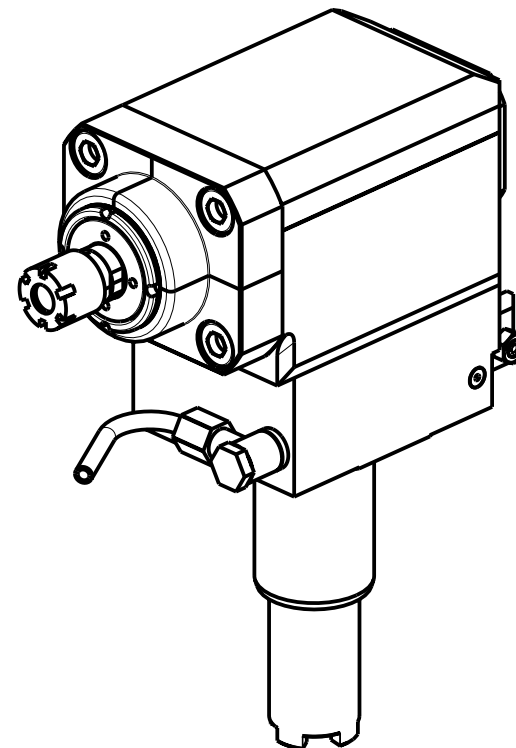
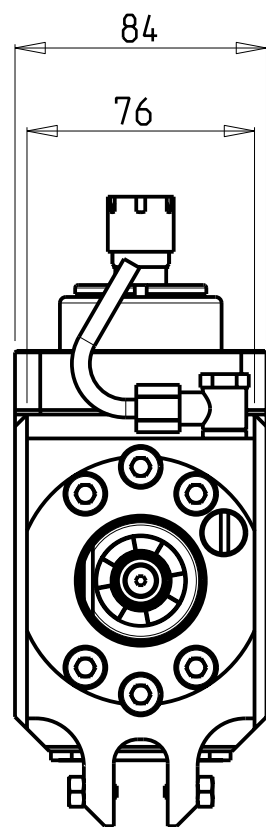
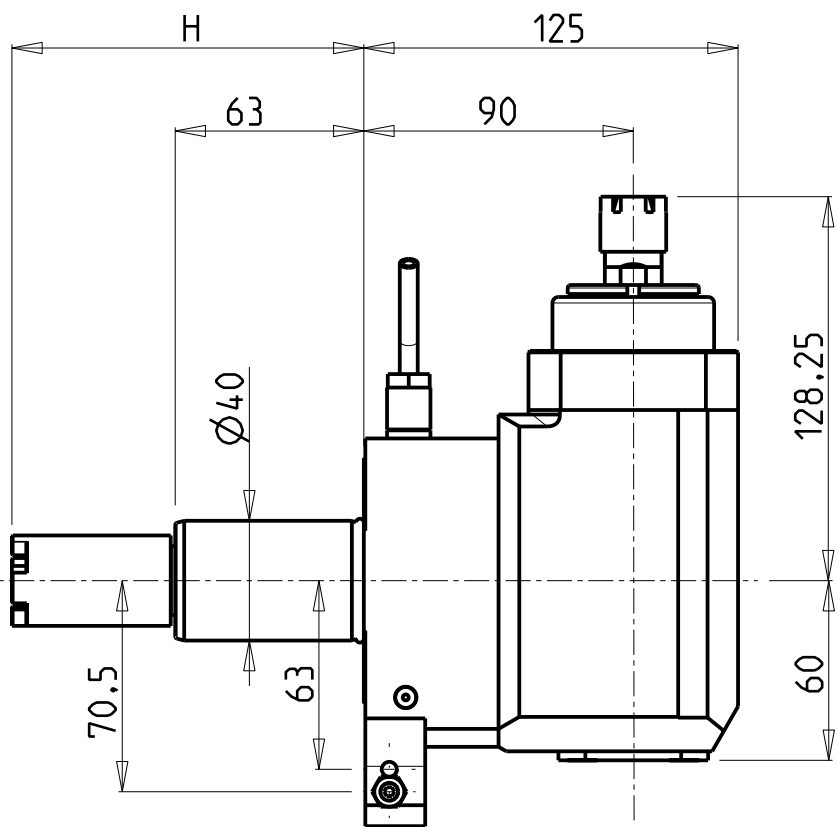

Cod. MT	Mandrino Spindle Spindel	I	RPM	Coppia Max Max Torque Max Drehmoment	Lubrificazione est. Ext. coolant Aussenkühlung	H	Tipo Torretta Turret type Revolver typ	CHIAVI INCLUSE Keys included Schlüssel einbegriffen	
HAS0330016	ER16	1:3	18000	10Nm	X	104.85	VDI STANDARD	CHUB17	CHMNER16
HAS0340016	ER16	1:3	18000	10Nm	X	117.55	HYBRID 12 TURRET	CHUB17	CHMNER16

HAAS  
MOD: SL10/20/30

MODULO MOTORIZZATO RADIALE MOLTIPLICATO I=1:3 VDI40  
Radial geared-up I=1:3 driven tool VDI40  
Radial angetriebenes Werkzeug uebersezt I=1:3 VDI40

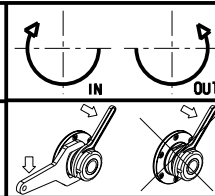

**M.T. srl**  
Via Casino Albini 480  
Tel. 0541/956034-957884  
Fax 0541/956341  
47842 S. GIOVANNI IN M. (RN)  
e-mail: mtma@mtmarchetti.com  
http://www.mtmarchetti.com

PRODUZIONE MODULI ROTANTI



PAGINA HAS208-1-10

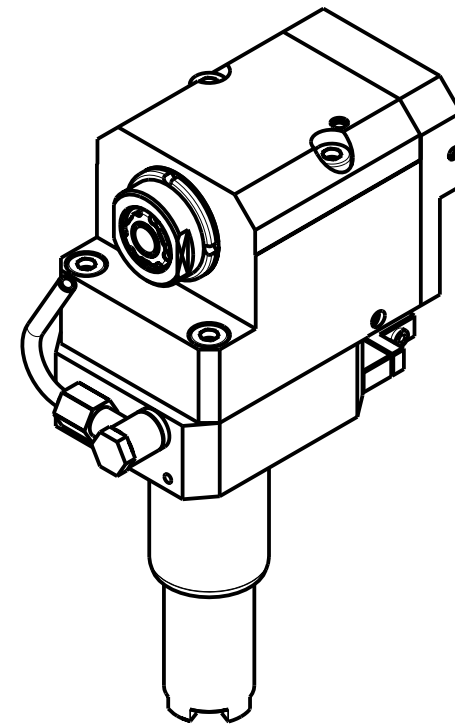
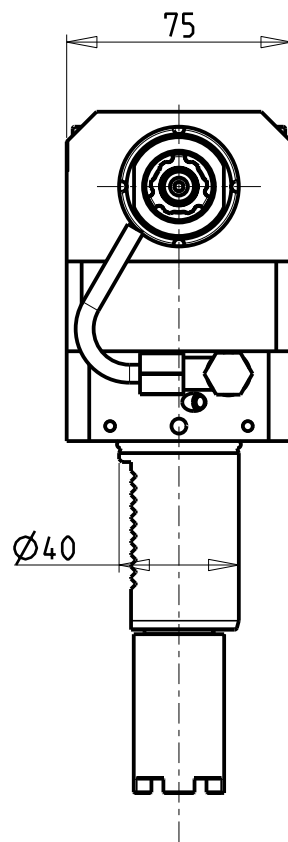
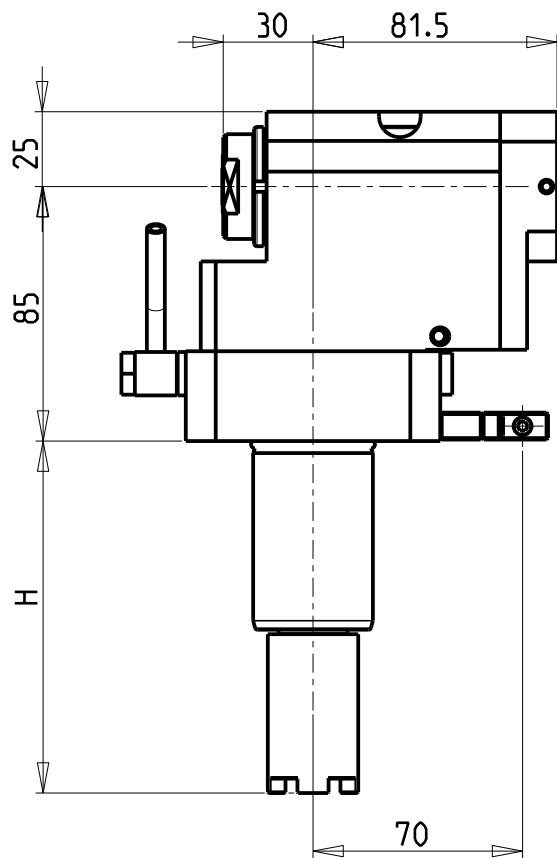

- Chiave inclusa
- Key included
- Schlüssel inbegriffen

Cod. MT	Mandrino Spindle Spindel	I	RPM	Coppia Max Max Torque Max Drehmoment	Lubrificazione int. Coolant through Innenkühlung	Lubrificazione est. Ext. coolant AusSENKühlung	H	Tipo Torretta Turret Type Revolver Typ	CHIAVI NON INCLUSE Keys not included Schlüssel nicht einbegriffen			
									C HUB30	C HUB19_SP3	C HTAER16ZC	
HAS0420116	ERA16	1:3	18000	10Nm	-	X	104.85	VDI STANDARD	C HUB30	C HUB19_SP3	C HTAER16ZC	• NEW
HAS0420216	ERA16	1:3	18000	10Nm	P=70bar	X	104.85	VDI STANDARD	C HUB30	C HUB19_SP3	C HTAER16ZC	• NEW
HAS0410116	ERA16	1:3	18000	10Nm	-	X	117.55	HYBRID 12 TURRET	C HUB30	C HUB19_SP3	C HTAER16ZC	• NEW
HAS0410216	ERA16	1:3	18000	10Nm	P=70bar	X	117.55	HYBRID 12 TURRET	C HUB30	C HUB19_SP3	C HTAER16ZC	• NEW

HAAS

MOD: SL10/20/30

MODULO MOTORIZZATO RADIALE ARRETRATO MOLTIPLICATO I=1:3 VDI40

Radial geared-up I=1:3 rear-set driven tool VDI40

Radial angetriebenes Werkzeug uebersezt I=1:3 zurueckversetzt VDI40

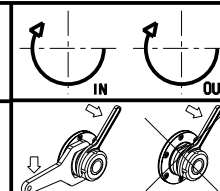

**M.T. srl**

Via Casino Albini 480  
Tel. 0541/956034-957884

Fax 0541/956341

47842 S. GIOVANNI IN M. (RN)

e-mail: mtma@mtmarchetti.com

http://www.mtmarchetti.com

PRODUZIONE MODULI ROTANTI



PAGINA HAS226-1-10



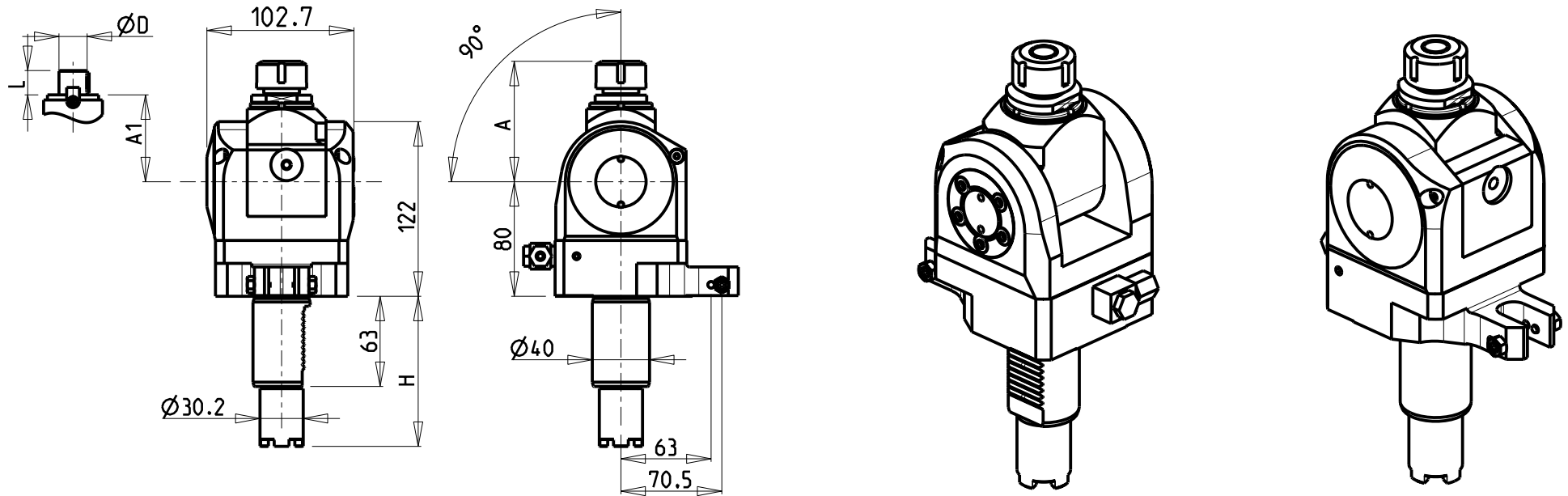

Cod. MT	Mandrino Spindle Spindel	I	RPM	Coppia Max Max Torque Max Drehmoment	Lubrificazione est. Ext. coolant Aussekkuehlung	A	A1	D	L	H	Tipo Torretta Turret Type Revolver Typ	CHIAVI INCLUSE Keys included Schluessel inbegriffen	
HAS0050020	ER20	1:1	6000	40Nm	X	84.16	-	-	-	104.85	VDI STANDARD	CHUB36	CHSTER20
HAS0060020	ER20	1:1	6000	40Nm	X	84.16	-	-	-	117.55	HYBRID 12 TURRET	CHUB36	CHSTER20
HAS0050025	ER25	1:1	6000	40Nm	X	85.66	-	-	-	104.85	VDI STANDARD	CHUB36	CHSTER25
HAS0060025	ER25	1:1	6000	40Nm	X	85.66	-	-	-	117.55	HYBRID 12 TURRET	CHUB36	CHSTER25
HAS0051617	Ø16x17	1:1	6000	40Nm	X	-	65	16	17	104.85	VDI STANDARD	CHUB36	CH_VTCROCE_M08
HAS0061617	Ø16x17	1:1	6000	40Nm	X	-	65	16	17	117.55	HYBRID 12 TURRET	CHUB36	CH_VTCROCE_M08
HAS0052219	Ø22x19	1:1	6000	40Nm	X	-	66	22	19	104.85	VDI STANDARD	CHUB36	CH_VTCROCE_M10
HAS0062219	Ø22x19	1:1	6000	40Nm	X	-	66	22	22	117.55	HYBRID 12 TURRET	CHUB36	CH_VTCROCE_M10
HAS0051905	Ø3/4"x3/4"	1:1	6000	40Nm	X	-	65	3/4"	3/4"	104.85	VDI STANDARD	CHUB36	CH_VTCROCE_M08
HAS0061905	Ø3/4"x3/4"	1:1	6000	40Nm	X	-	65	3/4"	3/4"	117.55	HYBRID 12 TURRET	CHUB36	CH_VTCROCE_M08

HAAS

MOD: SL10/20/30

MODULO MOTORIZZATO ORIENTABILE 0-90° VDI40

0-90° adjustable angle driven tool VDI40

Angetriebenes Werkzeug schwenkbar 0-90° VDI40

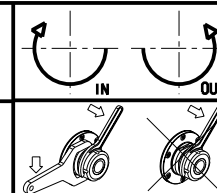

**M.T. srl**

Via Casino Albini 480  
Tel. 0541/956034-957884

Fax 0541/956341

47842 S. GIOVANNI IN M. (RN)

e-mail: mtma@mtmarchetti.com

http://www.mtmarchetti.com

PRODUZIONE MODULI ROTANTI



PAGINA HAS330-1-00

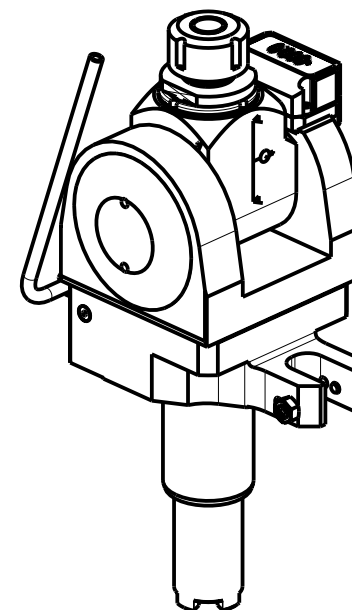
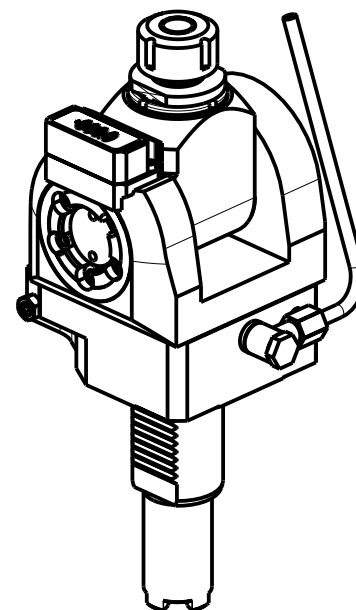
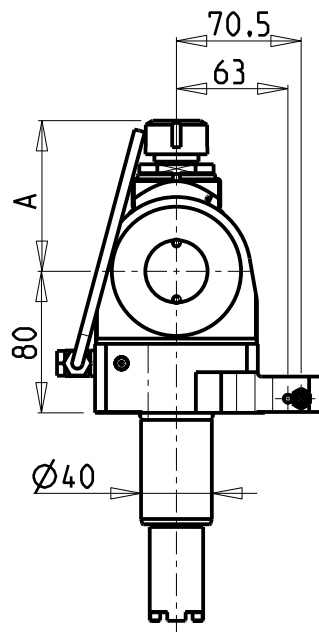
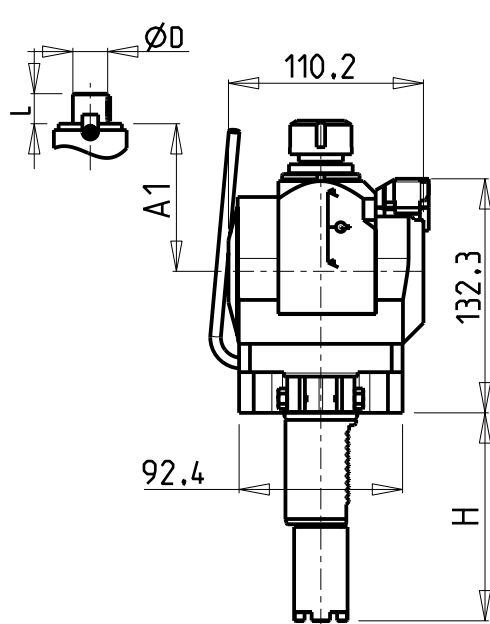

Cod. MT	Mandrino Spindle Spindel	I	RPM	Coppia Max Max Torque Max Drehmoment	Lubrificazione est. Ext. coolant Ausseukuehlung	A	A1	D	L	H	Tipo Torretta Turret Type Revolver Typ	CHIAVI INCLUSE Keys included Schluessel inbegriffen		
HAS0440120	ER20	1:1	6000	40Nm	X	85.16	-	-	-	104.85	VDI STANDARD	CHUB36	CHSTER20	NEW
HAS0450120	ER20	1:1	6000	40Nm	X	85.16	-	-	-	117.55	HYBRID 12 TURRET	CHUB36	CHSTER20	NEW
HAS0440125	ER25	1:1	6000	40Nm	X	86.16	-	-	-	104.85	VDI STANDARD	CHUB36	CHSTER25	NEW
HAS0450125	ER25	1:1	6000	40Nm	X	86.16	-	-	-	117.55	HYBRID 12 TURRET	CHUB36	CHSTER25	NEW
HAS0440516	Ø16x17	1:1	6000	40Nm	X	-	65	16	17	104.85	VDI STANDARD	CHUB36	CH_VTCROCE_M08	NEW
HAS0450516	Ø16x17	1:1	6000	40Nm	X	-	65	16	17	117.55	HYBRID 12 TURRET	CHUB36	CH_VTCROCE_M08	NEW
HAS0440522	Ø22x19	1:1	6000	40Nm	X	-	66	22	19	104.85	VDI STANDARD	CHUB36	CH_VTCROCE_M10	NEW
HAS0450522	Ø22x19	1:1	6000	40Nm	X	-	66	22	22	117.55	HYBRID 12 TURRET	CHUB36	CH_VTCROCE_M10	NEW
HAS0440519	Ø3/4"x3/4"	1:1	6000	40Nm	X	-	65	3/4"	3/4"	104.85	VDI STANDARD	CHUB36	CH_VTCROCE_M08	NEW
HAS0450519	Ø3/4"x3/4"	1:1	6000	40Nm	X	-	65	3/4"	3/4"	117.55	HYBRID 12 TURRET	CHUB36	CH_VTCROCE_M08	NEW

HAAS

MOD: SL10/20/30

MODULO MOTORIZZATO ORIENTABILE ±90° CON NONIO DIGITALE VD140  
 ±90° adjustable angle driven tool with digital display VD140  
 Angetriebenes Werkzeug schwenkbar ±90° mit digital display VD140

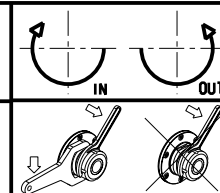

**M.T. srl**

Via Casino Albini 480  
 Tel. 0541/956034-957884  
 Fax 0541/956341

47842 S. GIOVANNI IN M. (RN)  
 e-mail: mtma@mtmarchetti.com  
 http://www.mtmarchetti.com

PRODUZIONE MODULI ROTANTI



PAGINA HAS333-1-01

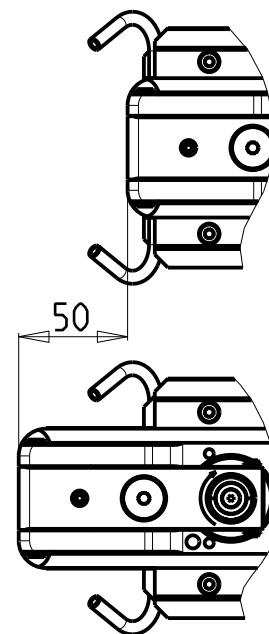
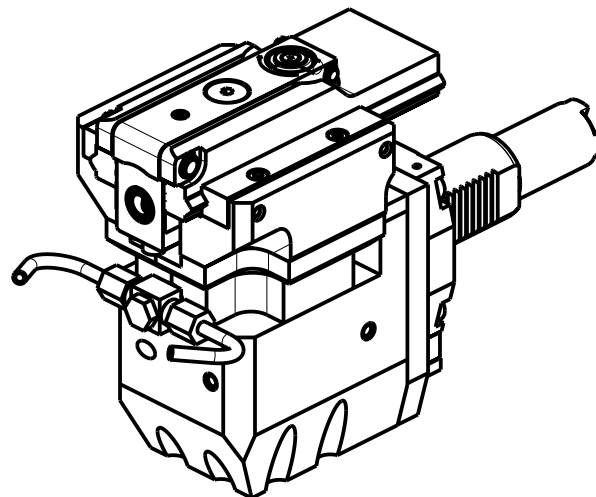
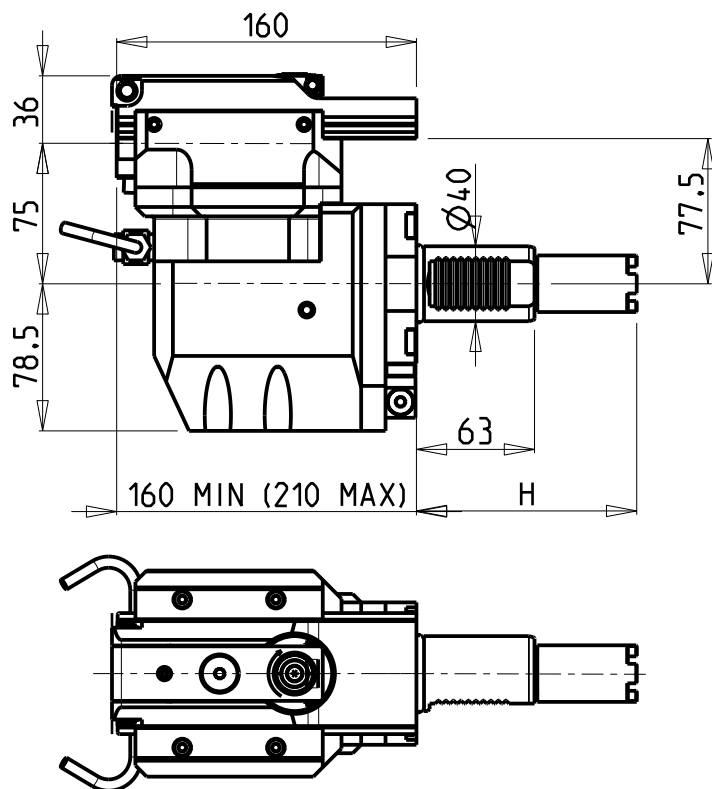
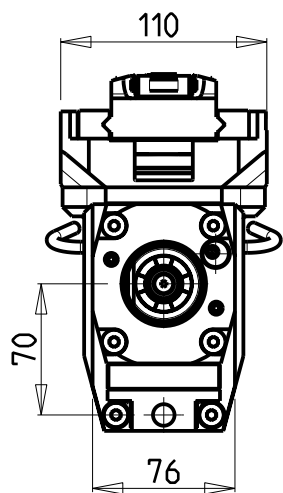

PER UTENSILI STOZZATORI VEDI PAG. TBL400-1-00  
 FOR DRIVEN SLOTTING TOOL CUTTING-TOOLS SEE PAGE TBL400-1-00  
 FÜR NUTENSTOSS-WERKZEUG SCHNEIDWERKZEUGE SIEHE SEITE TBL400-1-00

Cod. MT	I	RPM MAX	Lubr. esterna Ext. coolant Aussenkuehlung	H	Tipo Torretta Turret type Revolver typ	
HAS0360100	4:1	2000	X	104.85	VDI STANDARD	NEW
HAS0350100	4:1	2000	X	117.55	HYBRID 12 TURRET	NEW

HAAS

MOD: SL10/20/30

MODULO MOTORIZZATO STOZZATORE CORSA 50mm VDI40

Slotting driven tool 50mm stroke VDI40

Keilnutenstossmaschine 50mm Hub VDI40

**M.T. srl**

Via Casino Albini 480  
 Tel. 0541/956034-957884  
 Fax 0541/956341  
 47842 S. GIOVANNI IN M. (RN)  
 e-mail: mtma@mtmarchetti.com  
 http://www.mtmarchetti.com

PRODUZIONE MODULI ROTANTI



PAGINA HAS360-1-30

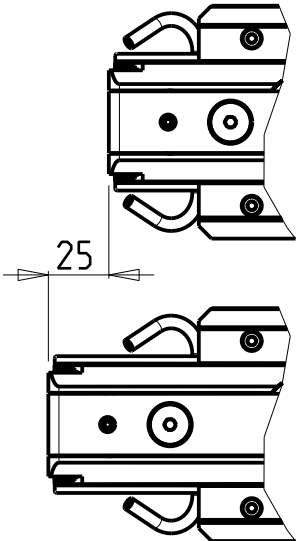
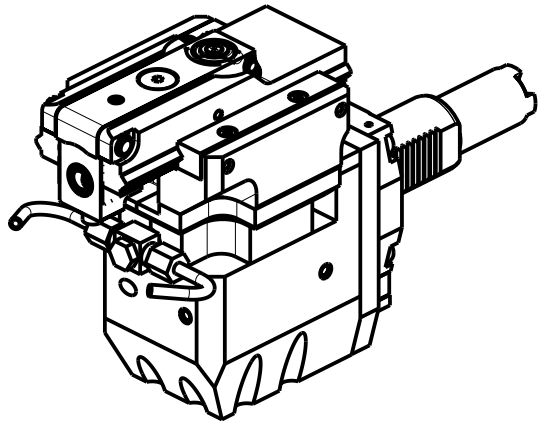
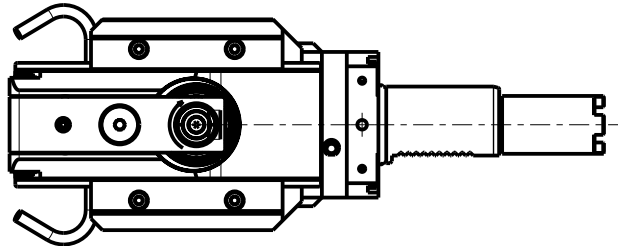
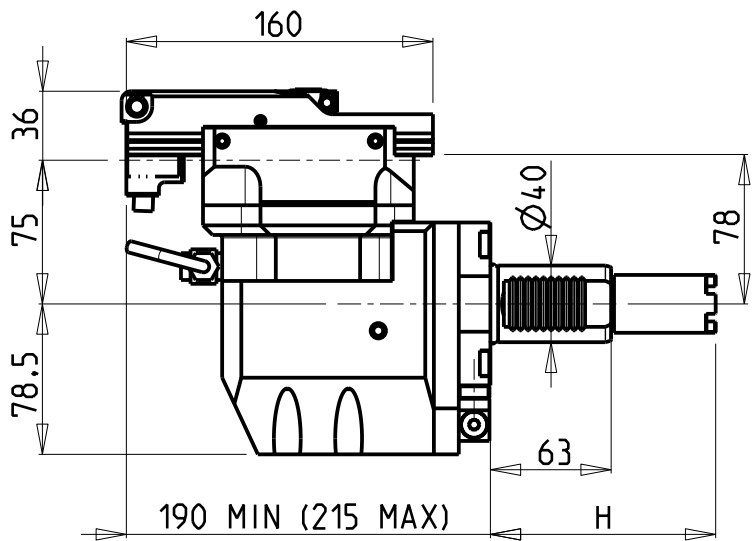
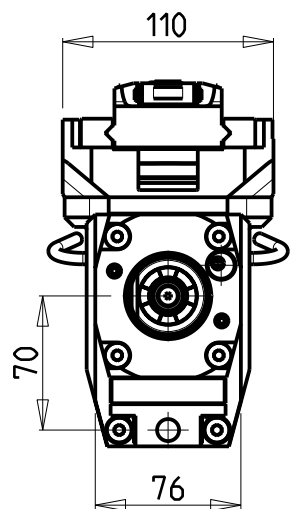

PER UTENSILI STOZZATORI VEDI PAG. TBL400-1-00  
 FOR DRIVEN SLOTTING TOOL CUTTING-TOOLS SEE PAGE TBL400-1-00  
 FÜR NUTENSTOSS-WERKZEUG SCHNEIDWERKZEUGE SIEHE SEITE TBL400-1-00

Cod. MT	I	RPM MAX	Lubr. esterna Ext. coolant Aussenkuehlung	H	Tipo Torretta Turret type Revolver typ	
HAS0360200	4:1	2400	X	104.85	VDI STANDARD	NEW
HAS0350200	4:1	2400	X	117.55	HYBRID 12 TURRET	NEW

HAAS  
 MOD: SL10/20/30  
 MODULO MOTORIZZATO STOZZATORE CORSA 25mm VDI40  
 Slotting driven tool 25mm stroke VDI40  
 Keilnutenstossmaschine 25mm Hub VDI40

**M.T. srl**  
 Via Casino Albini 480  
 Tel. 0541/956034-957884  
 Fax 0541/956341  
 47842 S. GIOVANNI IN M. (RN)  
 e-mail: mtma@mtmarchetti.com  
 http://www.mtmarchetti.com

PRODUZIONE MODULI ROTANTI



PAGINA HAS360-1-31

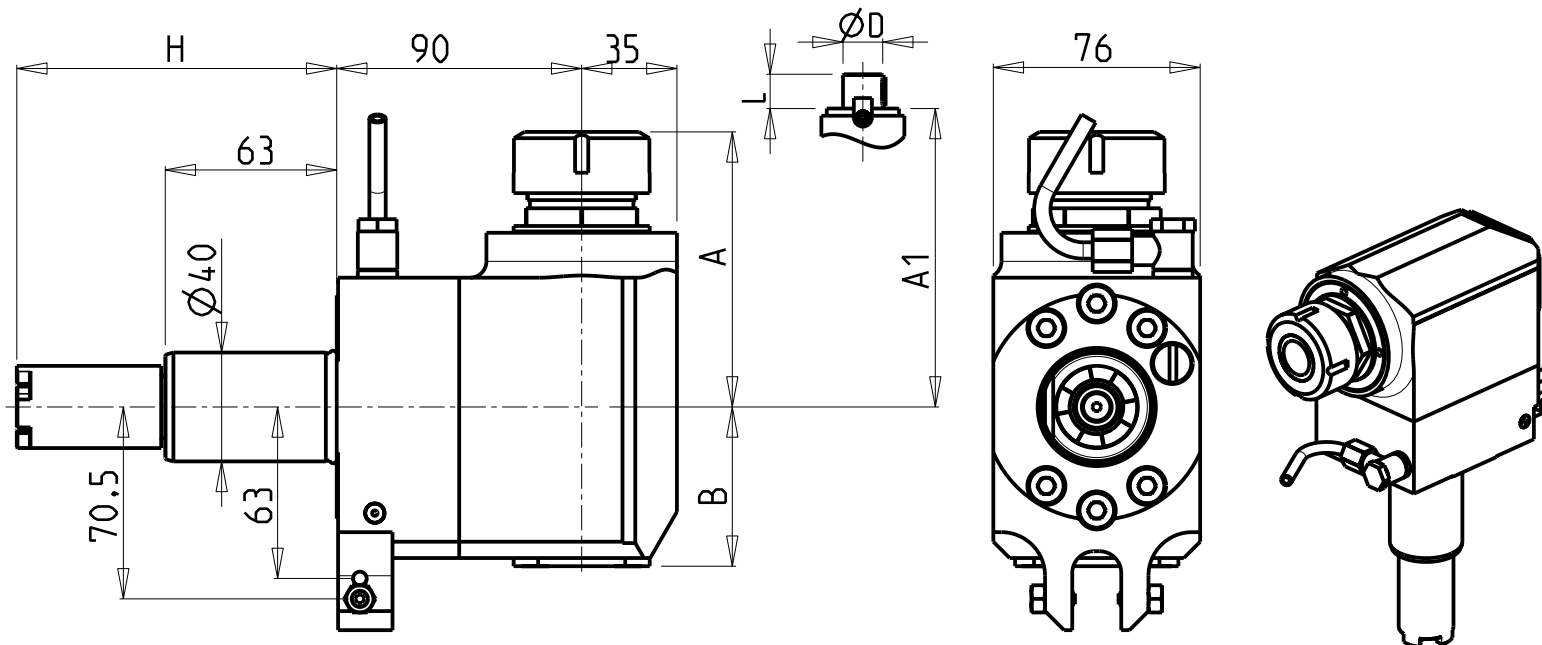

### ATTENZIONE - ATTENTION - ACHTUNG

- Per lo smontaggio degli utensili utilizzare sempre la chiave di contrasto come indicato nel manuale d'uso.
- For disassembly of the tools use always the contrast key as mentioned in the user instructions.
- Fuer das Abmontieren der Werkzeuge immer den Gegenschlüssel benutzen wie in der Bedienungsanleitung erwäehnt.

- Chiave inclusa
- Key included
- Schlüssel inbegriffen

Cod. MT	Mandrino Spindle Spindel	I	RPM	Coppia Max Max Torque Max Drehmoment	Lubrificazione int. Coolant through Innenkuhlung	Lubrificazione est. Ext. coolant Aussenkuhlung	A	A1	B	H	Tipo Torretta Turret type Revolver typ	CHIAVI NON INCLUSE Keys not included Schlüssel nicht einbegriffen	
HAS0140132	ER32	1:1	6000	70Nm		X	101.1	-	58.5	117.55	VDI STANDARD	CHUB41	CHSTER32
HAS0140232	ER32	1:1	6000	70Nm	P=70bar	X	101.1	-	82	117.55	VDI STANDARD	CHUB41	CHSTER32
HAS0142219	Ø22x19	1:1	6000	70Nm		X	-	78.5	58.5	117.55	VDI STANDARD	CHUB41	CH_VTCROCE_M10 •
HAS0142721	Ø27x21	1:1	6000	70Nm		X	-	78.5	58.5	117.55	VDI STANDARD	CHUB41	CH_VTCROCE_M12 •
HAS0180132	ER32	1:1	6000	70Nm		X	101.1	-	58.5	130.25	HYBRID 12 TURRET	CHUB41	CHSTER32
HAS0180232	ER32	1:1	6000	70Nm	P=70bar	X	101.1	-	82	130.25	HYBRID 12 TURRET	CHUB41	CHSTER32
HAS0182219	Ø22x19	1:1	6000	70Nm		X	-	78.5	58.5	130.25	HYBRID 12 TURRET	CHUB41	CH_VTCROCE_M10 •
HAS0182721	Ø27x21	1:1	6000	70Nm		X	-	78.5	58.5	130.25	HYBRID 12 TURRET	CHUB41	CH_VTCROCE_M12 •

HAAS

MOD: SL40 - ST40

MODULO MOTORIZZATO RADIALE VD140

Radial driven tool VD140

Radial angetriebenes Werkzeug VD140

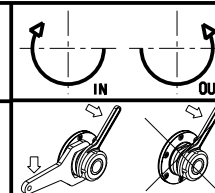

**M.T. srl**

Via Casino Albini 480  
Tel. 0541/956034-957884

Fax 0541/956341

47842 S. GIOVANNI IN M. (RN)

e-mail: mtma@mtmarchetti.com

http://www.mtmarchetti.com

PRODUZIONE MODULI ROTANTI



PAGINA HAS013-2-20

**ATTENZIONE - ATTENTION - ACHTUNG**

- Per lo smontaggio degli utensili utilizzare sempre la chiave di contrasto come indicato nel manuale d'uso.
- For disassembly of the tools use always the contrast key as mentioned in the user instructions.
- Fuer das Abmontieren der Werkzeuge immer den Gegenschlüssel benutzen wie in der Bedienungsanleitung erwahnt.

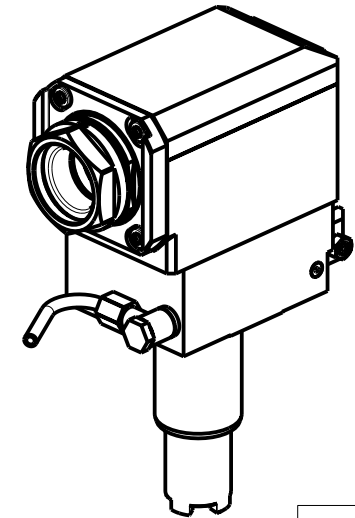
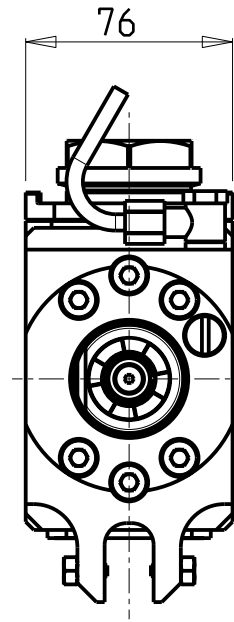
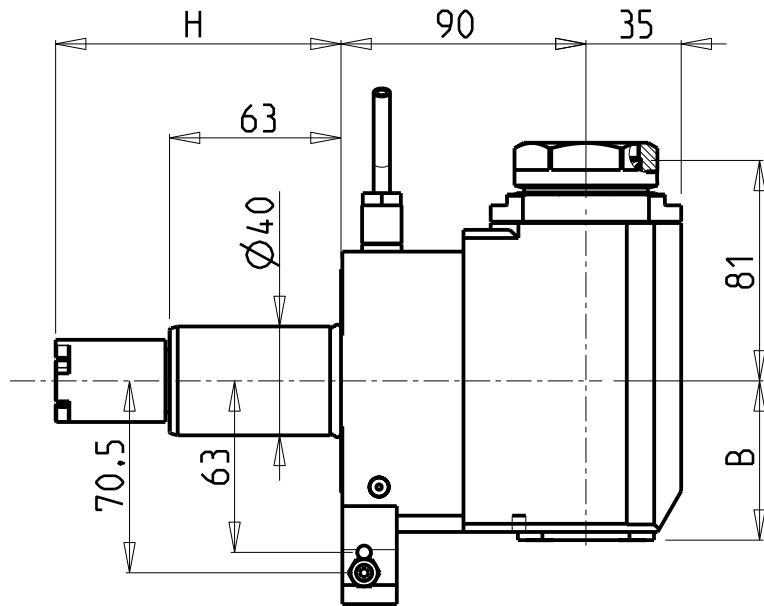

- Chiave inclusa
- Key included
- Schlüssell inbegriffen

PER PORTAUTENSILI MODULARI MTSK-40 VEDI PAG. TBL300-1-40  
 FOR MTSK-40 QUIK CHANGE TOOLHOLDERS CLAMPINGS SEE PAGE TBL300-1-40  
 FUER MTSK-40 MODULARE WERKZEUGAUFNAHMEN SIEHE SEITE TBL300-1-40

Cod. MT	Mandrino Spindle Spindel	I	RPM	Coppia Max Max Torque Max Drehmoment	Lubrificazione int. Coolant through Innenkuehlung	Lubrificazione est. Ext. coolant Aussenkuehlung	B	H	Tipo Torretta Turret type Revolver typ	CHIAVI NON INCLUSE Keys not included Schlüssell nicht einbegriffen	
HAS0280140	MTSK-40	1:1	6000	70Nm	-	X	58.5	117.55	VDI STANDARD	CHUB46	OKU0650004 •
HAS0280240	MTSK-40	1:1	6000	70Nm	P=70bar	X	69.5	117.55	VDI STANDARD	CHUB46	OKU0650004 •
HAS0260140	MTSK-40	1:1	6000	70Nm	-	X	58.5	130.25	HYBRID 12 TURRET	CHUB46	OKU0650004 •
HAS0260240	MTSK-40	1:1	6000	70Nm	P=70bar	X	69.5	130.25	HYBRID 12 TURRET	CHUB46	OKU0650004 •

HAAS  
 MOD: SL40 - ST40  
 MODULO MOTORIZZATO RADIALE MTSK VDI40  
 Radial MTSK driven tool VDI40  
 Radial MTSK angetriebenes Werkzeug VDI40

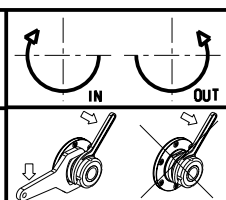

**M.T. srl**  
 Via Casino Albini 480  
 Tel. 0541/956034-957884  
 Fax 0541/956341  
 47842 S. GIOVANNI IN M. (RN)  
 e-mail: mtma@mtmarchetti.com  
 http://www.mtmarchetti.com

PRODUZIONE MODULI ROTANTI

PAGINA HAS013-2-20-K

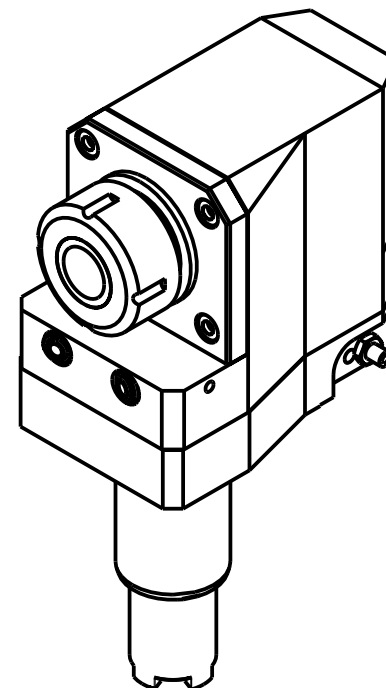
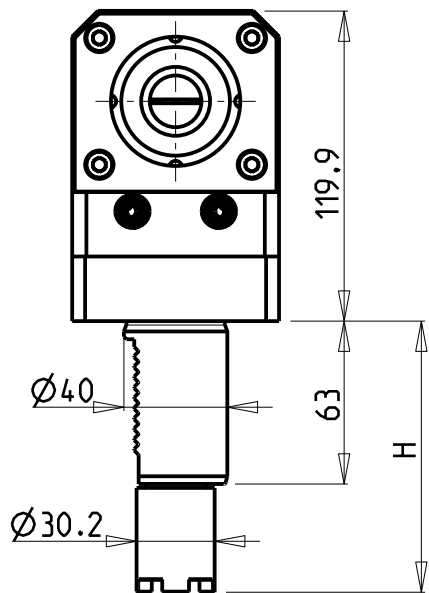
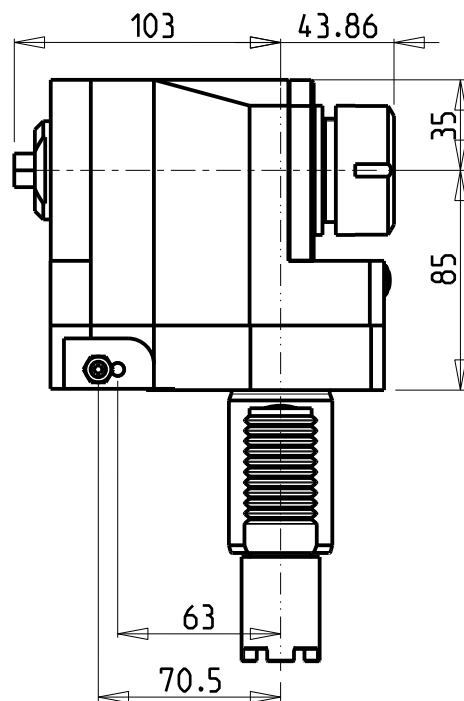
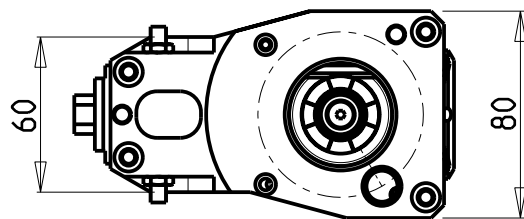

Cod. MT	Mandrino Spindle Spindel	I	RPM	Coppia Max Max Torque Max Drehmoment	Lubrificazione est. Ext. coolant Ausseukuehlung	H	Tipo Torretta Turret Type Revolver Typ	CHIAVI NON INCLUSE Keys not included Schluessel nicht einbegriffen	
HAS0040232	ER32	1:1	6000	70Nm	X	117.55	VDI STANDARD	CHUB13	CHSTER32
HAS0190232	ER32	1:1	6000	70Nm	X	130.25	HYBRID 12 TURRET	CHUB13	CHSTER32

HAAS  
MOD: SL40 - ST40

MODULO MOTORIZZATO RADIALE ARRETRATO VDI40  
Radial rear-set driven tool VDI40  
Radial angetriebenes Werkzeug zurueckversetzt VDI40

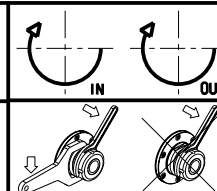

**M.T. srl**  
Via Casino Albini 480  
Tel. 0541/956034-957884  
Fax 0541/956341  
47842 S. GIOVANNI IN M. (RN)  
e-mail: mtma@mtmarchetti.com  
http://www.mtmarchetti.com

PRODUZIONE MODULI ROTANTI



PAGINA HAS015-2-00

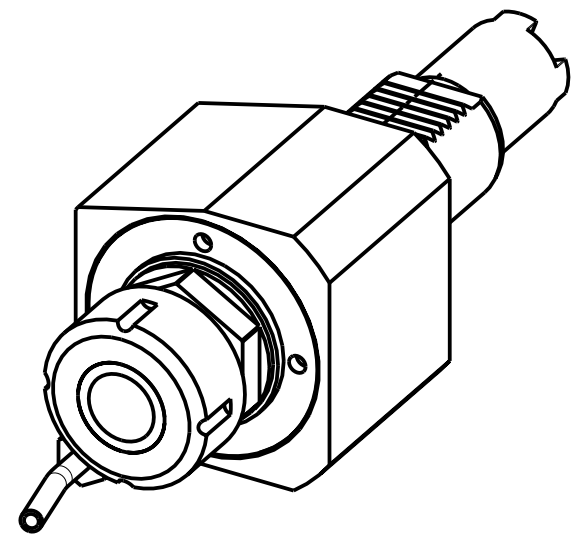
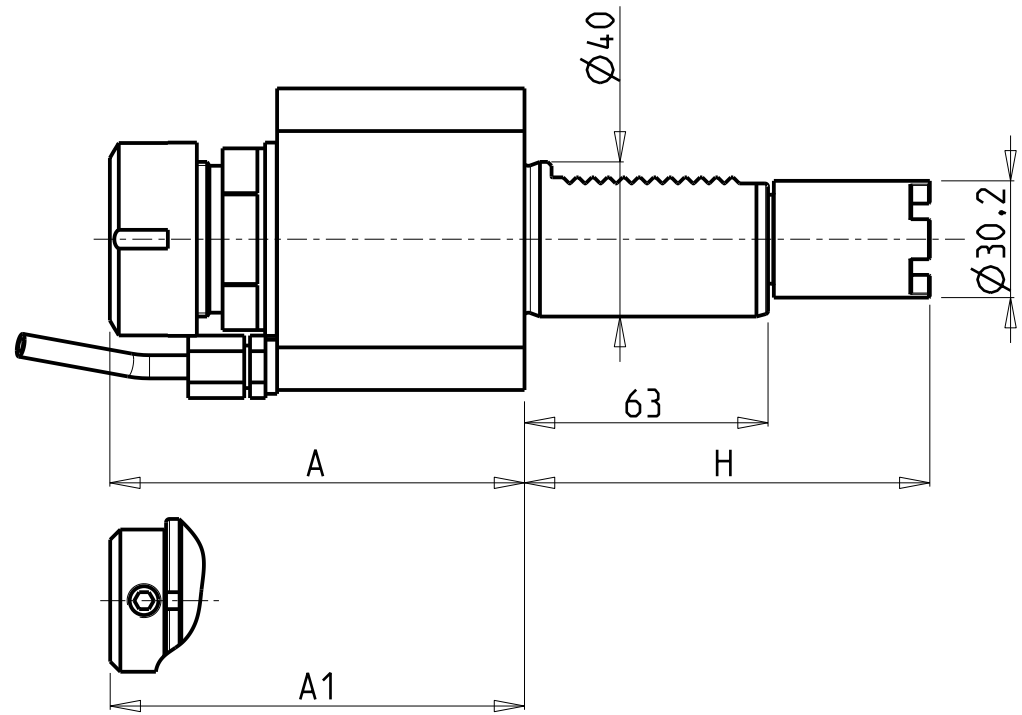
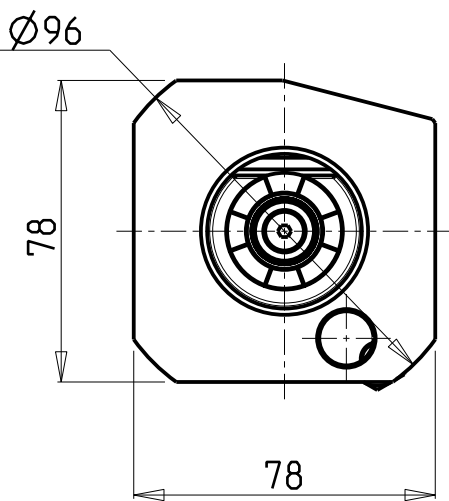

Cod. MT	Mandrino Spindle Spindel	I	RPM	Coppia Max Max Torque Max Drehmoment	Lubrificazione est. Ext. coolant Aussenkuehlung	Lubrificazione int. Coolant through Innenkuehlung	A	A1	H	Tipo Torretta Turret Type Revolver Typ	CHIAVI NON INCLUSE Keys not included Schlüssel nicht einbegriffen	
HAS0020232	ER32	1:1	6000	70Nm	X	-	107.26	-	117.55	VDI STANDARD	CHUB41	CHSTER32
HAS0020132	ER32	1:1	6000	70Nm	X	P=30bar	110.46	-	117.55	VDI STANDARD	CHUB41	CHSTER32
HAS0020525	WELDON25	1:1	6000	70Nm	X	-	-	97.1	117.55	VDI STANDARD	-	-
HAS0170232	ER32	1:1	6000	70Nm	X	-	107.26	-	130.25	HYBRID 12 TURRET	CHUB41	CHSTER32
HAS0170132	ER32	1:1	6000	70Nm	X	P=30bar	110.46	-	130.25	HYBRID 12 TURRET	CHUB41	CHSTER32
HAS0170525	WELDON25	1:1	6000	70Nm	X	-	-	97.1	130.25	HYBRID 12 TURRET	-	-

HAAS  
 MOD: SL40 - ST40  
 MODULO MOTORIZZATO ASSIALE VDI40  
 Axial driven tool VDI40  
 Axial angetriebenes Werkzeug VDI40

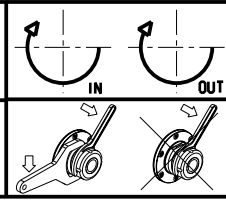

**M.T. srl**  
 Via Casino Albini 480  
 Tel. 0541/956034-957884  
 Fax 0541/956341  
 47842 S. GIOVANNI IN M. (RN)  
 e-mail: mtma@mtmarchetti.com  
 http://www.mtmarchetti.com

PRODUZIONE MODULI ROTANTI

PAGINA HAS150-2-10



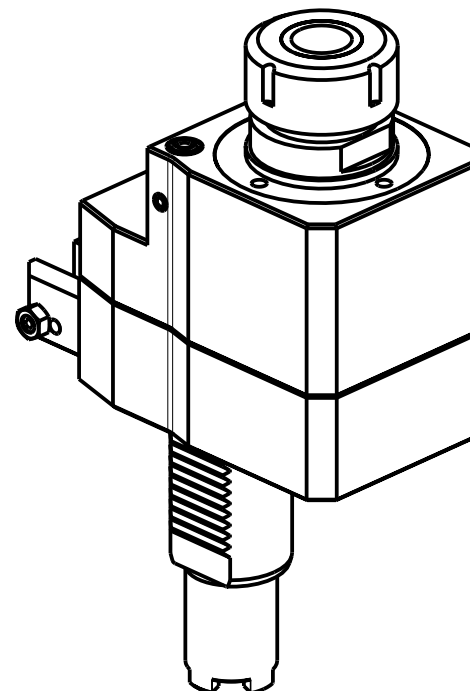
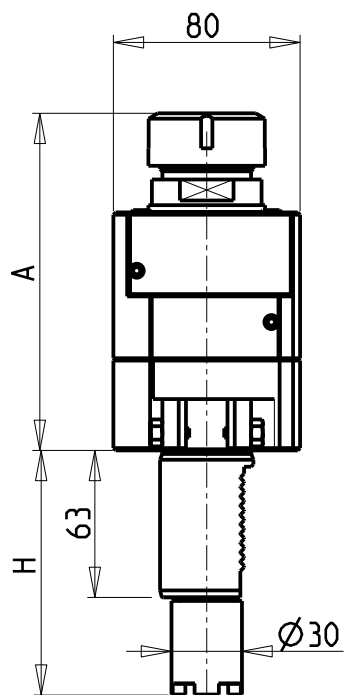
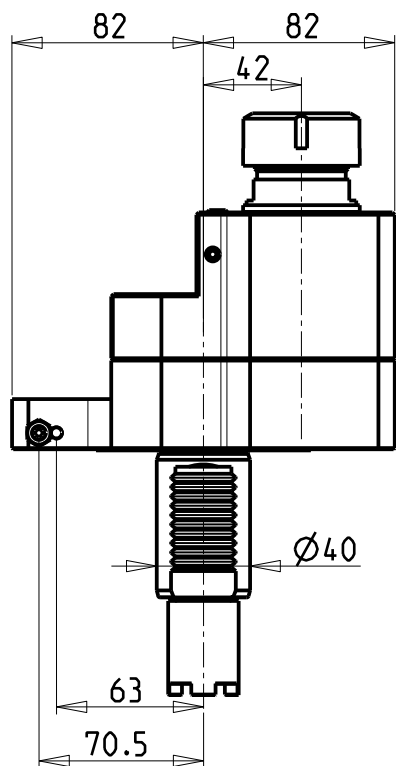

Cod. MT	Mandrino Spindle Spindel	I	RPM	Coppia Max Max Torque Max Drehmoment	Lubrificazione int. Coolant through Innenkühlung	Lubrificazione est. Ext. coolant Aussenkühlung	A	H	Tipo Torretta Turret Type Revolver Typ	CHIAVI NON INCLUSE Keys not included Schlüssel nicht einbegriffen	
HAS0080032	ER32	1:1	6000	70Nm		X	144.66	117.55	VDI STANDARD	CHUB41	CHSTER32
HAS0081132	ER32	1:1	6000	70Nm	P=30bar		164.96	117.55	VDI STANDARD	CHUB38	CHSTER32
HAS0082132	ER32	2:1	3000	100Nm		X	144.66	117.55	VDI STANDARD	CHUB41	CHSTER32
HAS0084232	ER32	2:1	3000	100Nm	P=30bar		164.96	117.55	VDI STANDARD	CHUB38	CHSTER32
HAS0200032	ER32	1:1	6000	70Nm		X	144.66	130.25	HYBRID 12 TURRET	CHUB41	CHSTER32
HAS0201132	ER32	1:1	6000	70Nm	P=30bar		164.96	130.25	HYBRID 12 TURRET	CHUB38	CHSTER32
HAS0202132	ER32	2:1	3000	100Nm		X	144.66	130.25	HYBRID 12 TURRET	CHUB41	CHSTER32
HAS0204232	ER32	2:1	3000	100Nm	P=30bar		164.96	130.25	HYBRID 12 TURRET	CHUB38	CHSTER32

HAAS

MOD: SL40 - ST40

MODULO MOTORIZZATO ASSIALE DISASSATO 42mm VDI40

Axial driven tool re-directed by 42mm VDI40

Axial angetriebenes Werkzeug achsversetzt um 42mm VDI40

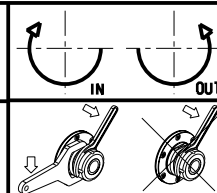

**M.T. srl**

Via Casino Albini 480  
Tel. 0541/956034-957884  
Fax 0541/956341

47842 S. GIOVANNI IN M. (RN)  
e-mail: mtma@mtmarchetti.com  
http://www.mtmarchetti.com

PRODUZIONE MODULI ROTANTI



PAGINA HAS160-2-00

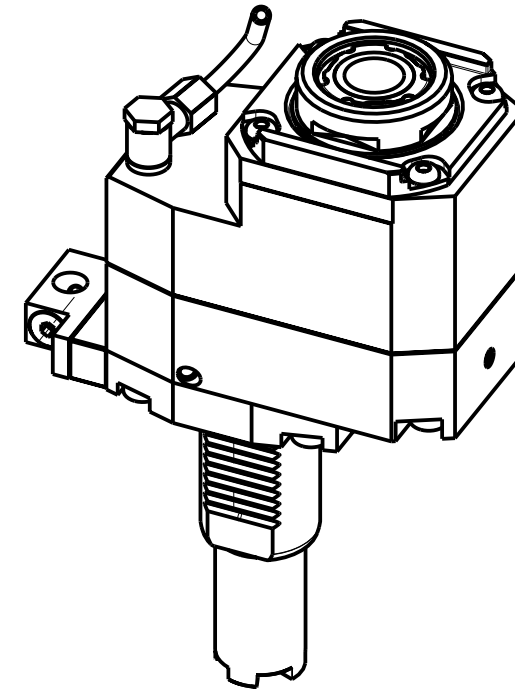
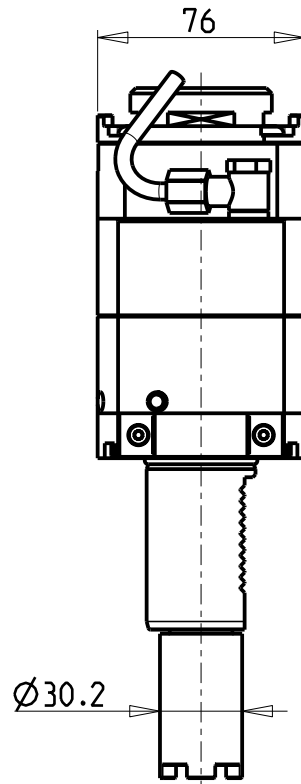
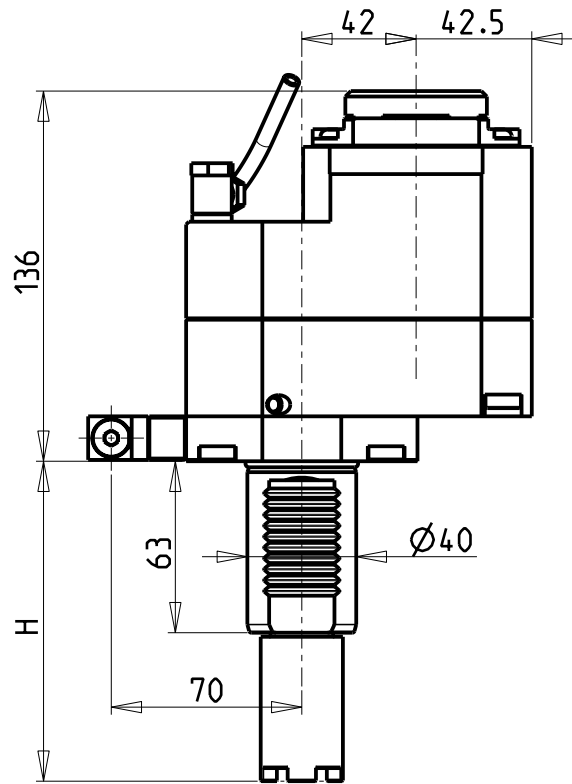

- Chiave inclusa
- Key included
- Schluessel inbegriffen

Cod. MT	Mandrino Spindle Spindel	I	RPM	Coppia Max Max Torque Max Drehmoment	Lubrificazione int. Coolant through Innenkühlung	Lubrificazione est. Ext. coolant Aussenkühlung	H	Tipo Torretta Turret Type Revolver Typ	CHIAVI NON INCLUSE Keys not included Schluessel nicht einbegriffen		
HAS0297132	ERA32	1:2	12000	45Nm	-	X	130.25	HYBRID 12 TURRET	C HUB30	CHTAER32ZC	OKU0650004
HAS0297232	ERA32	1:2	12000	45Nm	P=30bar	X	130.25	HYBRID 12 TURRET	C HUB30	CHTAER32ZC	OKU0650004
HAS0317132	ERA32	1:2	12000	45Nm	-	X	117.55	VDI STANDARD	C HUB30	CHTAER32ZC	OKU0650004
HAS0317232	ERA32	1:2	12000	45Nm	P=30bar	X	117.55	VDI STANDARD	C HUB30	CHTAER32ZC	OKU0650004

HAAS  
MOD: SL40 - ST40

MODULO MOTORIZZATO ASSIALE MOLTIPLICATO I=1:2 DISASSATO 42mm VDI40  
Axial geared-up I=1:2 driven tool re-directed by 42mm VDI40  
Axial angetriebenes Werkzeug uebersetzt I=1:2 achsversetzt um 42mm VDI40

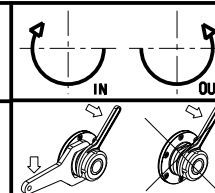

**M.T. srl**

Via Casino Albini 480  
Tel. 0541/956034-957884

Fax 0541/956341

47842 S. GIOVANNI IN M. (RN)  
e-mail: mtma@mtmarchetti.com  
http://www.mtmarchetti.com

PRODUZIONE MODULI ROTANTI



PAGINA HAS160-2-20

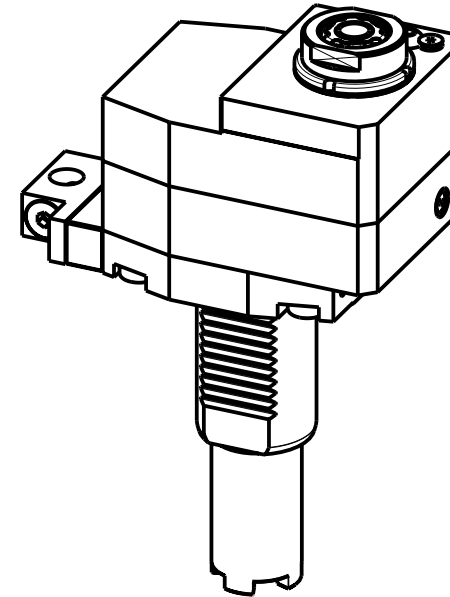
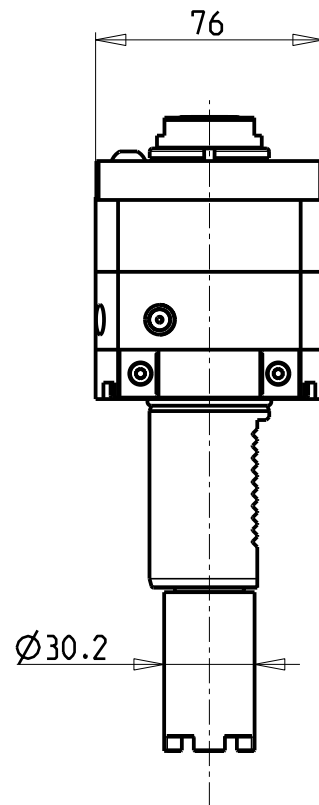
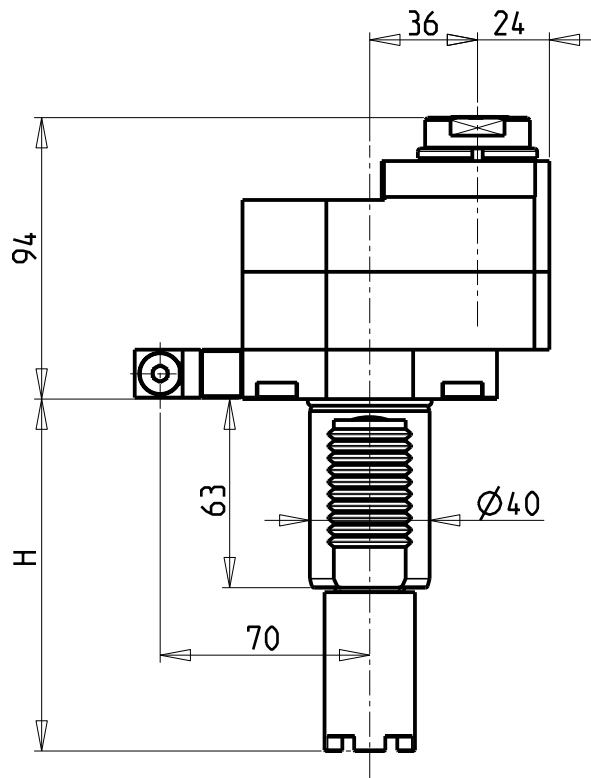

- Chiave inclusa
- Key included
- Schlüssel inbegriffen

Cod. MT	Mandrino Spindle Spindel	I	RPM	Coppia Max Max Torque Max Drehmoment	Lubrificazione int. Coolant through Innenkühlung	Lubrificazione est. Ext. coolant Aussenkühlung	H	Tipo Torretta Turret Type Revolver Typ	CHIAVI NON INCLUSE Keys not included Schlüssel nicht einbegriffen			
HAS0400116	ERA16	1:3	18000	10Nm	-	X	130.25	HYBRID 12 TURRET	C HUB30	C HUB19_SP3	C HTAER16ZC	• NEW
HAS0400216	ERA16	1:3	18000	10Nm	P=30bar	X	130.25	HYBRID 12 TURRET	C HUB30	C HUB19_SP3	C HTAER16ZC	• NEW
HAS0380116	ERA16	1:3	18000	10Nm	-	X	117.55	VDI STANDARD	C HUB30	C HUB19_SP3	C HTAER16ZC	• NEW
HAS0380216	ERA16	1:3	18000	10Nm	P=30bar	X	117.55	VDI STANDARD	C HUB30	C HUB19_SP3	C HTAER16ZC	• NEW

HAAS  
MOD: SL40 - ST40

MODULO MOTORIZZATO ASSIALE MOLTIPLICATO I=1:3 DISASSATO 36mm VDI40  
Axial geared-up I=1:3 driven tool re-directed by 36mm VDI40  
Axial angetriebenes Werkzeug uebersetzt I=1:3 achsversetzt um 36mm VDI40

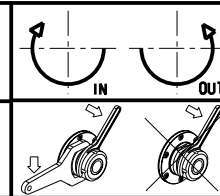

**M.T. srl**  
Via Casino Albini 480  
Tel. 0541/956034-957884  
Fax 0541/956341  
47842 S. GIOVANNI IN M. (RN)  
e-mail: mtma@mtmarchetti.com  
http://www.mtmarchetti.com

PRODUZIONE MODULI ROTANTI



PAGINA HAS160-2-30

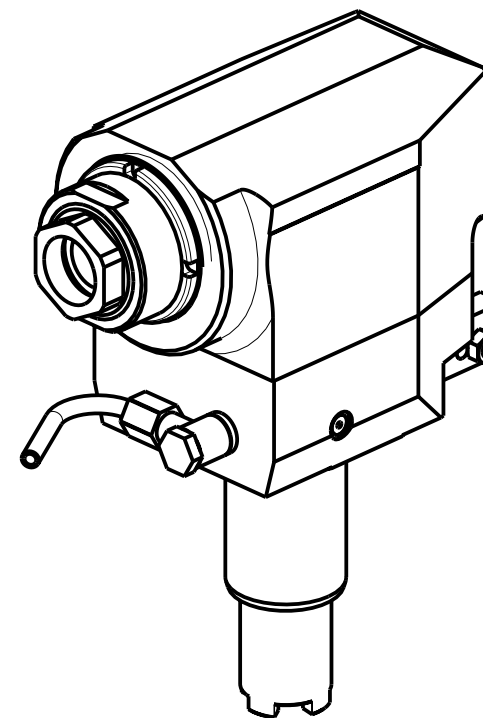
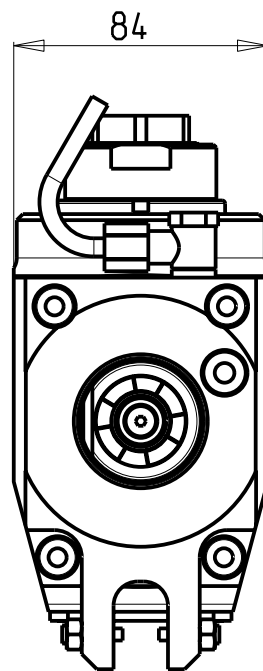
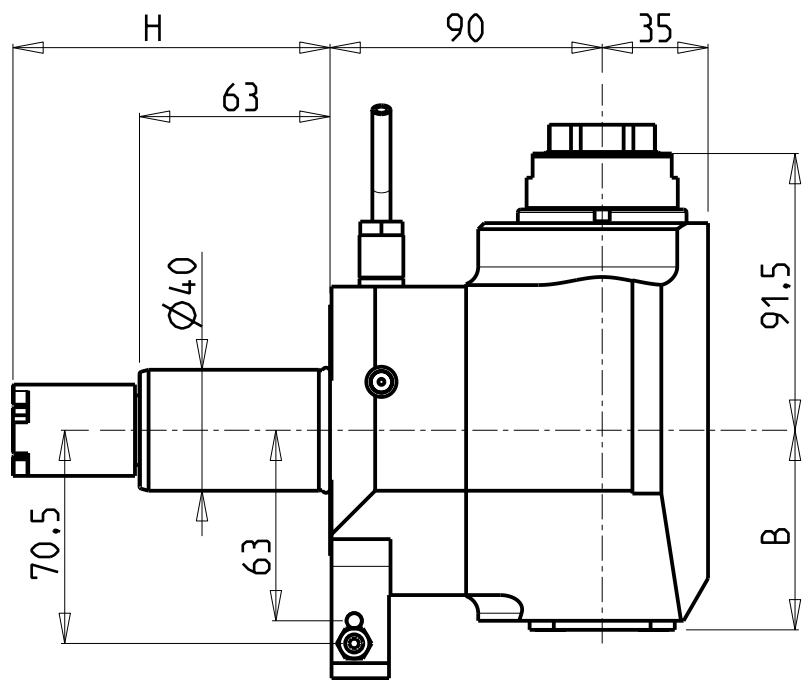

Cod. MT	Mandrino Spindle Spindel	I	RPM	Coppia Max Max Torque Max Drehmoment	Lubrificazione int. Coolant through Innenkühlung	Lubrificazione est. Ext. coolant Aussenkühlung	B	H	Tipo Torretta Turret type Revolver typ	CHIAVI NON INCLUSE Keys not included Schlüssel nicht einbegriffen	
HAS0160132	ERA32	1:2	12000	30Nm		X	66	117.55	VDI STANDARD	CHUB41	CHUB32
HAS0160232	ERA32	1:2	12000	30Nm	P=70bar	X	76	117.55	VDI STANDARD	CHUB41	CHUB32
HAS0210132	ERA32	1:2	12000	30Nm		X	66	130.25	HYBRID 12 TURRET	CHUB41	CHUB32
HAS0210232	ERA32	1:2	12000	30Nm	P=70bar	X	76	130.25	HYBRID 12 TURRET	CHUB41	CHUB32

HAAS  
MOD: SL40 - ST40

MODULO MOTORIZZATO RADIALE MOLTIPLICATO I=1:2 VDI40  
Radial geared-up I=1:2 driven tool VDI40  
Radial angetriebenes Werkzeug uebersezt I=1:2 VDI40

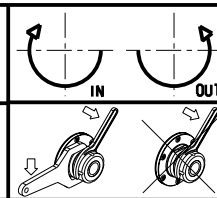

**M.T. srl**  
Via Casino Albini 480  
Tel. 0541/956034-957884  
Fax 0541/956341  
47842 S. GIOVANNI IN M. (RN)  
e-mail: mtma@mtmarchetti.com  
http://www.mtmarchetti.com

PRODUZIONE MODULI ROTANTI



PAGINA HAS203-2-10

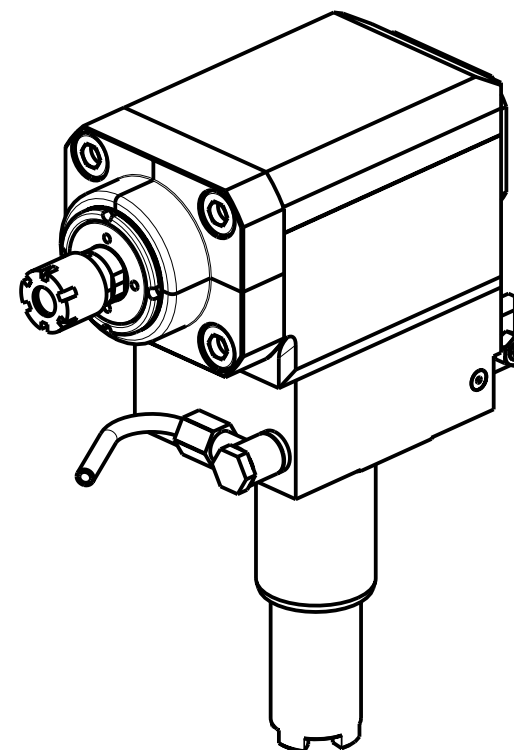
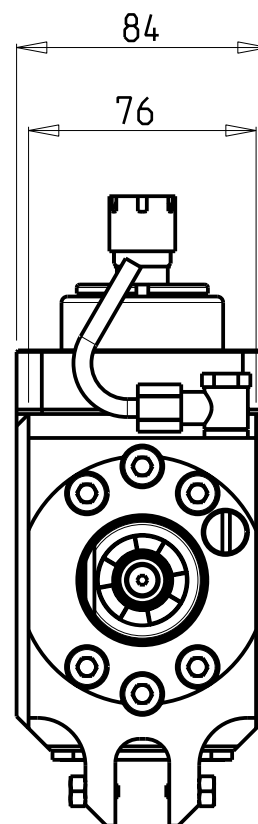
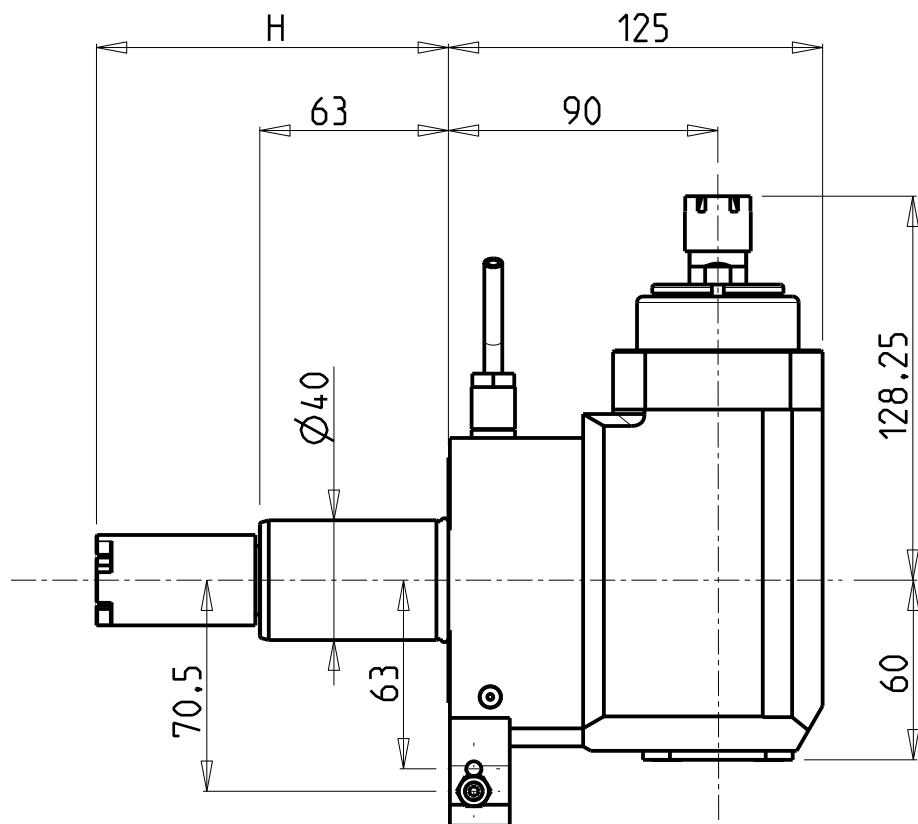

Cod. MT	Mandrino Spindle Spindel	I	RPM	Coppia Max Max Torque Max Drehmoment	Lubrificazione est. Ext. coolant Aussenkuehlung	H	Tipo Torretta Turret type Revolver typ	CHIAVI INCLUSE Keys included Schluessel einbegriffen	
HAS0340016	ER16	1:3	18000	10Nm	X	117.55	VDI STANDARD	CHUB17	CHMNER16
HAS0320016	ER16	1:3	18000	10Nm	X	130.25	HYBRID 12 TURRET	CHUB17	CHMNER16

HAAS  
MOD: SL40 - ST40

MODULO MOTORIZZATO RADIALE MOLTIPLICATO I=1:3 VDI40  
Radial geared-up I=1:3 driven tool VDI40  
Radial angetriebenes Werkzeug uebersezt I=1:3 VDI40

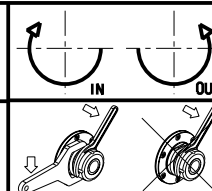

**M.T. srl**

Via Casino Albini 480  
Tel. 0541/956034-957884  
Fax 0541/956341

47842 S. GIOVANNI IN M. (RN)  
e-mail: mtma@mtmarchetti.com  
http://www.mtmarchetti.com

PRODUZIONE MODULI ROTANTI



PAGINA HAS208-2-10

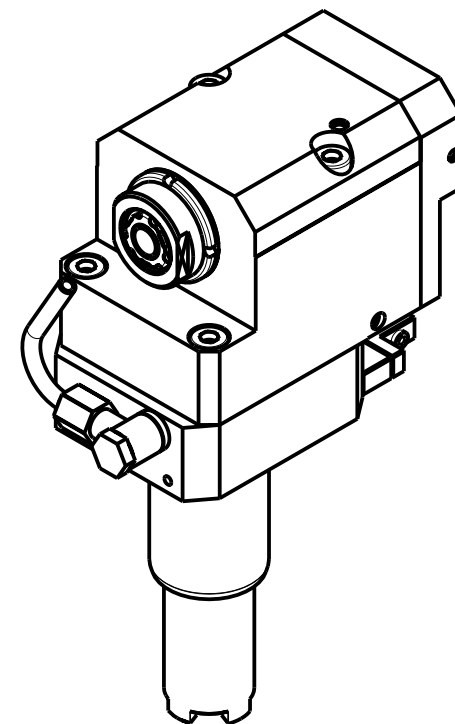
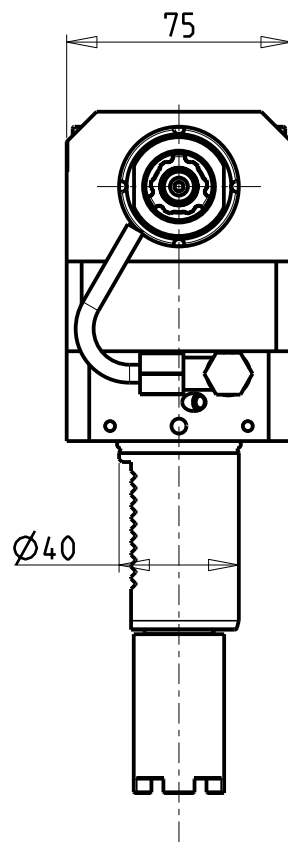
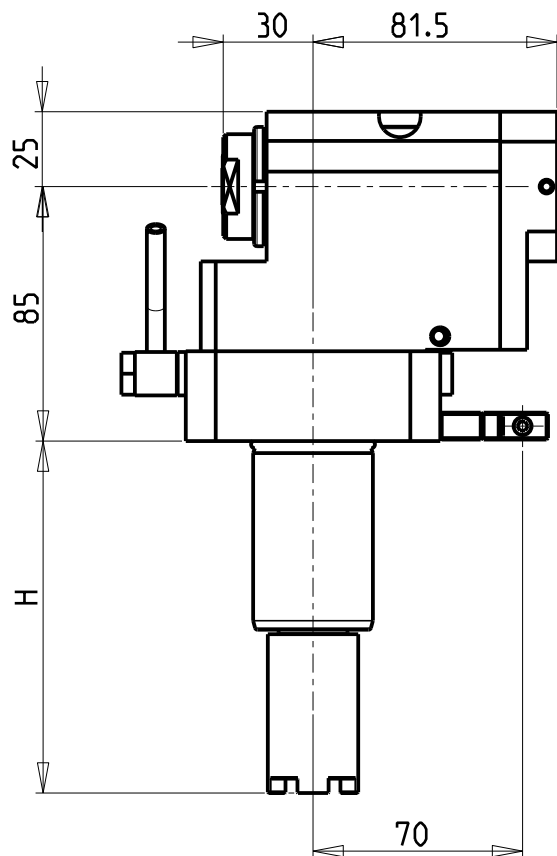

- Chiave inclusa
- Key included
- Schlüssel inbegriffen

Cod. MT	Mandrino Spindle Spindel	I	RPM	Coppia Max Max Torque Max Drehmoment	Lubrificazione int. Coolant through Innenkühlung	Lubrificazione est. Ext. coolant AusSENKühlung	H	Tipo Torretta Turret Type Revolver Typ	CHIAVI NON INCLUSE Keys not included Schlüssel nicht einbegriffen			
									C HUB30	C HUB19_SP3	C HTAER16ZC	
HAS0410116	ERA16	1:3	18000	10Nm	-	X	117.55	VDI STANDARD	C HUB30	C HUB19_SP3	C HTAER16ZC	• NEW
HAS0410216	ERA16	1:3	18000	10Nm	P=70bar	X	117.55	VDI STANDARD	C HUB30	C HUB19_SP3	C HTAER16ZC	• NEW
HAS0430116	ERA16	1:3	18000	10Nm	-	X	130.25	HYBRID 12 TURRET	C HUB30	C HUB19_SP3	C HTAER16ZC	• NEW
HAS0430216	ERA16	1:3	18000	10Nm	P=70bar	X	130.25	HYBRID 12 TURRET	C HUB30	C HUB19_SP3	C HTAER16ZC	• NEW

HAAS  
MOD: SL40 - ST40

MODULO MOTORIZZATO RADIALE ARRETRATO MOLTIPLICATO I=1:3 VDI40  
Radial geared-up I=1:3 rear-set driven tool VDI40  
Radial angetriebenes Werkzeug uebersezt I=1:3 zurueckversetzt VDI40

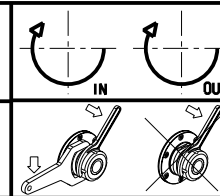

**M.T. srl**  
Via Casino Albini 480  
Tel. 0541/956034-957884  
Fax 0541/956341  
47842 S. GIOVANNI IN M. (RN)  
e-mail: mtma@mtmarchetti.com  
http://www.mtmarchetti.com

PRODUZIONE MODULI ROTANTI



PAGINA HAS226-2-10

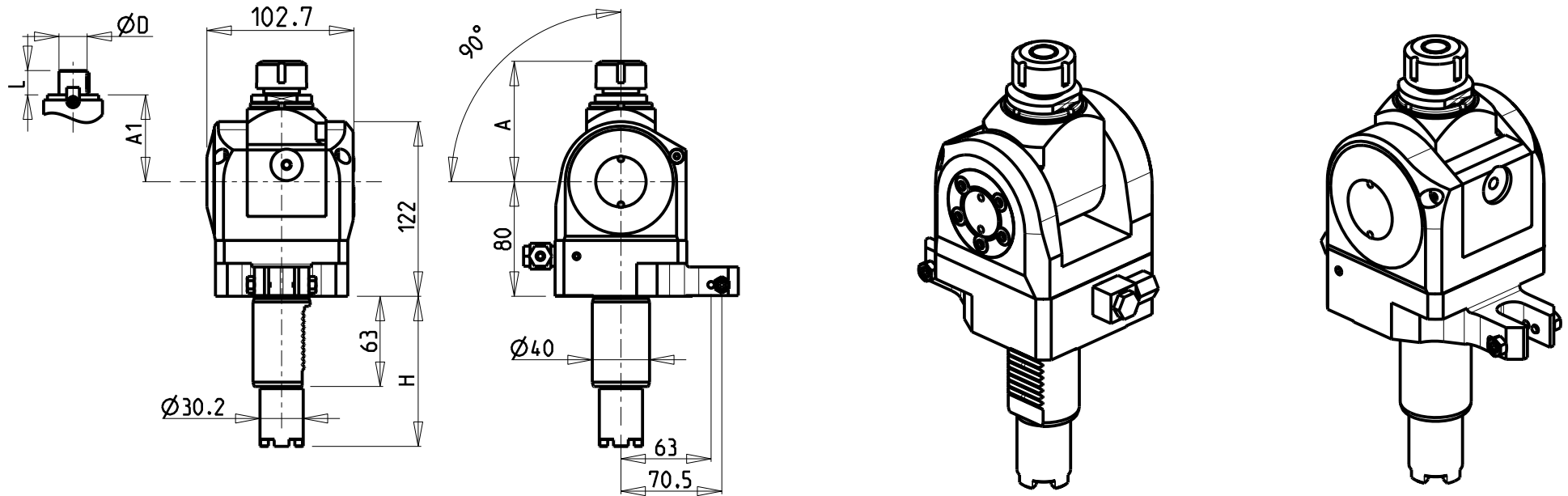

Cod. MT	Mandrino Spindle Spindel	I	RPM	Coppia Max Max Torque Max Drehmoment	Lubrificazione est. Ext. coolant Aussekkuehlung	A	A1	D	L	H	Tipo Torretta Turret Type Revolver Typ	CHIAVI INCLUSE Keys included Schluessel inbegriffen	
HAS0060020	ER20	1:1	6000	40Nm	X	84.16	-	-	-	117.55	VDI STANDARD	CHUB36	CHSTER20
HAS0220020	ER20	1:1	6000	40Nm	X	84.16	-	-	-	130.25	HYBRID 12 TURRET	CHUB36	CHSTER20
HAS0060025	ER25	1:1	6000	40Nm	X	85.66	-	-	-	117.55	VDI STANDARD	CHUB36	CHSTER25
HAS0220025	ER25	1:1	6000	40Nm	X	85.66	-	-	-	130.25	HYBRID 12 TURRET	CHUB36	CHSTER25
HAS0061617	Ø16x17	1:1	6000	40Nm	X	-	65	16	17	117.55	VDI STANDARD	CHUB36	CH_VTCROCE_M08
HAS0221617	Ø16x17	1:1	6000	40Nm	X	-	65	16	17	130.25	HYBRID 12 TURRET	CHUB36	CH_VTCROCE_M08
HAS0062219	Ø22x19	1:1	6000	40Nm	X	-	66	22	19	117.55	VDI STANDARD	CHUB36	CH_VTCROCE_M10
HAS0222219	Ø22x19	1:1	6000	40Nm	X	-	66	22	22	130.25	HYBRID 12 TURRET	CHUB36	CH_VTCROCE_M10
HAS0061905	Ø3/4"x3/4"	1:1	6000	40Nm	X	-	65	3/4"	3/4"	117.55	VDI STANDARD	CHUB36	CH_VTCROCE_M08
HAS0221905	Ø3/4"x3/4"	1:1	6000	40Nm	X	-	65	3/4"	3/4"	130.25	HYBRID 12 TURRET	CHUB36	CH_VTCROCE_M08

HAAS

MOD: SL40 - ST40

MODULO MOTORIZZATO ORIENTABILE 0-90° VDI40

0-90° adjustable angle driven tool VDI40

Angetriebenes Werkzeug schwenkbar 0-90° VDI40

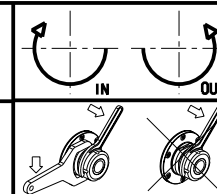

**M.T. srl**

Via Casino Albini 480  
Tel. 0541/956034-957884

Fax 0541/956341

47842 S. GIOVANNI IN M. (RN)

e-mail: mtma@mtmarchetti.com

http://www.mtmarchetti.com

PRODUZIONE MODULI ROTANTI



PAGINA HAS330-2-00

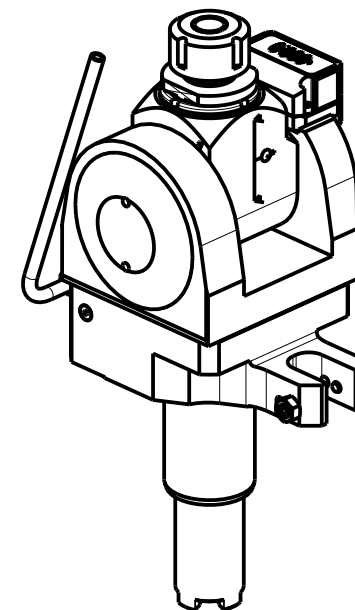
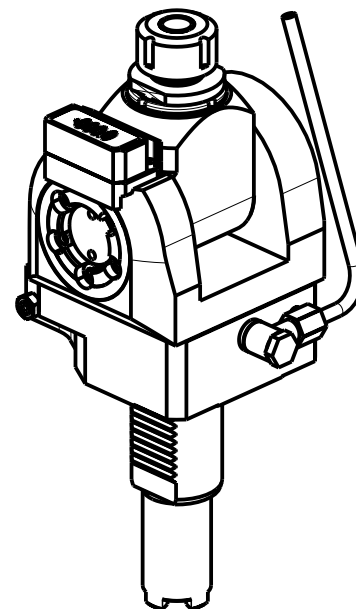
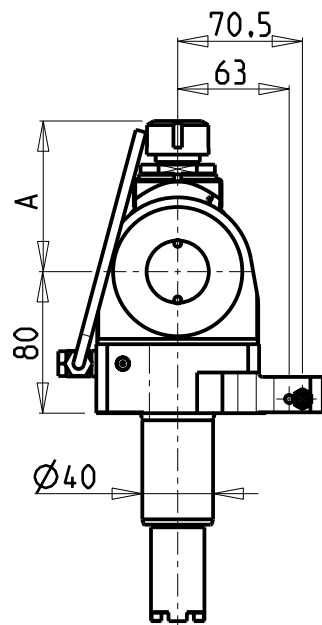
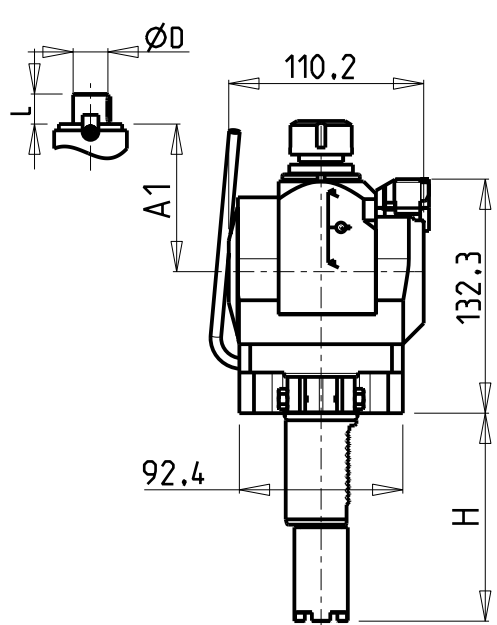

Cod. MT	Mandrino Spindle Spindel	I	RPM	Coppia Max Max Torque Max Drehmoment	Lubrificazione est. Ext. coolant Ausseukuehlung	A	A1	D	L	H	Tipo Torretta Turret Type Revolver Typ	CHIAVI INCLUSE Keys included Schluessel inbegriffen		
HAS0450120	ER20	1:1	6000	40Nm	X	85.16	-	-	-	117.55	VDI STANDARD	CHUB36	CHSTER20	NEW
HAS0460120	ER20	1:1	6000	40Nm	X	85.16	-	-	-	130.25	HYBRID 12 TURRET	CHUB36	CHSTER20	NEW
HAS0450125	ER25	1:1	6000	40Nm	X	86.16	-	-	-	117.55	VDI STANDARD	CHUB36	CHSTER25	NEW
HAS0460125	ER25	1:1	6000	40Nm	X	86.16	-	-	-	130.25	HYBRID 12 TURRET	CHUB36	CHSTER25	NEW
HAS0450516	Ø16x17	1:1	6000	40Nm	X	-	65	16	17	117.55	VDI STANDARD	CHUB36	CH_VTCROCE_M08	NEW
HAS0460516	Ø16x17	1:1	6000	40Nm	X	-	65	16	17	130.25	HYBRID 12 TURRET	CHUB36	CH_VTCROCE_M08	NEW
HAS0450522	Ø22x19	1:1	6000	40Nm	X	-	66	22	19	117.55	VDI STANDARD	CHUB36	CH_VTCROCE_M10	NEW
HAS0460522	Ø22x19	1:1	6000	40Nm	X	-	66	22	22	130.25	HYBRID 12 TURRET	CHUB36	CH_VTCROCE_M10	NEW
HAS0450519	Ø3/4"x3/4"	1:1	6000	40Nm	X	-	65	3/4"	3/4"	117.55	VDI STANDARD	CHUB36	CH_VTCROCE_M08	NEW
HAS0460519	Ø3/4"x3/4"	1:1	6000	40Nm	X	-	65	3/4"	3/4"	130.25	HYBRID 12 TURRET	CHUB36	CH_VTCROCE_M08	NEW

HAAS

MOD: SL40 - ST40

MODULO MOTORIZZATO ORIENTABILE ±90° CON NONIO DIGITALE VD140  
 ±90° adjustable angle driven tool with digital display VD140  
 Angetriebenes Werkzeug schwenkbar ±90° mit digital display VD140

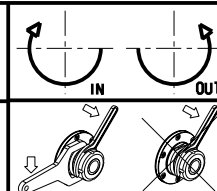

**M.T. srl**

Via Casino Albini 480  
 Tel. 0541/956034-957884  
 Fax 0541/956341

47842 S. GIOVANNI IN M. (RN)  
 e-mail: mtma@mtmarchetti.com  
 http://www.mtmarchetti.com

PRODUZIONE MODULI ROTANTI



PAGINA HAS333-2-01



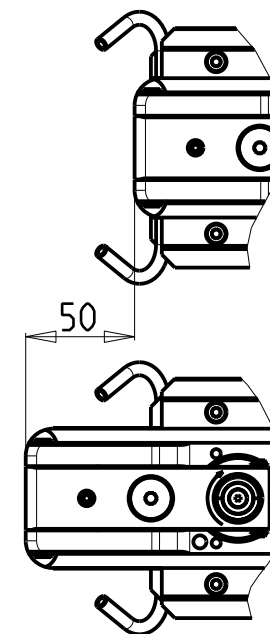
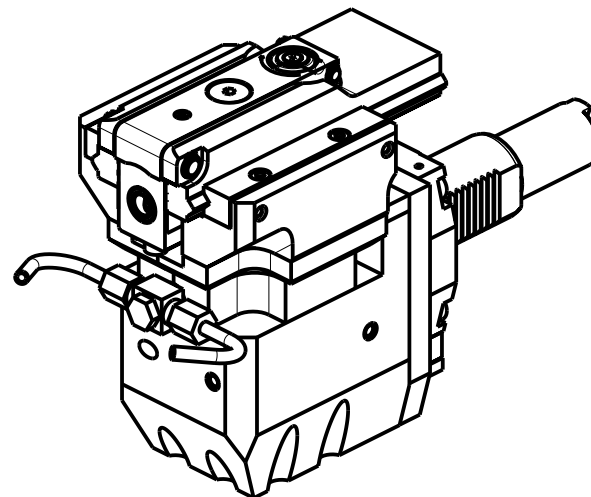
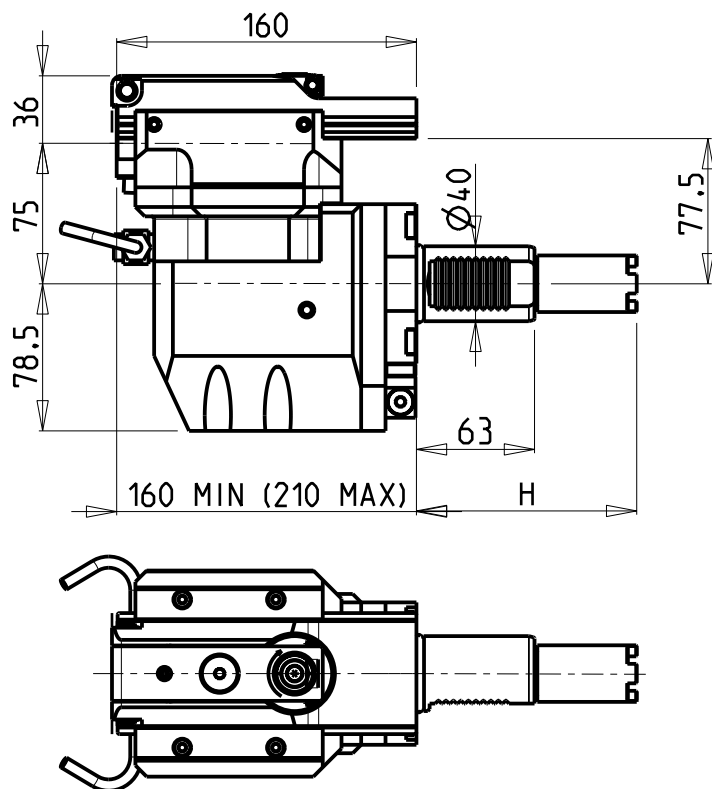
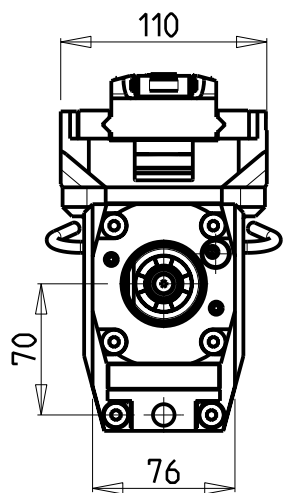

PER UTENSILI STOZZATORI VEDI PAG. TBL400-1-00  
 FOR DRIVEN SLOTTING TOOL CUTTING-TOOLS SEE PAGE TBL400-1-00  
 FÜR NUTENSTOSS-WERKZEUG SCHNEIDWERKZEUGE SIEHE SEITE TBL400-1-00

Cod. MT	I	RPM MAX	Lubr. esterna Ext. coolant Aussenkuehlung	H	Tipo Torretta Turret type Revolver typ	
HAS0350100	4:1	2000	X	117.55	VDI STANDARD	NEW
HAS0370100	4:1	2000	X	130.25	HYBRID 12 TURRET	NEW

HAAS

MOD: SL40 - ST40

MODULO MOTORIZZATO STOZZATORE CORSA 50mm VDI40

Slotting driven tool 50mm stroke VDI40

Keilnutenstossmaschine 50mm Hub VDI40

**M.T. srl**

Via Casino Albini 480  
 Tel. 0541/956034-957884  
 Fax 0541/956341  
 47842 S. GIOVANNI IN M. (RN)  
 e-mail: mtma@mtmarchetti.com  
 http://www.mtmarchetti.com

PRODUZIONE MODULI ROTANTI



PAGINA HAS360-2-30

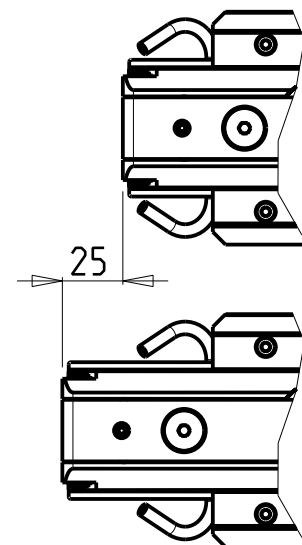
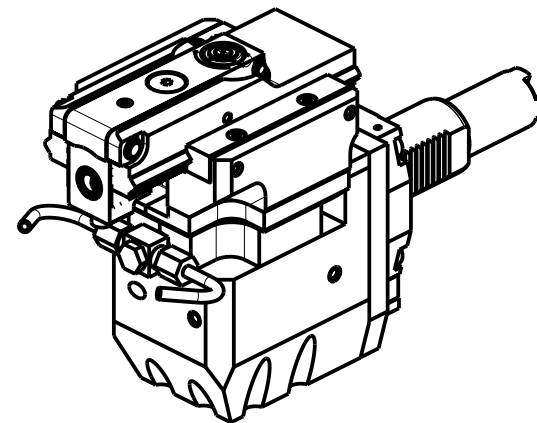
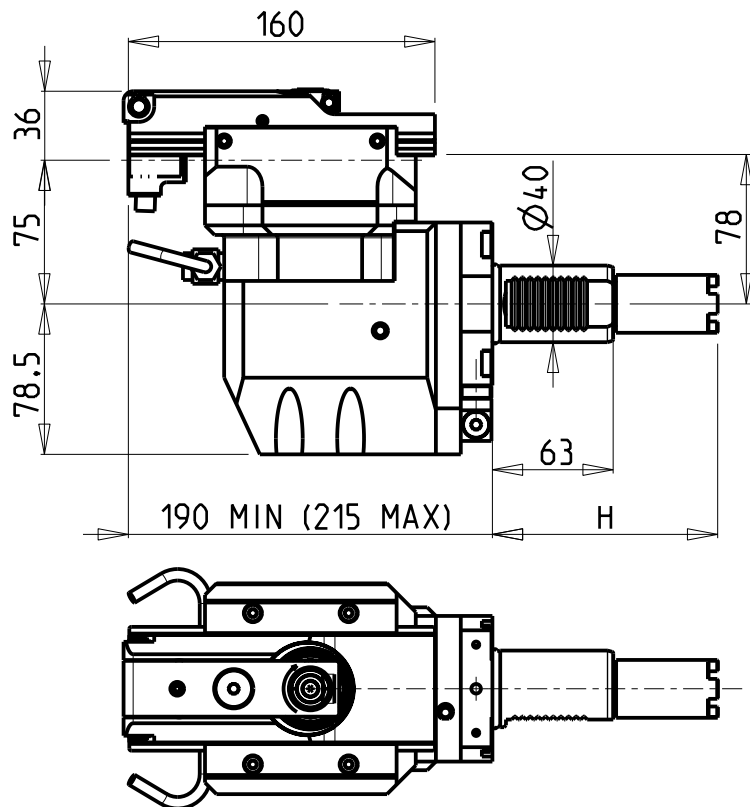
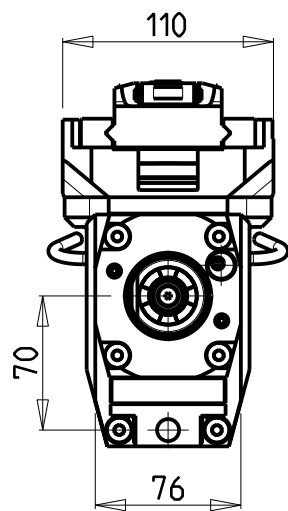

PER UTENSILI STOZZATORI VEDI PAG. TBL400-1-00  
 FOR DRIVEN SLOTTING TOOL CUTTING-TOOLS SEE PAGE TBL400-1-00  
 FÜR NUTENSTOSS-WERKZEUG SCHNEIDWERKZEUGE SIEHE SEITE TBL400-1-00

Cod. MT	I	RPM MAX	Lubr. esterna Ext. coolant Aussenkuehlung	H	Tipo Torretta Turret type Revolver typ	
HAS0350200	4:1	2400	X	117.55	VDI STANDARD	NEW
HAS0370200	4:1	2400	X	130.25	HYBRID 12 TURRET	NEW

HAAS

MOD: SL40 - ST40

MODULO MOTORIZZATO STOZZATORE CORSA 25mm VDI40

Slotting driven tool 25mm stroke VDI40

Keilnutenstossmaschine 25mm Hub VDI40

**M.T. srl**

Via Casino Albini 480  
 Tel. 0541/956034-957884  
 Fax 0541/956341  
 47842 S. GIOVANNI IN M. (RN)  
 e-mail: mtma@mtmarchetti.com  
 http://www.mtmarchetti.com

PRODUZIONE MODULI ROTANTI



PAGINA HAS360-2-31

**ATTENZIONE - ATTENTION - ACHTUNG**

- Per lo smontaggio degli utensili utilizzare sempre la chiave di contrasto come indicato nel manuale d'uso.
- For disassembly of the tools use always the contrast key as mentioned in the user instructions.
- Fuer das Abmontieren der Werkzeuge immer den Gegenschlüssel benutzen wie in der Bedienungsanleitung erwäehnt.

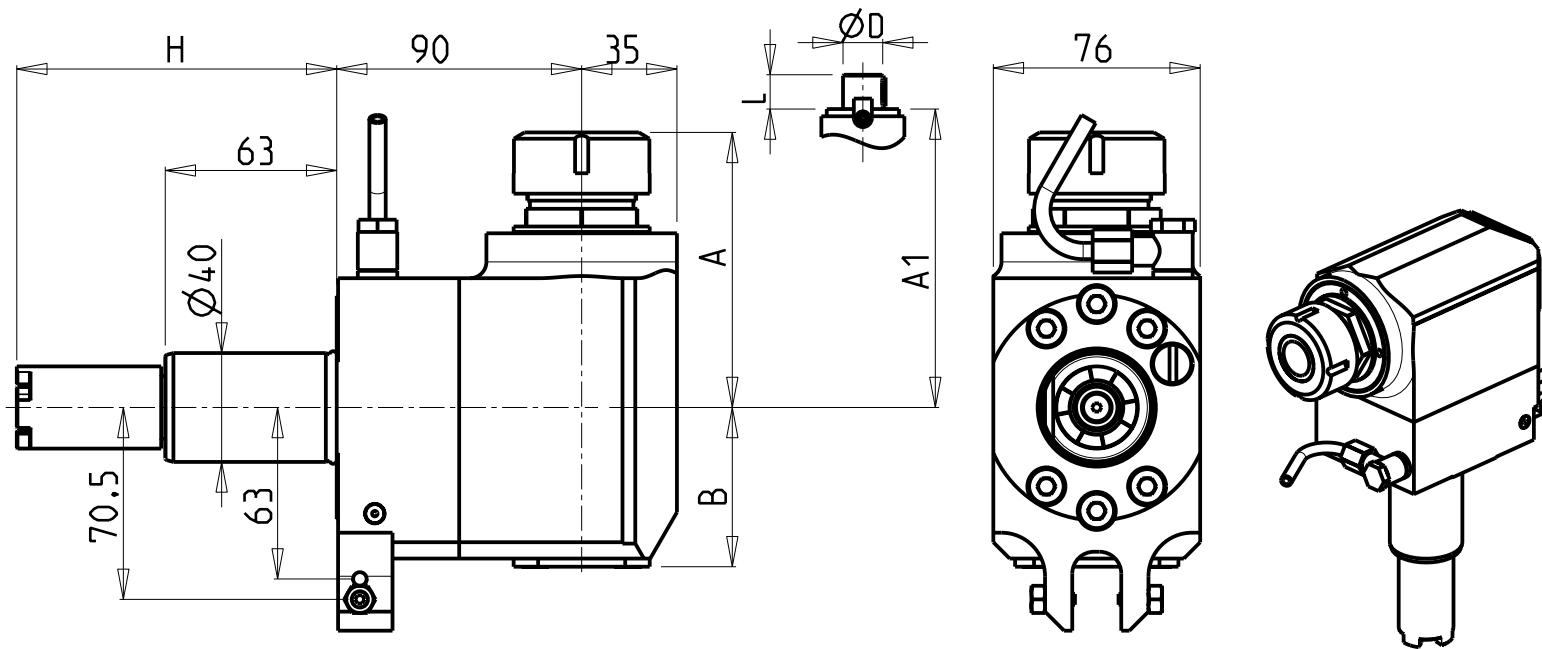

- Chiave inclusa
- Key included
- Schlüssel inbegriffen

Cod. MT	Mandrino Spindle Spindel	I	RPM	Coppia Max Max Torque Max Drehmoment	Lubrificazione int. Coolant through Innenkühlung	Lubrificazione est. Ext. coolant Ausenkühlung	A	A1	B	H	Tipo Torretta Turret type Revolver typ	CHIAVI NON INCLUSE Keys not included Schlüssel nicht einbegriffen	
HAS0140132	ER32	1:1	6000	70Nm		X	101.1	-	58.5	117.55	VDI STANDARD / HYBRID TURRET	CHUB41	CHSTER32
HAS0140232	ER32	1:1	6000	70Nm	P=70bar	X	101.1	-	82	117.55	VDI STANDARD / HYBRID TURRET	CHUB41	CHSTER32
HAS0142219	Ø22x19	1:1	6000	70Nm		X	-	78.5	58.5	117.55	VDI STANDARD / HYBRID TURRET	CHUB41	CH_VTCROCE_M10 •
HAS0142721	Ø27x21	1:1	6000	70Nm		X	-	78.5	58.5	117.55	VDI STANDARD / HYBRID TURRET	CHUB41	CH_VTCROCE_M12 •

HAAS

MOD: ST10/20/30 - DS30 - TL15/25

MODULO MOTORIZZATO RADIALE VD140

Radial driven tool VD140

Radial angetriebenes Werkzeug VD140

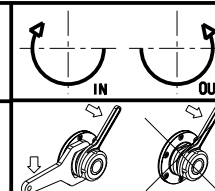

**M.T. srl**

Via Casino Albini 480  
Tel. 0541/956034-957884

Fax 0541/956341

47842 S. GIOVANNI IN M. (RN)

e-mail: mtma@mtmarchetti.com

http://www.mtmarchetti.com

PRODUZIONE MODULI ROTANTI



PAGINA HAS013-3-20

**ATTENZIONE - ATTENTION - ACHTUNG**

- Per lo smontaggio degli utensili utilizzare sempre la chiave di contrasto come indicato nel manuale d'uso.
- For disassembly of the tools use always the contrast key as mentioned in the user instructions.
- Fuer das Abmontieren der Werkzeuge immer den Gegenschlüssel benutzen wie in der Bedienungsanleitung erwäehnt.

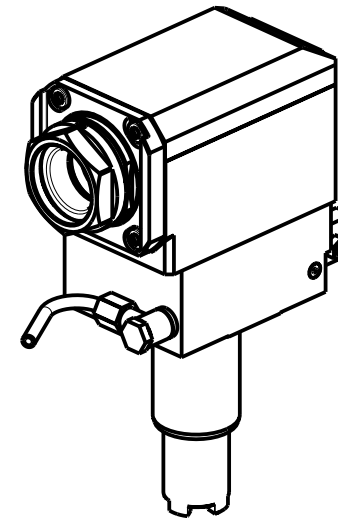
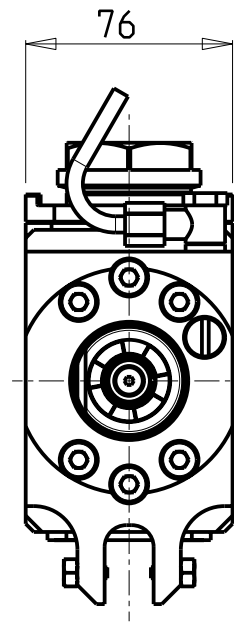
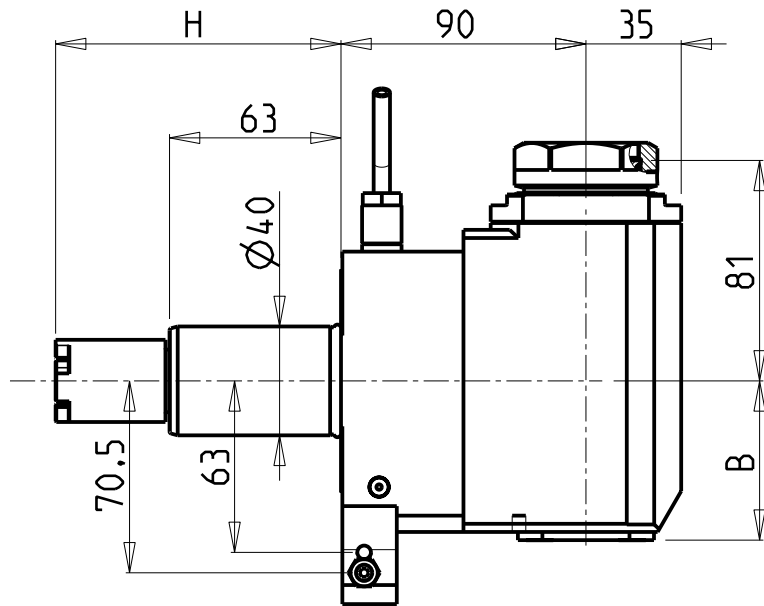

- Chiave inclusa
- Key included
- Schlüssel inbegriffen

PER PORTAUTENSILI MODULARI MTSK-40 VEDI PAG. TBL300-1-40  
 FOR MTSK-40 QUIK CHANGE TOOLHOLDERS CLAMPINGS SEE PAGE TBL300-1-40  
 FUER MTSK-40 MODULARE WERKZEUGAUFNAHMEN SIEHE SEITE TBL300-1-40

Cod. MT	Mandrino Spindle Spindel	I	RPM	Coppia Max Max Torque Max Drehmoment	Lubrificazione int. Coolant through Innenkuehlung	Lubrificazione est. Ext. coolant Aussenkuehlung	B	H	Tipo Torretta Turret type Revolver typ	CHIAVI NON INCLUDE Keys not included Schluessel nicht einbegriffen	
HAS0280140	MTSK-40	1:1	6000	70Nm	-	X	58.5	117.55	VDI STANDARD / HYBRID TURRET	CHUB46	OKU0650004 ▪
HAS0280240	MTSK-40	1:1	6000	70Nm	P=70bar	X	69.5	117.55	VDI STANDARD / HYBRID TURRET	CHUB46	OKU0650004 ▪

HAAS

MOD: ST10/20/30 - DS30 - TL15/25

MODULO MOTORIZZATO RADIALE MTSK VDI40

Radial MTSK driven tool VDI40

Radial MTSK angetriebenes Werkzeug VDI40

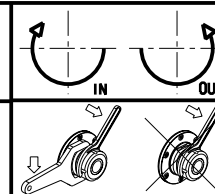

**M.T. srl**

Via Casino Albini 480  
 Tel. 0541/956034-957884

Fax 0541/956341

47842 S. GIOVANNI IN M. (RN)

e-mail: mtma@mtmarchetti.com

http://www.mtmarchetti.com

PRODUZIONE MODULI ROTANTI



PAGINA HAS013-3-20-K

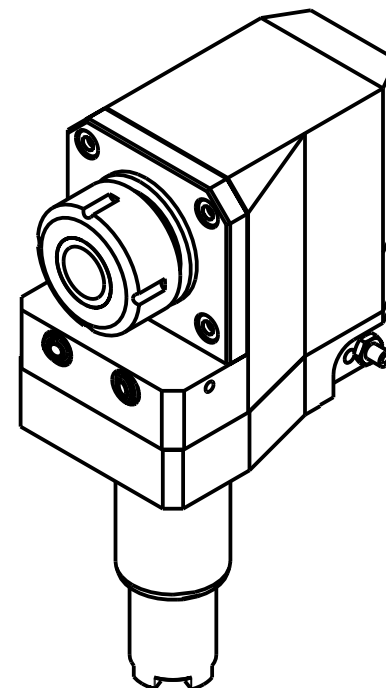
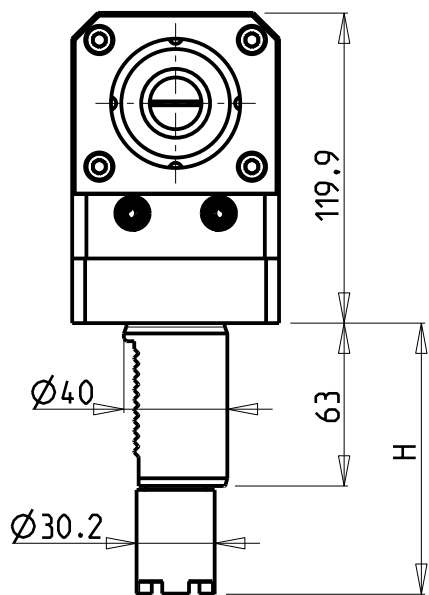
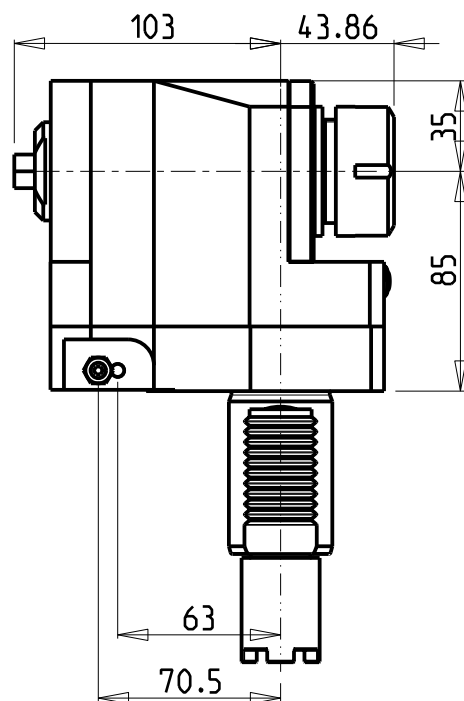
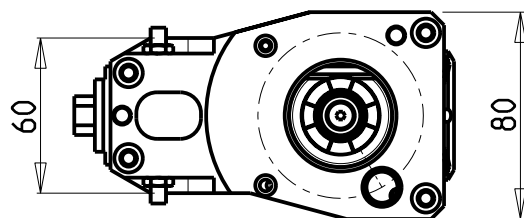

Cod. MT	Mandrino Spindle Spindel	I	RPM	Coppia Max Max Torque Max Drehmoment	Lubrificazione est. Ext. coolant Aussenkuehlung	H	Tipo Torretta Turret Type Revolver Typ	CHIAVI NON INCLUSE Keys not included Schluesssel nicht einbegriffen	
HAS0040232	ER32	1:1	6000	70Nm	X	117.55	VDI STANDARD / HYBRID TURRET	CHUB13	CHSTER32

HAAS

MOD: ST10/20/30 - DS30 - TL15/25

MODULO MOTORIZZATO RADIALE ARRETRATO VDI40

Radial rear-set driven tool VDI40

Radial angetriebenes Werkzeug zurueckversetzt VDI40

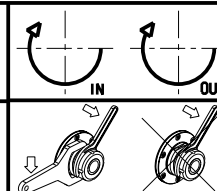

**M.T. srl**

Via Casino Albini 480  
Tel. 0541/956034-957884

Fax 0541/956341

47842 S. GIOVANNI IN M. (RN)

e-mail: mtma@mtmarchetti.com

http://www.mtmarchetti.com

PRODUZIONE MODULI ROTANTI



PAGINA HAS015-3-00

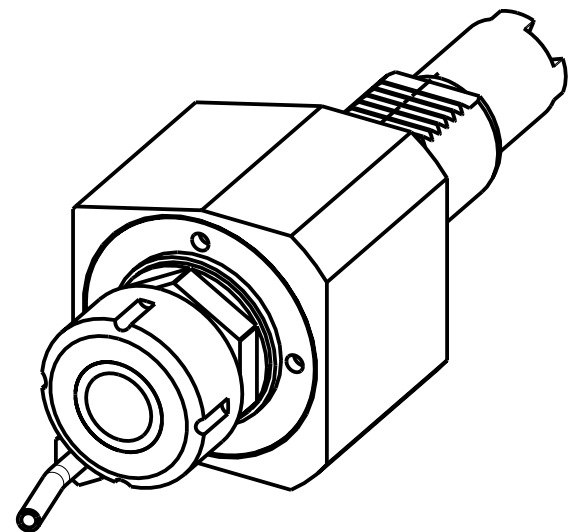
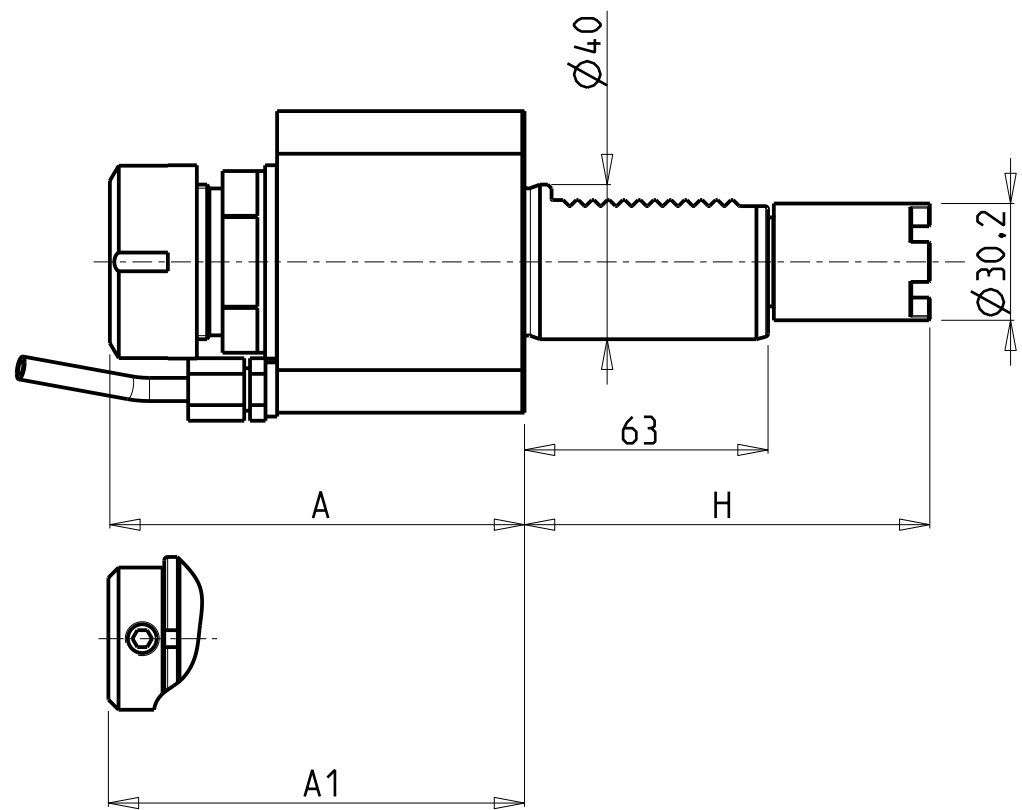
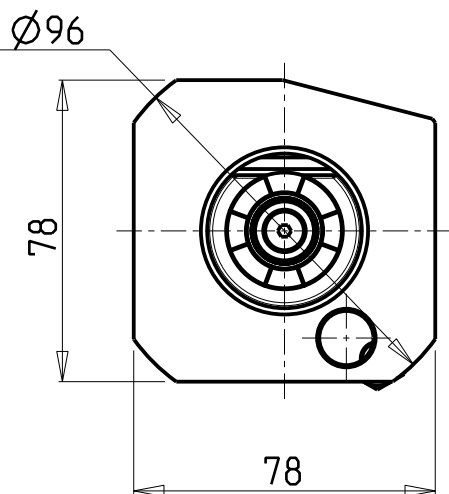

Cod. MT	Mandrino Spindle Spindel	I	RPM	Coppia Max Max Torque Max Drehmoment	Lubrificazione est. Ext. coolant Aussenkuehlung	Lubrificazione int. Coolant through Innenkuehlung	A	A1	H	Tipo Torretta Turret Type Revolver Typ	CHIAVI NON INCLUSE Keys not included Schlüssel nicht einbegriffen	
HAS0020232	ER32	1:1	6000	70Nm	X	-	107.26	-	117.55	VDI STANDARD / HYBRID TURRET	CHUB41	CHSTER32
HAS0020132	ER32	1:1	6000	70Nm	X	P=30bar	110.46	-	117.55	VDI STANDARD / HYBRID TURRET	CHUB41	CHSTER32
HAS0020525	WELDON25	1:1	6000	70Nm	X	-	-	97.1	117.55	VDI STANDARD / HYBRID TURRET	-	-

HAAS  
 MOD: ST10/20/30 - DS30 - TL15/25  
 MODULO MOTORIZZATO ASSIALE VDI40  
 Axial driven tool VDI40  
 Axial angetriebenes Werkzeug VDI40

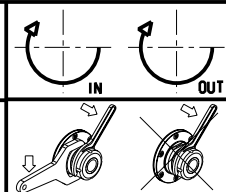

**M.T. srl**  
 Via Casino Albini 480  
 Tel. 0541/956034-957884  
 Fax 0541/956341  
 47842 S. GIOVANNI IN M. (RN)  
 e-mail: mtma@mtmarchetti.com  
 http://www.mtmarchetti.com

PRODUZIONE MODULI ROTANTI

PAGINA HAS150-3-10

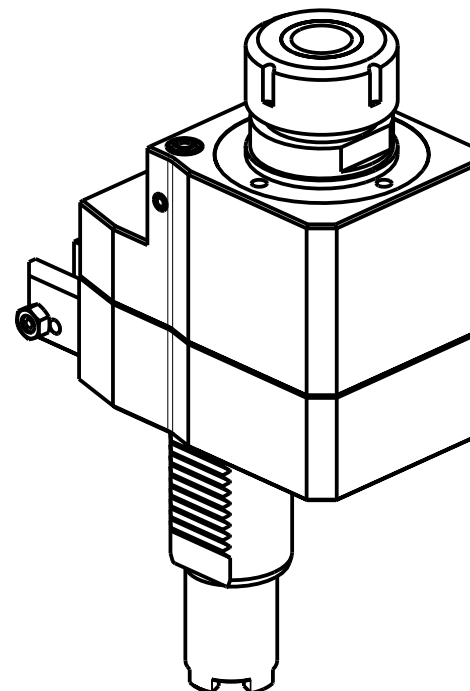
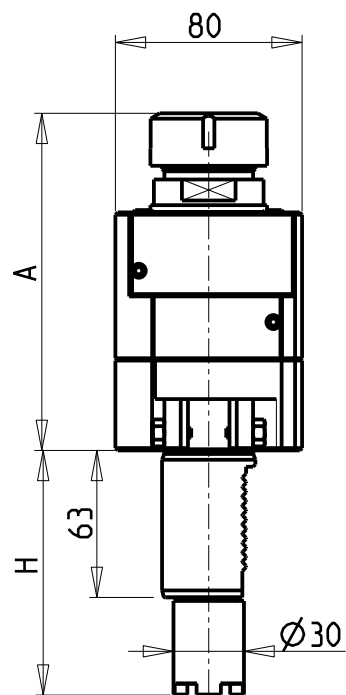
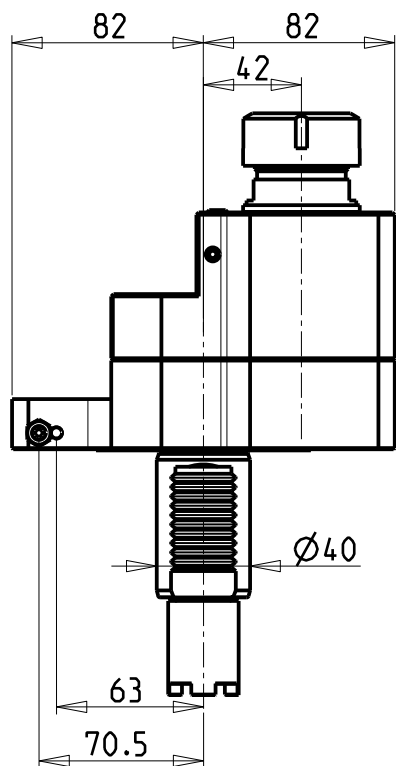

Cod. MT	Mandrino Spindle Spindel	I	RPM	Coppia Max Max Torque Max Drehmoment	Lubrificazione int. Coolant through Innenkuhlung	Lubrificazione est. Ext. coolant Ausseinkuhlung	A	H	Tipo Torretta Turret Type Revolver Typ	CHIAVI NON INCLUSE Keys not included Schlüssel nicht einbegriffen	
HAS0080032	ER32	1:1	6000	70Nm		X	144.66	117.55	VDI STANDARD / HYBRID TURRET	CHUB41	CHSTER32
HAS0081132	ER32	1:1	6000	70Nm	P=30bar		164.96	117.55	VDI STANDARD / HYBRID TURRET	CHUB38	CHSTER32
HAS0082132	ER32	2:1	3000	100Nm		X	144.66	117.55	VDI STANDARD / HYBRID TURRET	CHUB41	CHSTER32
HAS0084232	ER32	2:1	3000	100Nm	P=30bar		164.96	117.55	VDI STANDARD / HYBRID TURRET	CHUB38	CHSTER32

HAAS

MOD: ST10/20/30 - DS30 - TL15/25

MODULO MOTORIZZATO ASSIALE DISASSATO 42mm VDI40

Axial driven tool re-directed by 42mm VDI40

Axial angetriebenes Werkzeug achsversetzt um 42mm VDI40

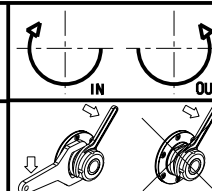

**M.T. srl**

Via Casino Albini 480  
Tel. 0541/956034-957884

Fax 0541/956341

47842 S. GIOVANNI IN M. (RN)

e-mail: mtma@mtmarchetti.com

http://www.mtmarchetti.com

PRODUZIONE MODULI ROTANTI



PAGINA HAS160-3-00

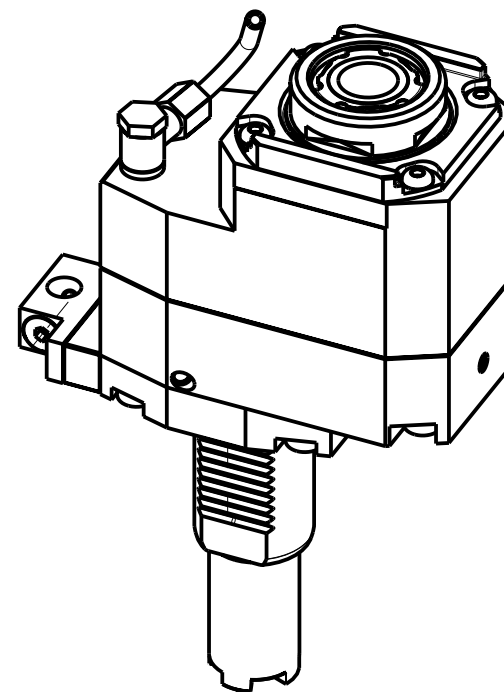
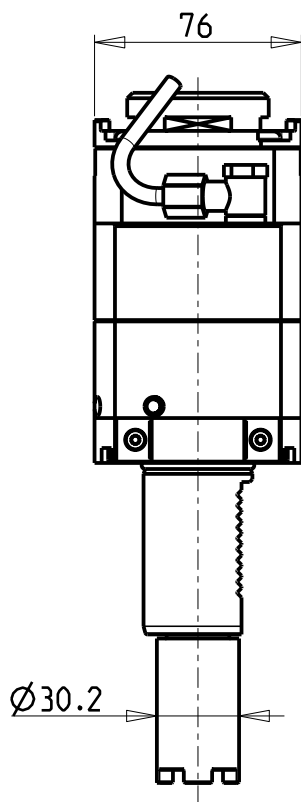
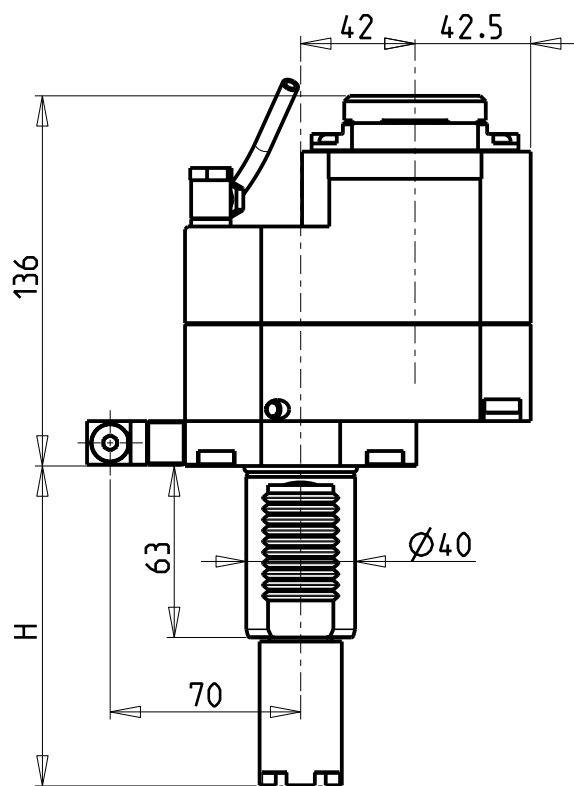

- Chiave inclusa
- Key included
- Schlüssel inbegriffen

Cod. MT	Mandrino Spindle Spindel	I	RPM	Coppia Max Max Torque Max Drehmoment	Lubrificazione int. Coolant through Innenkühlung	Lubrificazione est. Ext. coolant Aussenkühlung	H	Tipo Torretta Turret Type Revolver Typ	CHIAVI NON INCLUSE Keys not included Schlüssel nicht einbegriffen		
HAS0317132	ERA32	1:2	12000	45Nm	-	X	117.55	VDI STANDARD / HYBRID TURRET	CHUB30	CHTAER32ZC	OKU0650004
HAS0317232	ERA32	1:2	12000	45Nm	P=30bar	X	117.55	VDI STANDARD / HYBRID TURRET	CHUB30	CHTAER32ZC	OKU0650004

HAAS

MOD: ST10/20/30 - DS30 - TL15/25

MODULO MOTORIZZATO ASSIALE MOLTIPLICATO I=1:2 DISASSATO 42mm VDI40

Axial geared-up I=1:2 driven tool re-directed by 42mm VDI40

Axial angetriebenes Werkzeug uebersetzt I=1:2 achsversetzt um 42mm VDI40

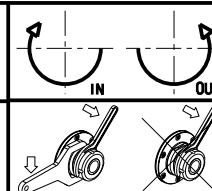

**M.T. srl**

Via Casino Albini 480  
Tel. 0541/956034-957884  
Fax 0541/956341

47842 S. GIOVANNI IN M. (RN)  
e-mail: mtma@mtmarchetti.com  
http://www.mtmarchetti.com

PRODUZIONE MODULI ROTANTI



PAGINA HAS160-3-20



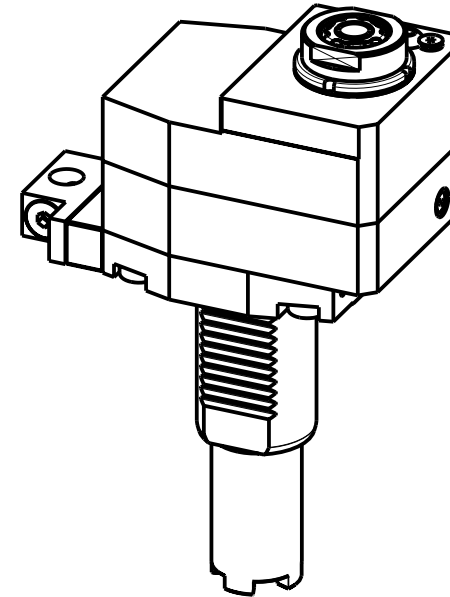
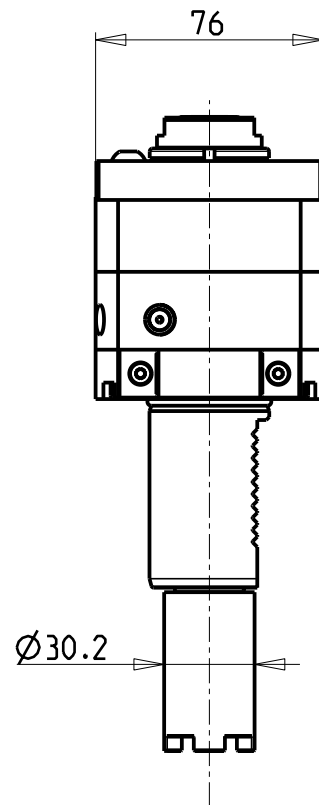
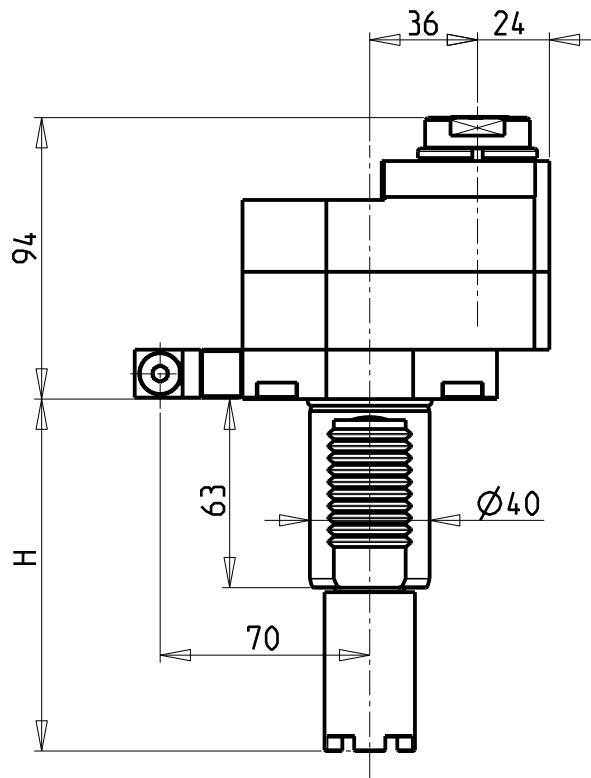

- Chiave inclusa
- Key included
- Schlüssel inbegriffen

Cod. MT	Mandrino Spindle Spindel	I	RPM	Coppia Max Max Torque Max Drehmoment	Lubrificazione int. Coolant through Innenkühlung	Lubrificazione est. Ext. coolant Aussenkühlung	H	Tipo Torretta Turret Type Revolver Typ	CHIAVI NON INCLUSE Keys not included Schlüssel nicht einbegriffen			
									CHUB30	CHUB19_SP3	CHTAER16ZC	
HAS0380116	ERA16	1:3	18000	10Nm	-	X	117.55	VDI STANDARD / HYBRID TURRET	CHUB30	CHUB19_SP3	CHTAER16ZC	NEW
HAS0380216	ERA16	1:3	18000	10Nm	P=30bar	X	117.55	VDI STANDARD / HYBRID TURRET	CHUB30	CHUB19_SP3	CHTAER16ZC	NEW

HAAS  
 MOD: ST10/20/30 - DS30 - TL15/25  
 MODULO MOTORIZZATO ASSIALE MOLTIPLICATO I=1:3 DISASSATO 36mm VDI40  
 Axial geared-up I=1:3 driven tool re-directed by 36mm VDI40  
 Axial angetriebenes Werkzeug uebersetzt I=1:3 achsversetzt um 36mm VDI40

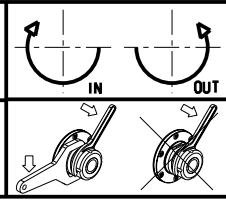

**M.T. srl**  
 Via Casino Albini 480  
 Tel. 0541/956034-957884  
 Fax 0541/956341  
 47842 S. GIOVANNI IN M. (RN)  
 e-mail: mtma@mtmarchetti.com  
 http://www.mtmarchetti.com

PRODUZIONE MODULI ROTANTI

PAGINA HAS160-3-30

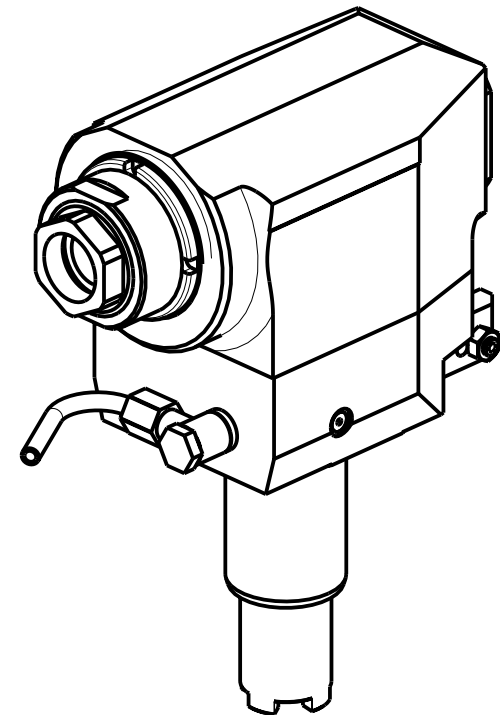
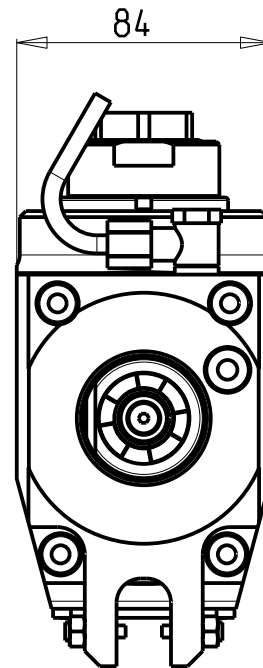
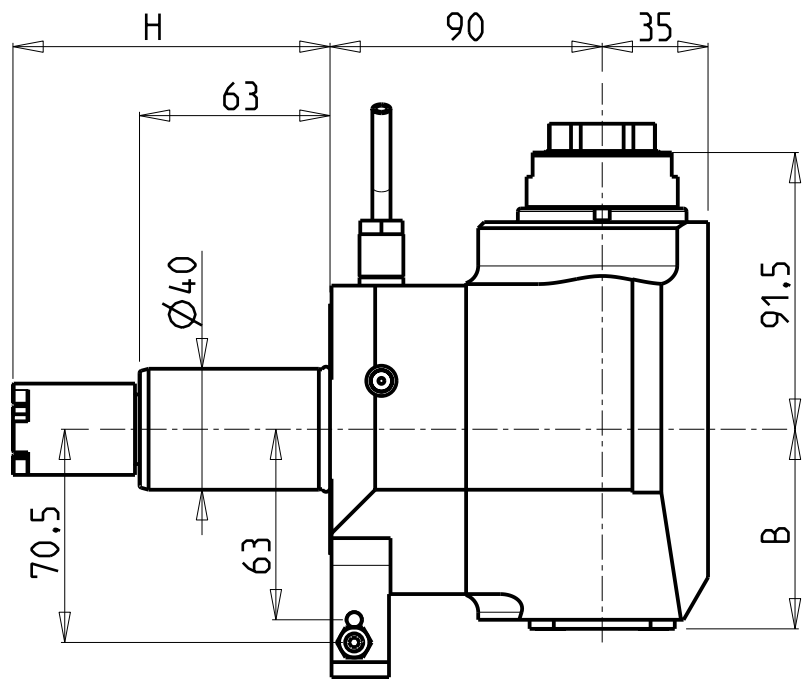

Cod. MT	Mandrino Spindle Spindel	I	RPM	Coppia Max Max Torque Max Drehmoment	Lubrificazione int. Coolant through Innenkühlung	Lubrificazione est. Ext. coolant Aussenkühlung	B	H	Tipo Torretta Turret type Revolver typ	CHIAVI NON INCLUSE Keys not included Schlüssel nicht einbegriffen	
HAS0160132	ERA32	1:2	12000	30Nm		X	66	117.55	VDI STANDARD / HYBRID TURRET	CHUB41	CHUB32
HAS0160232	ERA32	1:2	12000	30Nm	P=70bar	X	76	117.55	VDI STANDARD / HYBRID TURRET	CHUB41	CHUB32

HAAS

MOD: ST10/20/30 - DS30 - TL15/25

MODULO MOTORIZZATO RADIALE MOLTIPLICATO I=1:2 VDI40

Radial geared-up I=1:2 driven tool VDI40

Radial angetriebenes Werkzeug uebersetzt I=1:2 VDI40

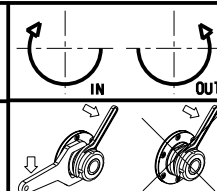

**M.T. srl**

Via Casino Albini 480  
Tel. 0541/956034-957884

Fax 0541/956341

47842 S. GIOVANNI IN M. (RN)

e-mail: mtma@mtmarchetti.com

http://www.mtmarchetti.com

PRODUZIONE MODULI ROTANTI



PAGINA HAS203-3-10

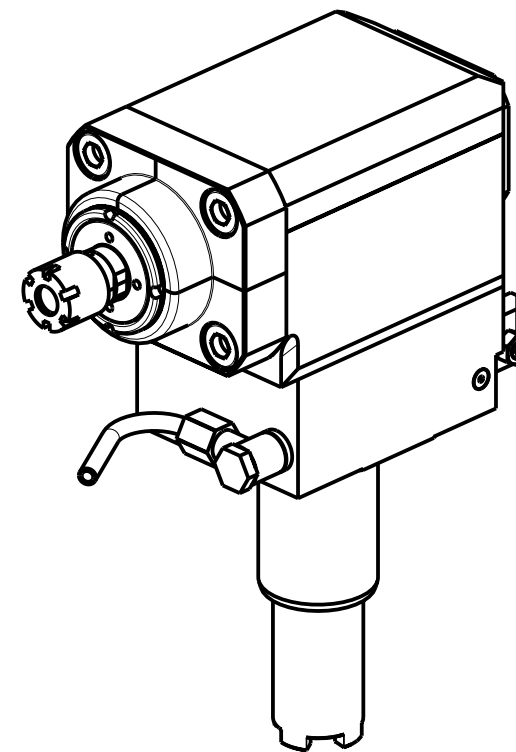
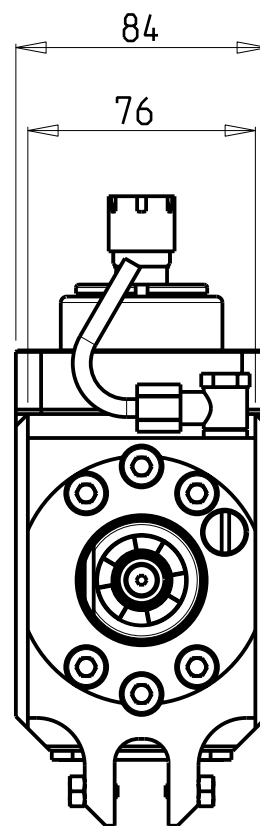
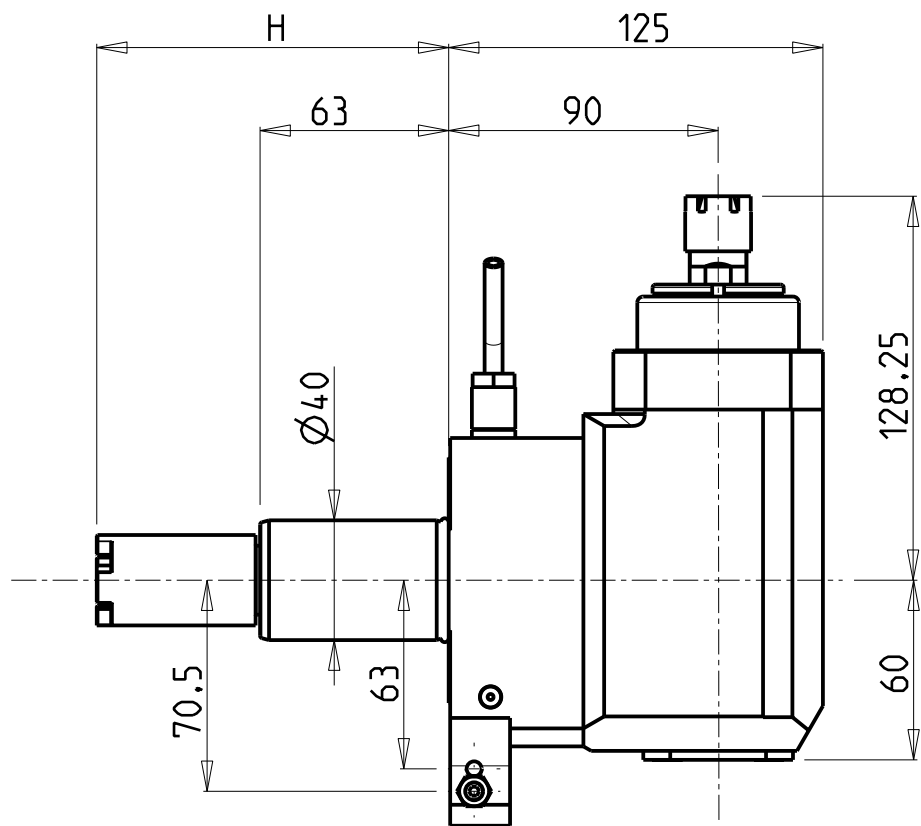

Cod. MT	Mandrino Spindle Spindel	I	RPM	Coppia Max Max Torque Max Drehmoment	Lubrificazione est. Ext. coolant Aussenkühlung	H	Tipo Torretta Turret type Revolver typ	CHIAVI INCLUSE Keys included Schlüssel einbegriffen	
HAS0340016	ER16	1:3	18000	10Nm	X	117.55	VDI STANDARD / HYBRID TURRET	CHUB17	CHMNER16

HAAS

MOD: ST10/20/30 - DS30 - TL15/25

MODULO MOTORIZZATO RADIALE MOLTIPLICATO I=1:3 VDI40

Radial geared-up I=1:3 driven tool VDI40

Radial angetriebenes Werkzeug uebersezt I=1:3 VDI40

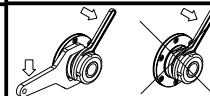

**M.T. srl**

Via Casino Albini 480  
Tel. 0541/956034-957884  
Fax 0541/956341

47842 S. GIOVANNI IN M. (RN)  
e-mail: mtma@mtmarchetti.com  
http://www.mtmarchetti.com

PRODUZIONE MODULI ROTANTI



PAGINA HAS208-3-10

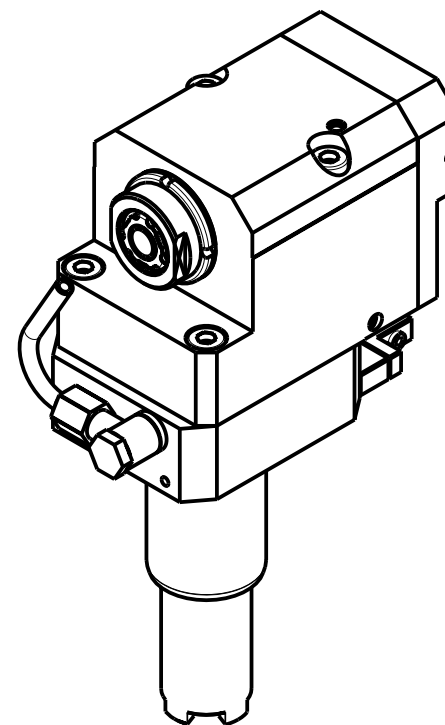
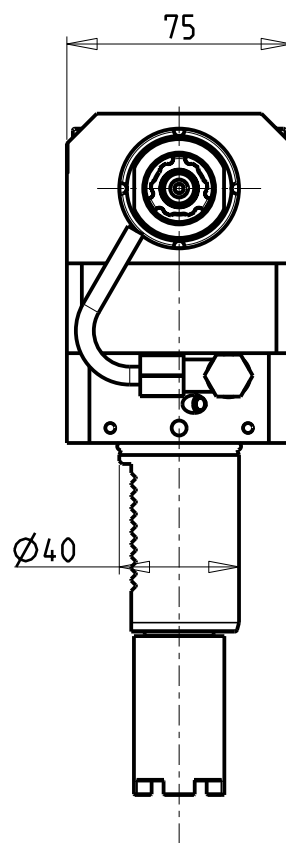
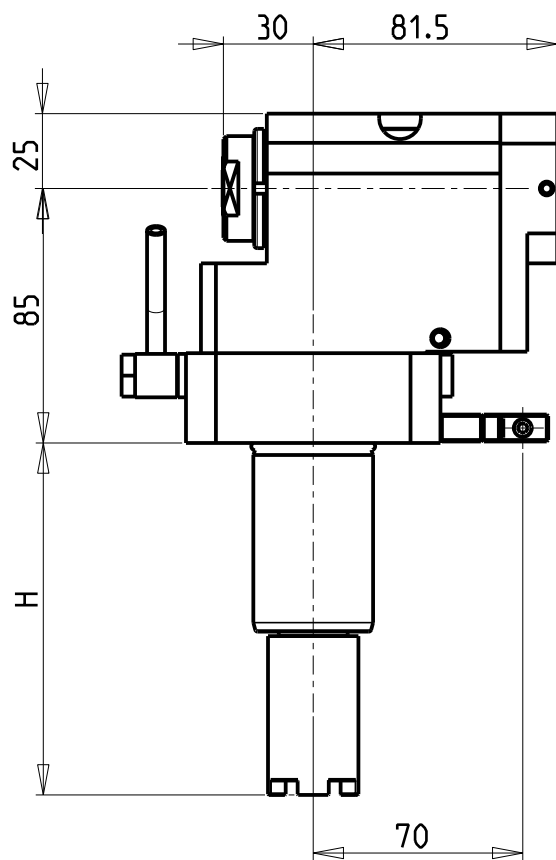

- Chiave inclusa
- Key included
- Schluessel inbegriffen

Cod. MT	Mandrino Spindle Spindel	I	RPM	Coppia Max Max Torque Max Drehmoment	Lubrificazione int. Coolant through Innenkühlung	Lubrificazione est. Ext. coolant Aussenkühlung	H	Tipo Torretta Turret Type Revolver Typ	CHIAVI NON INCLUSE Keys not included Schluessel nicht einbegriffen			
HAS04.10116	ERA16	1:3	18000	10Nm	-	X	117.55	VDI STANDARD / HYBRID TURRET	CHUB30	CHUB19_SP3	CHTAER16ZC	NEW
HAS04.10216	ERA16	1:3	18000	10Nm	P=70bar	X	117.55	VDI STANDARD / HYBRID TURRET	CHUB30	CHUB19_SP3	CHTAER16ZC	NEW

HAAS

MOD: ST10/20/30 - DS30 - TL15/25

MODULO MOTORIZZATO RADIALE ARRETRATO MOLTIPLICATO I=1:3 VDI40

Radial geared-up I=1:3 rear-set driven tool VDI40

Radial angetriebenes Werkzeug uebersetzt I=1:3 zurueckversetzt VDI40

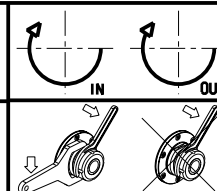

**M.T. srl**

Via Casino Albini 480  
Tel. 0541/956034-957884

Fax 0541/956341

47842 S. GIOVANNI IN M. (RN)

e-mail: mtma@mtmarchetti.com

http://www.mtmarchetti.com

PRODUZIONE MODULI ROTANTI



PAGINA HAS226-3-10

**ATTENZIONE - ATTENTION - ACHTUNG**

- VERIFICARE LE MISURE DI INGOMBRO PER POSSIBILE INTERFERENZA SU ALCUNI MODELLI DI MACCHINE
- Please check the overall sizes for possible interferences on some machine models
- Bitte überprüfen sie das ausmass um mögliche interferenzen auf einigen maschinen modellen zu vermeiden

**ATTENZIONE - ATTENTION - ACHTUNG**

- Per lo smontaggio degli utensili utilizzare sempre la chiave di contrasto come indicato nel manuale d'uso.
- For disassembly of the tools use always the contrast key as mentioned in the user instructions.
- Fuer das Abmontieren der Werkzeuge immer den Gegenschlüssel benutzen wie in der Bedienungsanleitung erwäehnt.

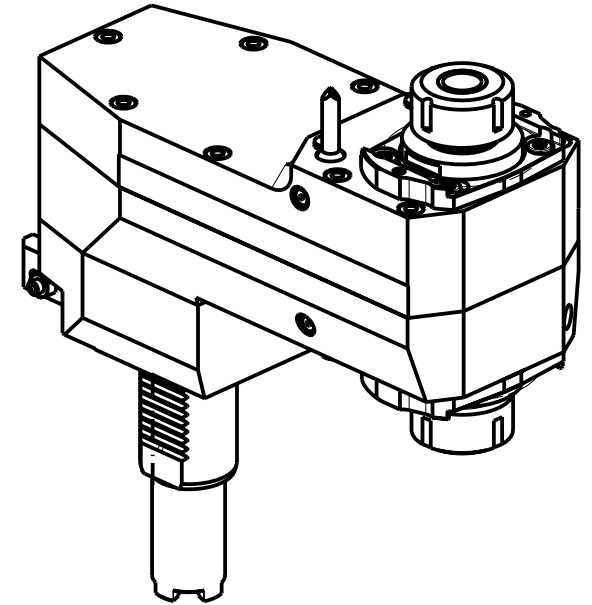
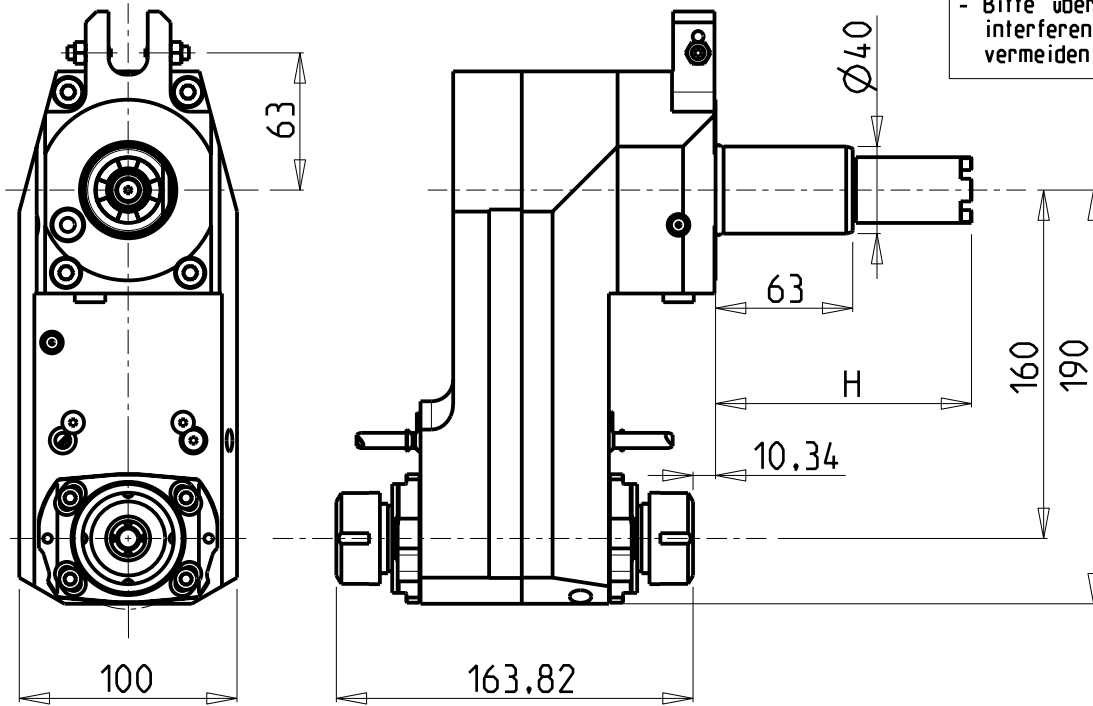

Cod. MT	Mandrino Spindle Spindel	I	RPM	Coppia Max Max Torque Max Drehmoment	Lubrificazione est. Ext. coolant Ausseukuehlung	H	Tipo Torretta Turret type Revolver typ	CHIAVI NON INCLUSE Keys not included Schluessel nicht einbegriffen
HAS0230225	ER25+ER25	1:1	6000	70Nm	X	117.55	VDI STANDARD / HYBRID TURRET	OKU0650004 • CHSTER25

• Chiave inclusa
• Key included
• Schluessel inbegriffen

HAAS  
 MOD: ST10/20/30 - DS30  
 MODULO MOTORIZZATO ASSIALE BISPORGENTE DISASSATO 160mm VDI40  
 Axial rear-set opposite face twin driven tool re-directed by 160mm VDI40  
 Axial angetriebenes Werkzeug halb vospringend achsversetzt um 160mm VDI40

**M.T. srl**  
 Via Casino Albini 480  
 Tel. 0541/956034-957884  
 Fax 0541/956341  
 47842 S. GIOVANNI IN M. (RN)  
 e-mail: mtma@mtmarchetti.com  
 http://www.mtmarchetti.com

PRODUZIONE MODULI ROTANTI



PAGINA HAS243-3-10

### ATTENZIONE - ATTENTION - ACHTUNG

- Per lo smontaggio degli utensili utilizzare sempre la chiave di contrasto come indicato nel manuale d'uso.
- For disassembly of the tools use always the contrast key as mentioned in the user instructions.
- Fuer das Abmontieren der Werkzeuge immer den Gegenschlüssel benutzen wie in der Bedienungsanleitung erwahnt.

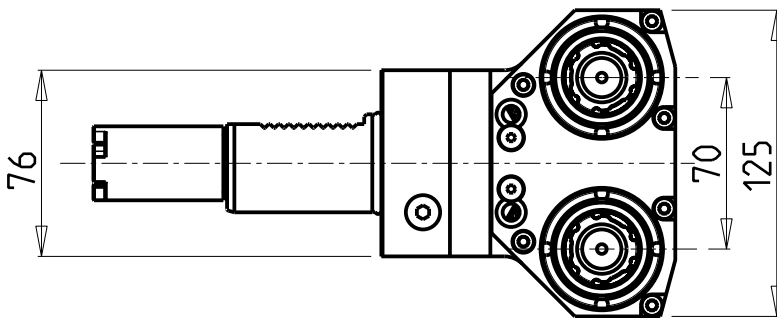
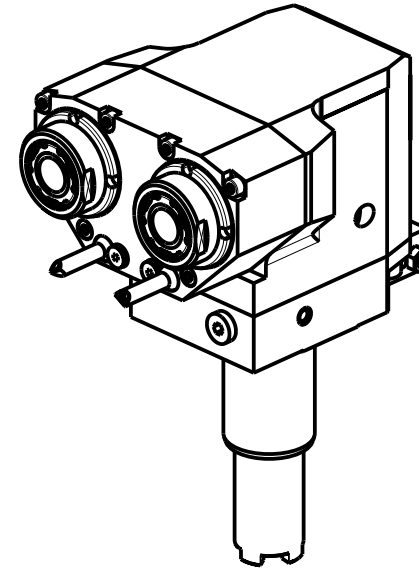
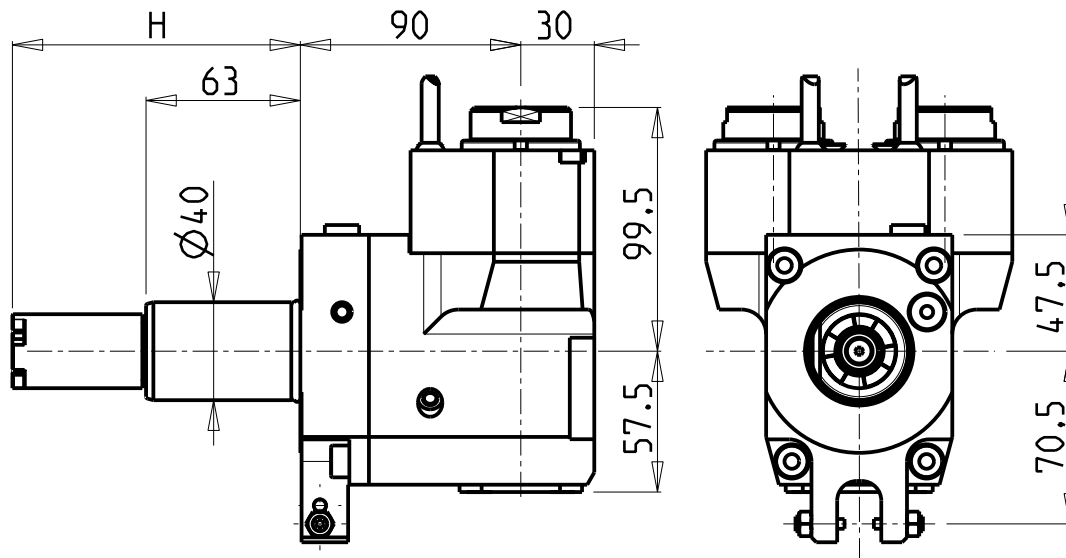

- Chiave inclusa
- Key included
- Schlüssel inbegriffen

Cod. MT	Mandrino Spindle Spindel	I	RPM	Coppia Max Max Torque Max Drehmoment	N°Utensili N° Tools N° Werkzeuge	Lubrificazione int. Coolant through Innenkuehlung	Lubr.esterna Ext. coolant Aussenkuehlung	H	Tipo Torretta Turret type Revolver typ	CHIAVI NON INCLUSE Keys not included Schluessel nicht einbegriffen		
HAS0240125	ERA25	1:1	6000	50Nm	2		X	117.55	VDI STANDARD / HYBRID TURRET	CHUB38	CHUB27	CHTAER25ZC •
HAS0240225	ERA25	1:1	6000	50Nm	2	P=70bar	X	117.55	VDI STANDARD / HYBRID TURRET	CHUB38	CHUB27	CHTAER25ZC •

HAAS

MOD: ST10/20/30 - DS30

MODULO MOTORIZZATO RADIALE 2 USCITE IN Y VDI40

Radial single side twin head driven tool in Y VDI40

Radial angetriebenes Werkzeug 2 Ausgaenge in Y VDI40

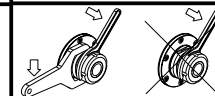
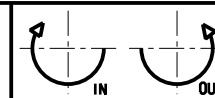

**M.T. srl**

Via Casino Albini 480  
Tel. 0541/956034-957884

Fax 0541/956341

47842 S. GIOVANNI IN M. (RN)

e-mail: mtma@mtmarchetti.com

http://www.mtmarchetti.com

PRODUZIONE MODULI ROTANTI



PAGINA HAS263-3-10

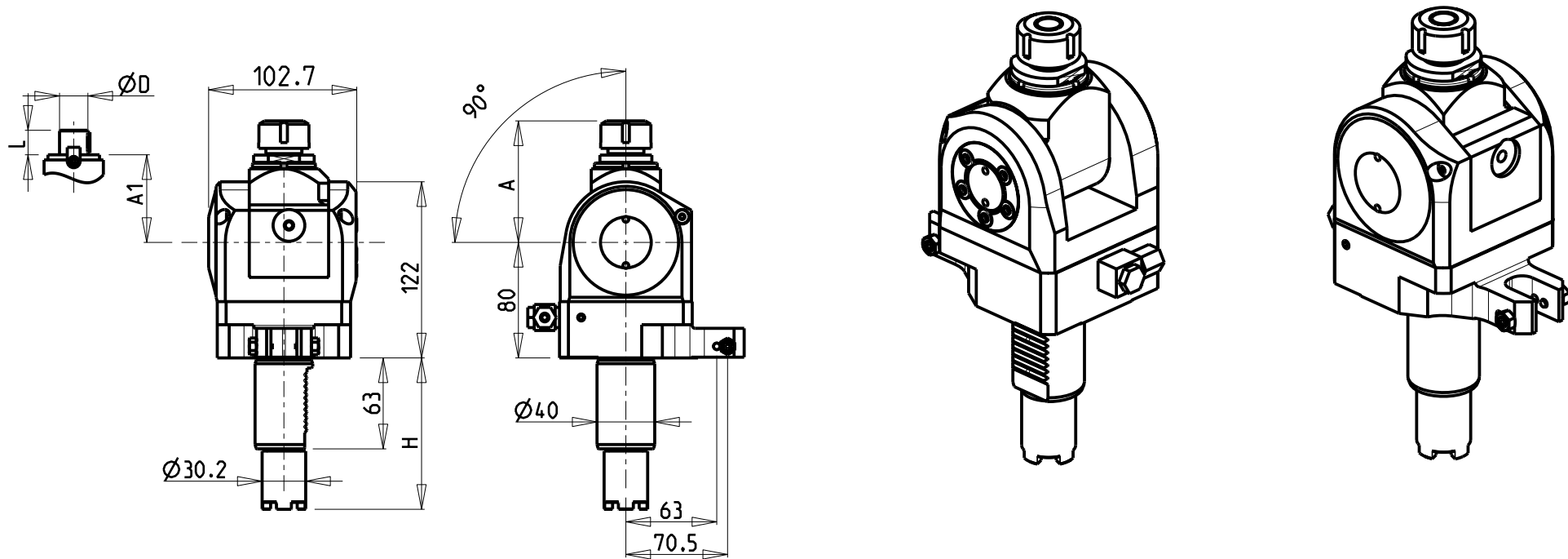

Cod. MT	Mandrino Spindle Spindel	I	RPM	Coppia Max Max Torque Max Drehmoment	Lubrificazione est. Ext. coolant Aussenkuehlung	A	A1	D	L	H	Tipo Torretta Turret Type Revolver Typ	CHIAVI INCLUSE Keys included Schluessel inbegriffen	
HAS0060020	ER20	1:1	6000	40Nm	X	84.16	-	-	-	117.55	VDI STANDARD / HYBRID TURRET	CHUB36	CHSTER20
HAS0060025	ER25	1:1	6000	40Nm	X	85.66	-	-	-	117.55	VDI STANDARD / HYBRID TURRET	CHUB36	CHSTER25
HAS0061617	Ø16x17	1:1	6000	40Nm	X	-	65	16	17	117.55	VDI STANDARD / HYBRID TURRET	CHUB36	CH_VTCROCE_M08
HAS0062219	Ø22x19	1:1	6000	40Nm	X	-	66	22	22	117.55	VDI STANDARD / HYBRID TURRET	CHUB36	CH_VTCROCE_M10
HAS0061905	Ø3/4"x3/4"	1:1	6000	40Nm	X	-	65	3/4"	3/4"	117.55	VDI STANDARD / HYBRID TURRET	CHUB36	CH_VTCROCE_M08

HAAS

MOD: ST10/20/30 - DS30 - TL15/25

MODULO MOTORIZZATO ORIENTABILE 0-90° VDI40

0-90° adjustable angle driven tool VDI40

Angetriebenes Werkzeug schwenkbar 0-90° VDI40

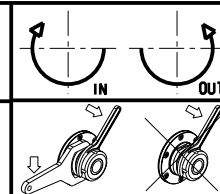

**M.T. srl**

Via Casino Albini 480  
Tel. 0541/956034-957884

Fax 0541/956341

47842 S. GIOVANNI IN M. (RN)

e-mail: mtma@mtmarchetti.com

http://www.mtmarchetti.com

PRODUZIONE MODULI ROTANTI



PAGINA HAS330-3-00

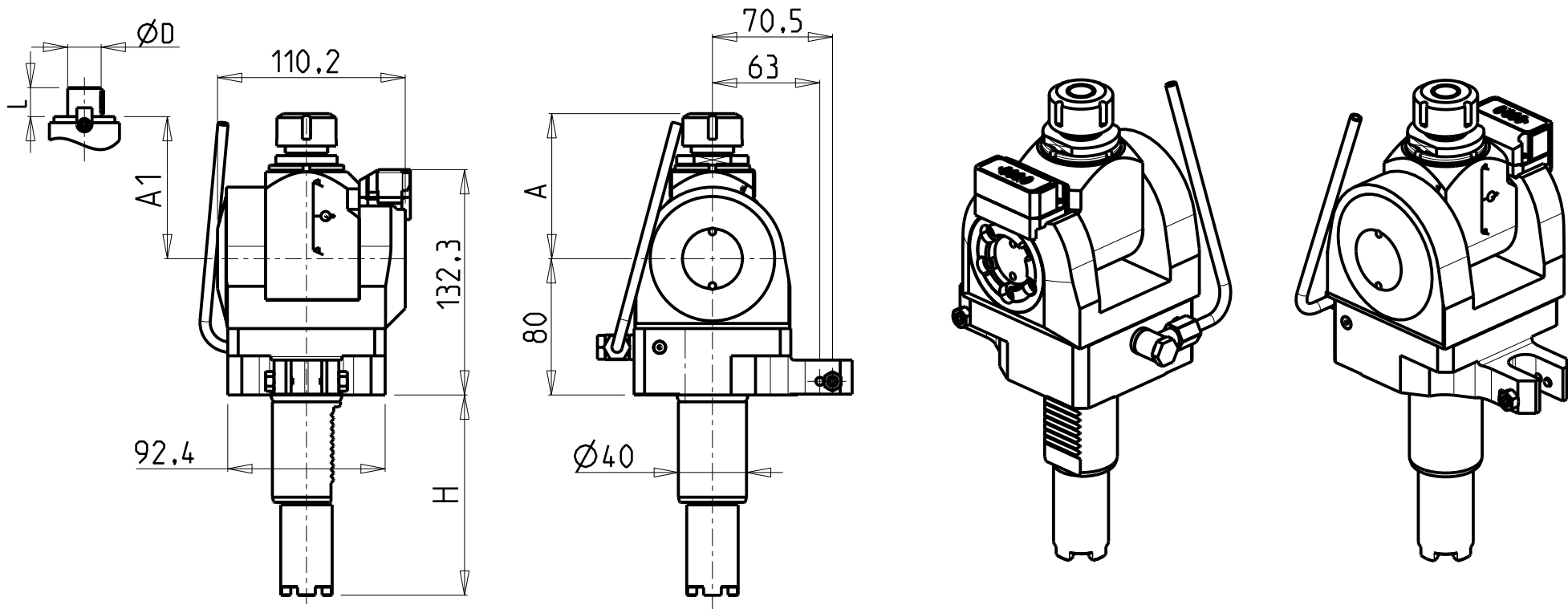

Cod. MT	Mandrino Spindle Spindel	I	RPM	Coppia Max Max Torque Max Drehmoment	Lubrificazione est. Ext. coolant Ausseukuehlung	A	A1	D	L	H	Tipo Torretta Turret Type Revolver Typ	CHIAVI INCLUSE Keys included Schluessel inbegriffen		
HAS0450120	ER20	1:1	6000	40Nm	X	85.16	-	-	-	117.55	VDI STANDARD	CHUB36	CHSTER20	NEW
HAS0450125	ER25	1:1	6000	40Nm	X	86.16	-	-	-	117.55	VDI STANDARD	CHUB36	CHSTER25	NEW
HAS0450516	Ø16x17	1:1	6000	40Nm	X	-	65	16	17	117.55	VDI STANDARD	CHUB36	CH_VTCROCE_M08	NEW
HAS0450522	Ø22x19	1:1	6000	40Nm	X	-	66	22	19	117.55	VDI STANDARD	CHUB36	CH_VTCROCE_M10	NEW
HAS0450519	Ø3/4"x3/4"	1:1	6000	40Nm	X	-	65	3/4"	3/4"	117.55	VDI STANDARD	CHUB36	CH_VTCROCE_M08	NEW

HAAS

MOD: ST10/20/30 - DS30 - TL15/25

MODULO MOTORIZZATO ORIENTABILE ±90° CON NONIO DIGITALE VDI40  
 ±90° adjustable angle driven tool with digital display VDI40  
 Angetriebenes Werkzeug schwenkbar ±90° mit digital display VDI40

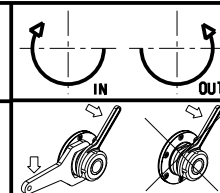

**M.T. srl**

Via Casino Albini 480  
 Tel. 0541/956034-957884  
 Fax 0541/956341

47842 S. GIOVANNI IN M. (RN)  
 e-mail: mtma@mtmarchetti.com  
 http://www.mtmarchetti.com

PRODUZIONE MODULI ROTANTI



PAGINA HAS333-3-01



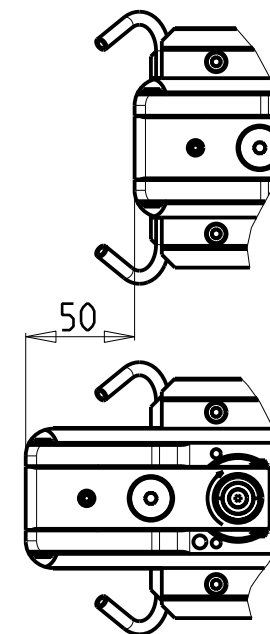
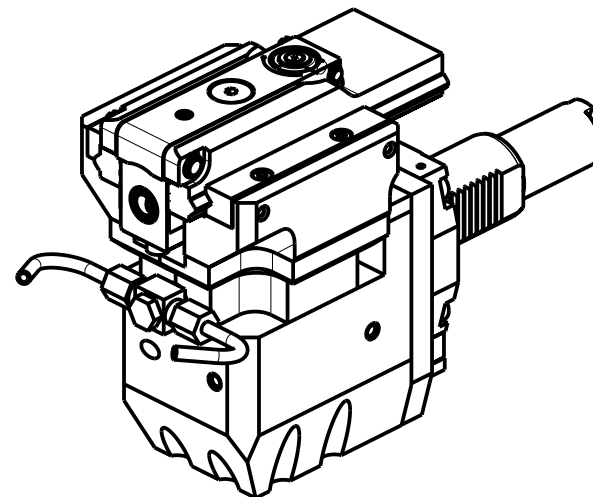
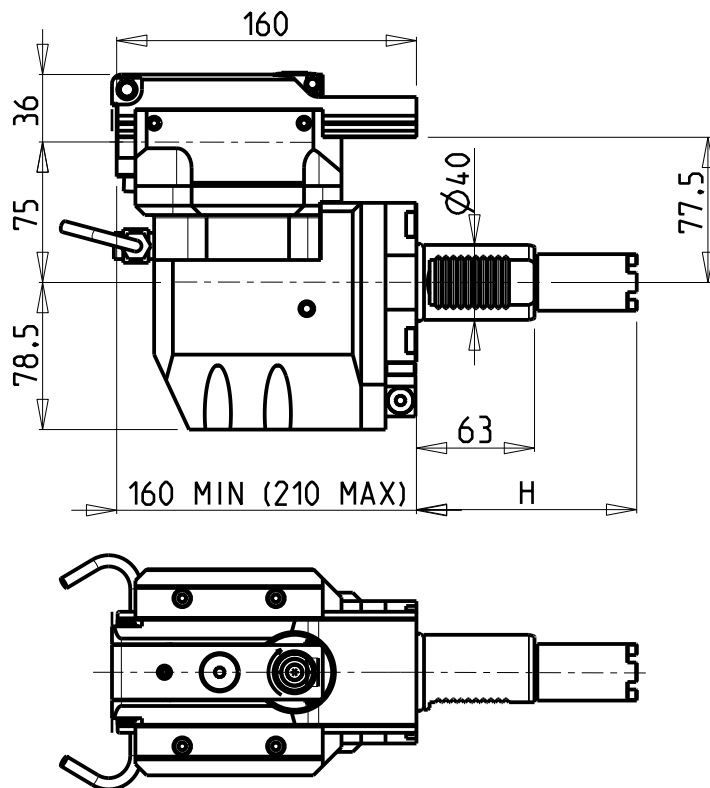
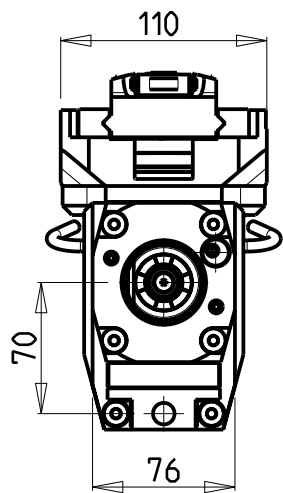

PER UTENSILI STOZZATORI VEDI PAG. TBL400-1-00  
 FOR DRIVEN SLOTTING TOOL CUTTING-TOOLS SEE PAGE TBL400-1-00  
 FÜR NUTENSTOSS-WERKZEUG SCHNEIDWERKZEUGE SIEHE SEITE TBL400-1-00

Cod. MT	I	RPM MAX	Lubr. esterna Ext. coolant Aussenkuehlung	H	Tipo Torretta Turret type Revolver typ
HAS0350100	4:1	2000	X	117.55	VDI STANDARD / HYBRID TURRET

NEW

HAAS

MOD: ST10/20/30 - DS30 - TL15/25

MODULO MOTORIZZATO STOZZATORE CORSA 50mm VDI40

Slotting driven tool 50mm stroke VDI40

Keilnutenstossmaschine 50mm Hub VDI40

**M.T. srl**

Via Casino Albini 480  
 Tel. 0541/956034-957884  
 Fax 0541/956341  
 47842 S. GIOVANNI IN M. (RN)  
 e-mail: mtma@mtmarchetti.com  
 http://www.mtmarchetti.com

PRODUZIONE MODULI ROTANTI



PAGINA HAS360-3-30

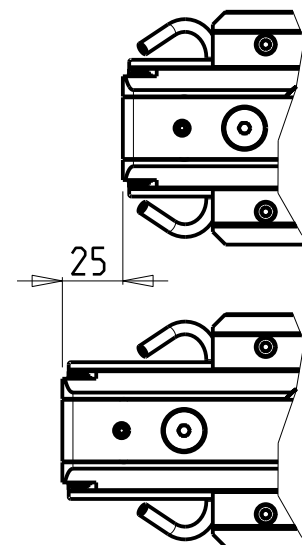
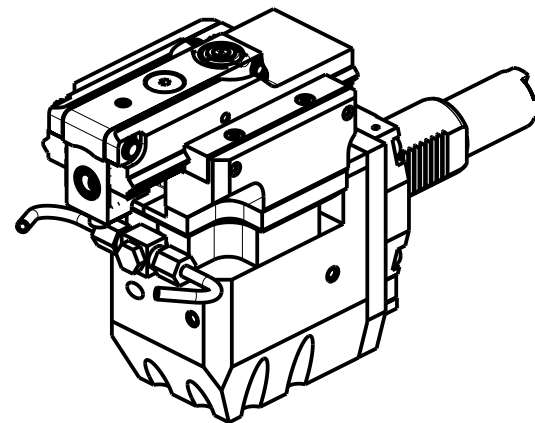
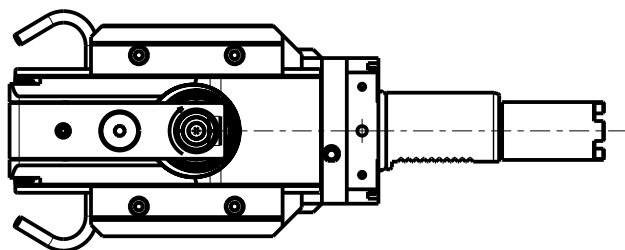
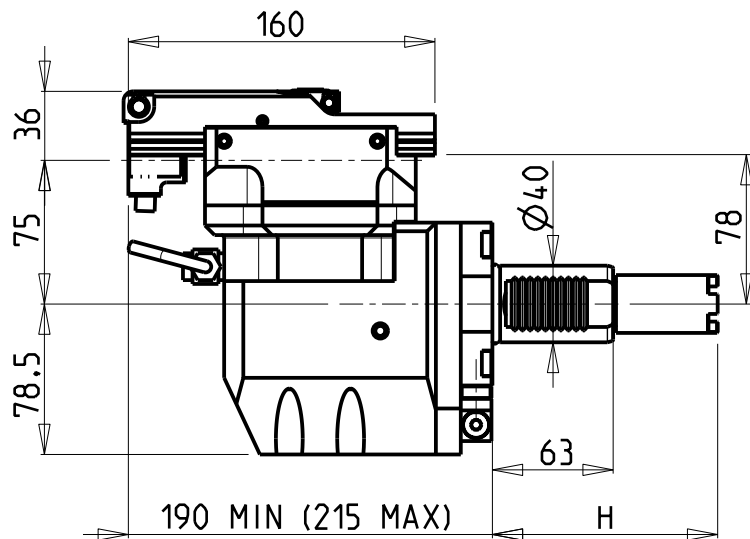
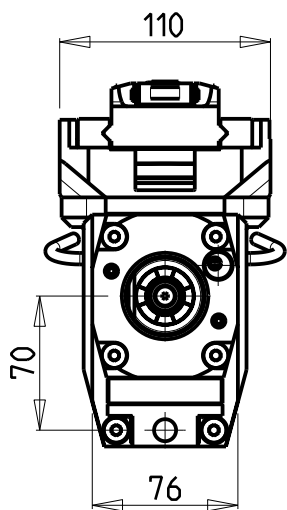

PER UTENSILI STOZZATORI VEDI PAG. TBL400-1-00  
 FOR DRIVEN SLOTTING TOOL CUTTING-TOOLS SEE PAGE TBL400-1-00  
 FÜR NUTENSTOSS-WERKZEUG SCHNEIDWERKZEUGE SIEHE SEITE TBL400-1-00

Cod. MT	I	RPM MAX	Lubr. esterna Ext. coolant Aussenkuehlung	H	Tipo Torretta Turret type Revolver typ
HAS0350200	4:1	2400	X	117.55	VDI STANDARD / HYBRID TURRET NEW

HAAS

MOD: ST10/20/30 - DS30 - TL15/25

MODULO MOTORIZZATO STOZZATORE CORSA 25mm VDI40

Slotting driven tool 25mm stroke VDI40

Keilnutenstossmaschine 25mm Hub VDI40

**M.T. srl**

Via Casino Albini 480  
 Tel. 0541/956034-957884  
 Fax 0541/956341  
 47842 S. GIOVANNI IN M. (RN)  
 e-mail: mtma@mtmarchetti.com  
 http://www.mtmarchetti.com

PRODUZIONE MODULI ROTANTI



PAGINA HAS360-3-31